

EARLY PERUVIAN PEASANTS:
THE CULTURE HISTORY OF
A CENTRAL HIGHLANDS VALLEY

A thesis presented

by

David Ludvig Browman

to

The Department of Anthropology

in partial fulfillment of the requirements

for the degree of

Doctor of Philosophy

in the subject of

Anthropology

Harvard University
Cambridge, Massachusetts

June, 1970

List of Tables and Charts

| | | |
|-----------|--|---------|
| Chart 1. | Tentative correlations of cultural periods | 44 |
| Table 1. | Mode example: Cochachongos enclosed bowl 2 | 46 |
| Table 2. | Olla modes | 47 |
| Table 3. | Enclosed bowl modes | 48 |
| Table 4. | Open bowl modes | 49 |
| Table 5. | Jar modes | 50 |
| Table 6. | Vessel form seriation | 51-56 |
| Table 7. | PJUM radiocarbon sample series | 287 |
| Table 8. | Ceramic period dates by laboratory method | 288-289 |
| Table 9. | Lithic unit dating | 290 |
| Table 10. | Early Horizon units | 291 |
| Table 11. | Early Intermediate Period units | 292 |
| Table 12. | Middle Horizon units | 293 |

List of Maps

- Map 1 Physiographic map of survey area
- Map 2 Modern day settlement pattern
- Map 3 Distribution of the 300 sites (PJuM 501-800)
- Map 4 Pirwapuquio period sites
- Map 5 Cochachongos period sites
- Map 6 Uchupas period sites
- Map 7 Usupuquio period sites
- Map 8 Huacrapuquio period sites
- Map 9 Calpish period sites
- Map 10 Quinsahuanca period sites
- Map 11 Matapuquio and Arhuaturo period sites, combined
- Map 12 Inca period sites
- Map 13 Sites with Viques mitmaquna ware
- Map 14 Distribution of the Late Intermediate Period and the
Late Horizon storage colca sites

Figures

1. PJuM 613: Profile of North wall
2. PJuM 502: Profile of North walls of cuts 10, 15, 16, 17 and 18
3. PJuM 614-10: Profile of pithouse section
4. PJuM 613: Plan of semi-subterranean housepits
5. PJuM 677, Tomb 7: Profile of tomb cross-section
6. PJuM 625-10: Plan of multi-chambered tomb
7. Comparison of Middle Horizon temple plans (PJuM 501, 618, 648)
8. PJuM 618-1E: Profile of wall section of a temple structure
9. PJuM 525-10: Section of a square dwelling with rounded corners
10. PJuM 536: Circular storage colca
11. PJuM 576: Rectangular storage colca
12. Jurpac points
13. Tinyari lithic tools
14. Early Horizon points
15. Early Intermediate Period and early Middle Horizon points
16. Cochachongos graver and bifaces
17. Cochachongos scrapers
18. Cochachongos core bifaces
19. Cochachongos core scraper planes
20. Cochachongos spearthrower handle piece
21. Cochachongos bone implements
22. Cochachongos bone implements
23. Ucupuquic lithic (bifaces, graver, scrapers)

- 24a. Type 1 Digging Weights: Cochachongos and Usupuquio
- 24b. Type 2 Digging Weights: Usupuquio through Inca
25. Calpish bone implements
26. Calpish adzes and miscellaneous
27. Calpish metal objects
28. Arhuaturo bone implements
29. Blade Type 1: Matapuquio through Inca
30. Blade Type 2: Matapuquio through Inca
31. Hoe Types 1 and 2: Calpish, Quinsahuanca, Matapuquio
32. Hoe Types 3 and 4: Arhuaturo, Arhuaturo-Inca
33. Inca maces and painted pebbles
34. Pirwapuquio ollas
35. Pirwapuquio enclosed bowls
36. Pirwapuquio open bowls
37. Pirwapuquio jars
38. Pirwapuquio ladles, lids, bottle spouts
39. Pirwapuquio A
40. Pirwapuquio A
41. Pirwapuquio BC
42. Pirwapuquio DEF
43. Cochachongos enclosed bowls
44. Cochachongos open bowls
45. Cochachongos jars
46. Cochachongos jars
47. Cochachongos bottles, ollas, lids, ceramic beads

48. Cochachongos geometrics and conical ceramic tops
49. Cochachongos AB
50. Cochachongos AB
51. Cochachongos AB
52. Cochachongos AB
53. Cochachongos ABC figurines
54. Cochachongos C (PJUM 613 offering deposit)
55. Cochachongos C
56. Cochachongos C
57. Cochachongos C
58. Cochachongos C
59. Cochachongos C
60. Cochachongos CD negative
61. Cochachongos D
62. Cochachongos D
63. Cochachongos handles, lugs, bases
64. Cochachongos D
65. Cochachongos D
66. Cochachongos D
67. Cochachongos D
68. Cochachongos D
69. Cochachongos E
70. Cochachongos E
71. Cochachongos E figurines
72. Uchupas open bowls
73. Uchupas jars and enclosed bowls

74. Uchupas AB
75. Uchupas C
76. Uchupas C
77. Usupuquio open bowls
78. Usupuquio jars
79. Usupuquio jars, enclosed bowls, lid
80. Usupuquio AB
81. Usupuquio AB
82. Usupuquio C
83. Usupuquio C
84. Usupuquio D (Tomb 7, PJuM 677-2)
85. Usupuquio D (Tomb 7, PJuM 677-2)
86. Usupuquio D
87. Usupuquio D
88. Usupuquio CDE llama figurines
89. Usupuquio D
90. Usupuquio D figurines
91. Usupuquio E
92. Usupuquio E
93. Usupuquio E figurines
94. Huacrapuquio side spout, enclosed bowls, ollas, lid
95. Huacrapuquio open bowls
96. Huacrapuquio jars
97. Huacrapuquio A--Usupuquio ware
98. Huacrapuquio A--Huacrapuquio ware

99. Huacrapuquio AB
100. Huacrapuquio B
101. Huacrapuquio C--Huacawato orange ware
102. Huacrapuquio C--Huacrapuquio ware
103. Huacrapuquio C--Huacrapuquio ware
104. Huacrapuquio C
105. Huacrapuquio C
106. Huacrapuquio C figurines
107. Huacrapuquio C figurines
108. Calpish ollas
109. Calpish enclosed bowls
110. Calpish open bowls
111. Calpish jars
112. Calpish jars
113. Calpish jars
114. Calpish AB trade sherds
115. Calpish AB trade sherds
116. Calpish B, BC trade sherds
117. Calpish AB, B--trade sherds and local copy
118. Calpish A, AB jar lugs
119. Calpish B, C face jar lugs
120. Calpish A, AB legs, bases, lugs
121. Calpish B, C legs, bases, lugs
122. Calpish jar neck appliques
123. Calpish A

124. Calpish A
125. Calpish AB
126. Calpish AB
127. Calpish AB
128. Modeled Calpish face features
129. Calpish AB (Wariwilka modeled face neck jar)
130. Calpish AB, B (Wariwilka mold-made face neck jar)
131. Calpish B (PJuM 625-10-1, Burial 4; Calpish PJuM 618)
132. Calpish B mold-made face neck jars
133. Calpish B
134. Calpish B
135. Calpish B
136. Calpish C
137. Quinsahuanca enclosed bowls, ollas
138. Quinsahuanca open bowls
139. Quinsahuanca jars
140. Quinsahuanca jars
141. Quinsahuanca A jar lugs
142. Quinsahuanca B jar lugs
143. Quinsahuanca jar neck decoration
144. Quinsahuanca A
145. Quinsahuanca A
146. Quinsahuanca A
147. Quinsahuanca B
148. Quinsahuanca B

149. Matapuquio ollas, enclosed bowls, lid
150. Matapuquio open bowls
151. Matapuquio jars
152. Matapuquio jars
153. Matapuquio (Burial 1, PJuM 502-16-2)
154. Matapuquio jar neck decoration
155. Matapuquio
156. Matapuquio
157. Arhuaturo ollas, enclosed bowls
158. Arhuaturo jars
159. Arhuaturo jars
160. Arhuaturo open bowls
161. Arhuaturo
162. Arhuaturo
163. Arhuaturo
164. Arhuaturo
165. Arhuaturo faces, Types 1 and 2
166. Arhuaturo faces, Types 2 and 3
167. Arhuaturo faces, Type 3, and ears
168. Arhuaturo appliques
169. Arhuaturo-Inca faces, Types 4, 5 and 6
170. Arhuaturo-Inca faces, Types 7, 8, 9 and 10
171. Arhuaturo/Arhuaturo-Inca/Viques faces
172. Arhuaturo-Inca ears and abstract appliques
173. Arhuaturo-Inca animal heads

174. Arhuaturo-Inca ollas and enclosed bowls
175. Arhuaturo-Inca jars
176. Arhuaturo-Inca jars
177. Arhuaturo-Inca jars
178. Arhuaturo-Inca jars
179. Arhuaturo-Inca open bowls
180. Arhuaturo-Inca
181. Arhuaturo-Inca
182. Arhuaturo-Inca
183. Arhuaturo-Inca
184. Inca: Chimu-Pachacamac blackware, local Inca miniature ware, bottles
185. Inca Ware 1 bowls, plates
186. Inca Ware 1 rimmed bowls
187. Inca Ware 1 jars
188. Inca Ware 2 open bowls, enclosed bowls
189. Inca Ware 2 rimmed bowls
190. Inca Ware 2 jars
191. Inca Ware 1 jar lugs
192. Inca Ware 2 jar lugs
193. Inca: lids, pedestal bases, plate handles
194. Inca Ware 1 typical motifs
195. Inca Ware 2 typical motifs
196. Typical Inca aryballoids, both wares
197. Viques open bowls
198. Viques jars

199. Viques faces, appliques
200. Viques
201. Viques
202. Viques
203. Viques
204. Viques
205. Viques
206. Llaqsa ollas, enclosed bowls, open bowls
207. Llaqsa jars
208. Llaqsa jars, pedestal base, faces
209. Llaqsa
210. Ocopa ollas, low-rimmed ollas
211. Ocopa open bowls
212. Ocopa jars
213. Ocopa ring-based, open bowls
214. Ocopa
215. Retama enclosed bowls, open bowls, jars
216. Retama ollas, low-rimmed ollas
217. Retama
218. Modern ollas
219. Modern ollas, enclosed bowl
220. Modern jars
221. Modern

Explanation of color code for figures

Single designate

R = red
O = orange
Y = yellow
C = cream
W = white
P = pink
T = tan
N = natural ware base
Gy = grey
Br = brown
Bl = black (sometimes indicated by shading)
Pur = purple

Multiple designate

C.W. = cream-white
W.W. = white white, a Viques pigment, in contrast to Arhuaturo CW
B.B. = brownish black
Lt. R. = light red, a Calpish pigment
Dk. R. = dark red, a Calpish pigment
M.R. = Mantaro red, an Arhuaturo pigment, slightly red-orange
I.R. = Inca red, an Inca pigment, more scarlet to purple red
V.R. or L.R. = Viques red, a mitmaquna pigment, light red
R.R. = rust red, a post-Hispanic conquest pigment
N.O.T. = natural orange tan ware base

Hyphenated terms

read as composites; that is, R-O = red-orange, etc

For simplicity sake, all design pigments have been indicated only by letter instead of complex shading. Orientation of the sherds is always so that the interior is to the left of the rim profile and the exterior is to the right.

Provenience of illustrated decorated sherds

| | | | |
|---------|---------------------------|---------|-------------------------|
| Fig. 39 | PJuM 704 | Fig. 70 | PJuM 613 a, f |
| Fig. 40 | PJuM 704 | | PJuM 707 b, c, g |
| Fig. 41 | PJuM 685 b-f, h-k | | PJuM 709 d, h |
| | PJuM 686 a, g | Fig. 71 | PJuM 613 a |
| Fig. 42 | PJuM 739 a, b, h-k | | PJuM 707 c, e |
| | PJuM 777 c, d, f, g | | PJuM 709 b, d |
| | PJuM 791 e | Fig. 74 | PJuM 613 a, c, d, p |
| Fig. 49 | PJuM 613 b-e | | PJuM 625 h-j |
| | PJuM 614 a | | PJuM 704 k-o |
| | PJuM 625 f | | PJuM 707 b, e-g |
| Fig. 50 | PJuM 613 c, e | Fig. 75 | PJuM 635 l |
| | PJuM 625 d, f-h | | PJuM 789 a-k |
| | PJuM 684 a, b | Fig. 76 | PJuM 635 d, f-h, k-m, q |
| Fig. 52 | PJuM 613 c-e, g | | PJuM 666 n-p, r |
| | PJuM 614 a, b, f | | PJuM 701 a-c, e, i, j |
| Fig. 53 | PJuM 613 b | Fig. 80 | PJuM 574 a |
| | PJuM 614 d | | PJuM 598 g, l, n |
| | PJuM 682 c | | PJuM 661 k |
| | PJuM 684 a | | PJuM 675 h-j |
| Fig. 55 | PJuM 613 d-l | | PJuM 750 b, c |
| | PJuM 614 a | | PJuM 756 m |
| | PJuM 682 c | | PJuM 775 d-f |
| | PJuM 683 b | Fig. 81 | PJuM 769 |
| Fig. 56 | PJuM 613 b | Fig. 82 | PJuM 720 a, b, d, e |
| | PJuM 614 a | | PJuM 738 h, i |
| Fig. 57 | PJuM 613 d, e | | PJuM 778 c, f, g, j |
| | PJuM 683 a-c | | PJuM 790 k |
| Fig. 58 | PJuM 613 | Fig. 83 | PJuM 594 d, h, j |
| Fig. 59 | PJuM 613 a, b, e, f, h, i | | PJuM 738 g, i, k |
| | PJuM 683 c, d, g | | PJuM 778 a, b, f |
| Fig. 60 | PJuM 613 b-f | | PJuM 790 c, e |
| | PJuM 683 a | Fig. 86 | PJuM 507 d-h |
| Fig. 61 | PJuM 613 | | PJuM 614 a, b |
| Fig. 62 | PJuM 613 a-c, f-q | | PJuM 616 i |
| | PJuM 709 e, d | Fig. 87 | PJuM 507 f |
| Fig. 64 | PJuM 613 | | PJuM 616 h |
| Fig. 65 | PJuM 613 | | PJuM 677 a-e |
| Fig. 66 | PJuM 613 | | PJuM 791 g |
| Fig. 67 | PJuM 613 | Fig. 88 | PJuM 507 b |
| Fig. 68 | PJuM 613 | | PJuM 677 e |
| Fig. 69 | PJuM 613 b-o | | PJuM 738 c |
| | PJuM 707 a | | PJuM 789 a |
| | | | PJuM 791 d |

| | | | |
|----------|---|-----------|--|
| Fig. 91 | PJuM 625 a-c PJuM 635 d, e, h PJuM 794 f, g | Fig. 125 | PJuM 618 |
| Fig. 92 | PJuM 625 c PJuM 635 b PJuM 664 g PJuM 678 a PJuM 744 d, e PJuM 789 h, i | Fig. 126 | PJuM 501 d-j PJuM 618 a-c, k, l |
| Fig. 97 | PJuM 603 b-d PJuM 665 a PJuM 701 g, h PJuM 734 e, f | Fig. 127. | PJuM 501 a, b PJuM 618 c, e, g, h PJuM 625 d, f, i |
| Fig. 98 | PJuM 603 b PJuM 655 c PJuM 701 d-f | Fig. 129 | PJuM 501 |
| Fig. 100 | PJuM 711 g, k PJuM 720 h PJuM 787 i, j PJuM 789 a-f | Fig. 130 | PJuM 501 |
| Fig. 101 | PJuM 764 | Fig. 131 | PJuM 617 b PJuM 625 a |
| Fig. 102 | PJuM 666 b PJuM 721 a PJuM 764 c, e, i, j PJuM 775 d, f, g, h | Fig. 133 | PJuM 502 p PJuM 615 b PJuM 618 c PJuM 669 i, j PJuM 676 l PJuM 681 m, n PJuM 683 a PJuM 688 h PJuM 701 d, e, g, o PJuM 767 f, k |
| Fig. 103 | PJuM 698 c, i PJuM 721 f PJuM 764 b, d, e, g, h PJuM 775 a | Fig. 134 | PJuM 502 g-j PJuM 669 d PJuM 676 e PJuM 681 f PJuM 688 b, c PJuM 699 a PJuM 782 k |
| Fig. 104 | PJuM 764 c-f PJuM 771 a, b | Fig. 135 | PJuM 502 d PJuM 676 a, f, g PJuM 681 b PJuM 688 e PJuM 782 k |
| Fig. 114 | PJuM 501 a, b, e, f, i-k PJuM 618 c, g PJuM 620 d PJuM 625 h | Fig. 136 | PJuM 689 a PJuM 698 c, d, j PJuM 724 h PJuM 753 b, e, g, i PJuM 792 f |
| Fig. 115 | PJuM 501 a, b, g-j PJuM 618 c-f | Fig. 144 | PJuM 708 e-g PJuM 787 a-d |
| Fig. 116 | PJuM 501 b PJuM 617 f PJuM 681 d PJuM 688 g, h PJuM 701 c PJuM 753 a PJuM 767 e | Fig. 145 | PJuM 575 e PJuM 708 a-d, f, g |
| Fig. 117 | PJuM 501 a, b PJuM 618 c | Fig. 146 | PJuM 708 b-d PJuM 787 a, e |
| Fig. 123 | PJuM 620 | Fig. 147 | PJuM 531 a-c PJuM 532 g, k, l PJuM 540 h, m PJuM 548 c, d PJuM 578 f, i, j |
| Fig. 124 | PJuM 620 | | |

| | | | |
|----------|--|----------|--|
| Fig. 148 | PJuM 532 e,f PJuM 548 a PJuM 564 b,c PJuM 578 f,i,j | Fig. 200 | PJuM 698 h,j PJuM 700 d,i PJuM 701 e,k PJuM 704 c PJuM 709 a PJuM 727 g PJuM 768 b,f |
| Fig. 155 | PJuM 514 a-c PJuM 516 i PJuM 525 d PJuM 532 f,j,k PJuM 565 a PJuM 569 h PJuM 655 e | Fig. 201 | PJuM 700 h-k PJuM 701 g,l,m PJuM 702 e,f PJuM 711 a-c PJuM 771 d |
| Fig. 156 | PJuM 514 d PJuM 516 e PJuM 525 b PJuM 532 a PJuM 554 c | Fig. 202 | PJuM 666 a PJuM 701 e,f PJuM 702 c,d PJuM 768 b |
| Fig. 161 | PJuM 502 a-f,h,j,k PJuM 726 g PJuM 751 i | Fig. 203 | PJuM 625 f PJuM 630 c PJuM 701 a,b PJuM 768 d,e |
| Fig. 162 | PJuM 502 a,b,i PJuM 530 c PJuM 532 j PJuM 627 h PJuM 629 d-f | Fig. 204 | PJuM 701 e PJuM 702 c,f PJuM 711 b,d PJuM 775 a |
| Fig. 163 | PJuM 502 a PJuM 564 b PJuM 629 d-f | | |
| Fig. 164 | PJuM 502 a,d PJuM 627 e PJuM 629 b,c | | |
| Fig. 180 | PJuM 522 a,b,h PJuM 571 n PJuM 602 g,i PJuM 630 d,e PJuM 639 f PJuM 666 c PJuM 715 j PJuM 722 m PJuM 740 l | | |
| Fig. 181 | PJuM 502 a PJuM 623 b PJuM 740 c | | |
| Fig. 182 | PJuM 502 f PJuM 602 d,e PJuM 701 c,h PJuM 715 a,b,g | | |

| | | Jauja-Huancayo | Southern Sierra | Northern Sierra | Coastal Peru |
|---------------------------------|---------|------------------------------------|--------------------------------------|-------------------------------|---------------------------|
| Terminal Preceramic | 2000 BC | Tinyari | Cachi | Lauricocha III | Gaviota |
| | 1800 BC | | | | |
| Initial Period | 1600 BC | | | | |
| | 1400 BC | | | | |
| | 1200 BC | | | | |
| Early Horizon | 1000 BC | Pirwapuquio | Marcavalle | Kotosh-- levels DEF/4 | Curayacu CD |
| | 800 BC | | Wichqana | | |
| | 600 BC | Cochachongos | Atalla Chanapata | Kotosh-- levels EC/23 | |
| | 400 BC | | Rancha | Chavin--Mosna and San Blas | Los Patos |
| | 200 BC | | Chupas | San Blas | Ocucaje 8-10 |
| Early Intermediate Period | 0 AD/BC | Uchupas | Wimpilley | Huaylas | Topara (Chongos) |
| | AD 200 | Usupuquio | Caja | | Miramar |
| | AD 400 | Huacrapuquio | Huarpa Chakipampa | Huamachuco | Nieveria |
| Middle Horizon | AD 600 | Calpish | Ocros Viñaque | Cajamarca III | Pachacamac AB (Atarco) |
| | AD 800 | Quinsahuanca | (Huarpa II) Coras Pillpintuyoq | | |
| | AD 1000 | | | | |
| Late Intermediate Period | AD 1200 | Matapuquio | Arjalla | | |
| | | Arhuaturo | Patarjay | | |
| Late Horizon | AD 1400 | Arhuaturo-Inca Viques Llaqsa | Inca (Angara) | (Chimu?) | Pachacamac-Inca |
| Colonial | AD 1600 | Ocopa | | | |
| Republican | AD 1800 | Retama | | | |
| | AD 2000 | Modern | | | |

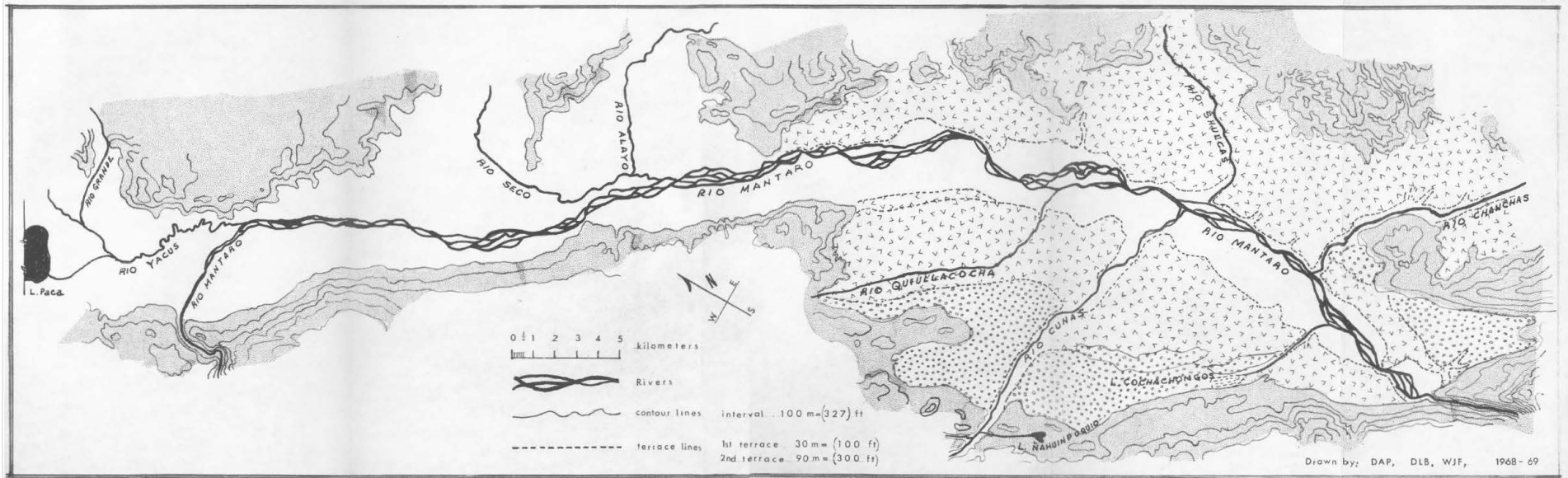

0 1 2 3 4 5 kilometers

Rivers

contour lines interval .100 m (327) ft

terrace lines 1st terrace 30 m (100 ft)
2nd terrace 90 m (300 ft)

Drawn by: DAP, DLB, WJF, 1968-69

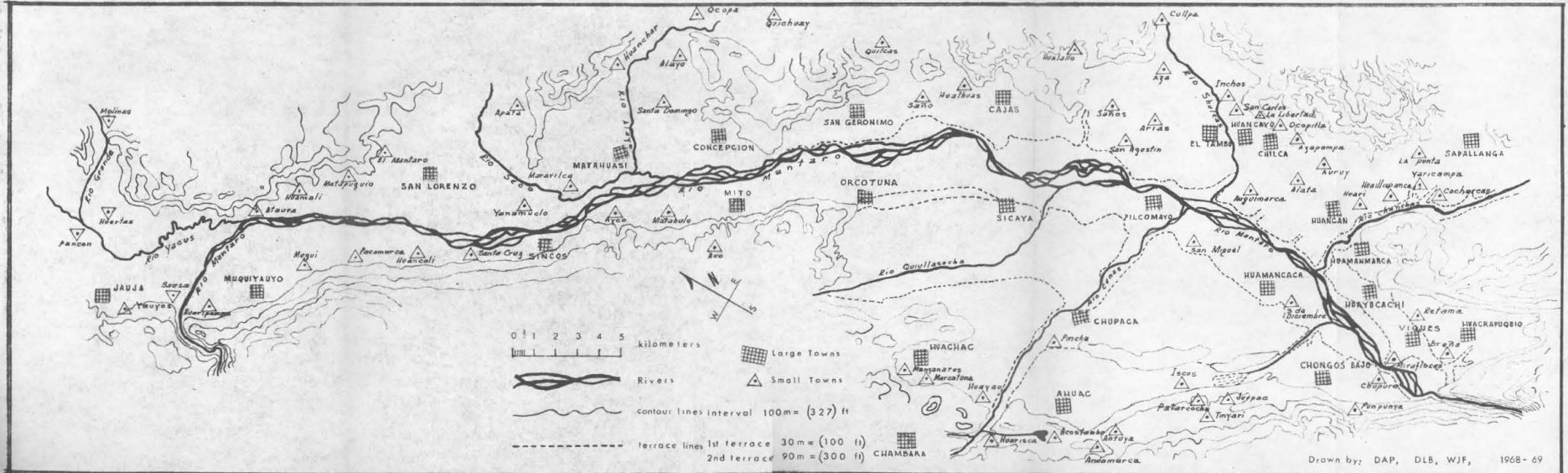

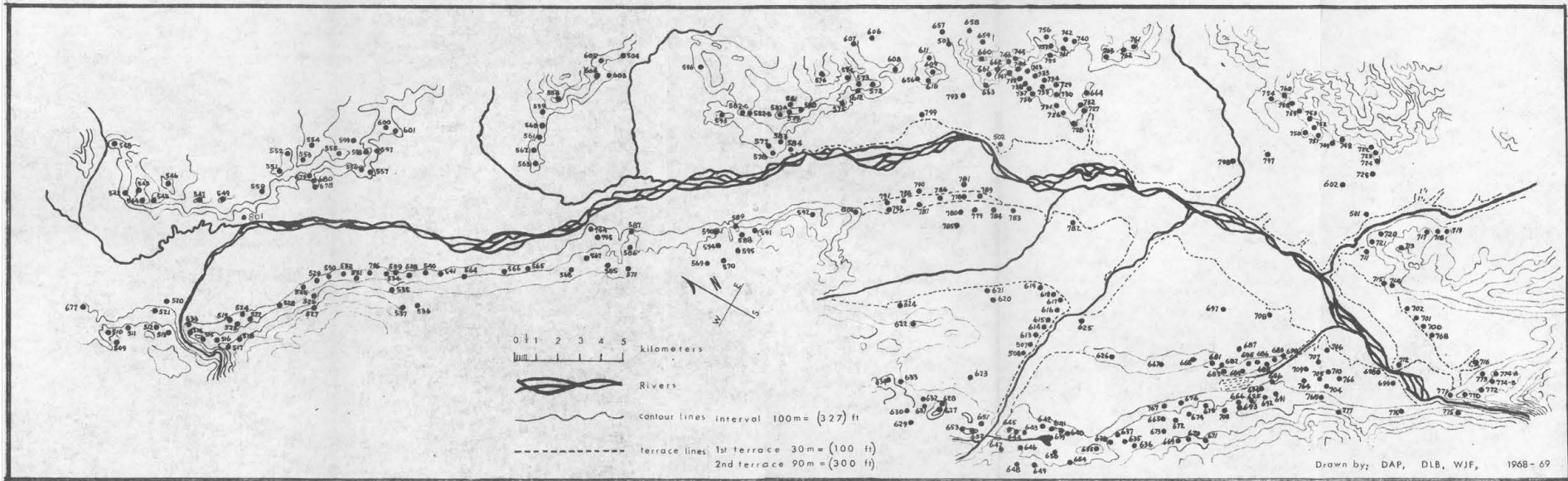

Drawn by: DAP, DLB, WJF, 1968-69

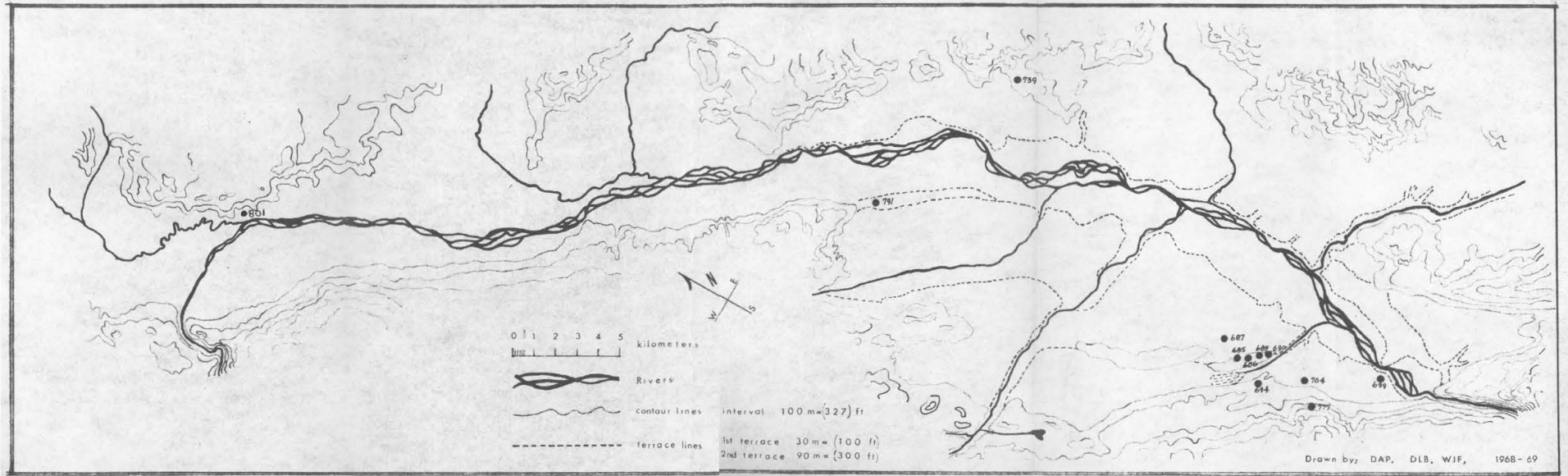

0 1 2 3 4 5 kilometers

Rivers

contour lines interval 100 m (327 ft)

terrace lines 1st terrace 30 m (100 ft)
2nd terrace 90 m (300 ft)

Drawn by: DAP, DLB, WIF, 1968-69

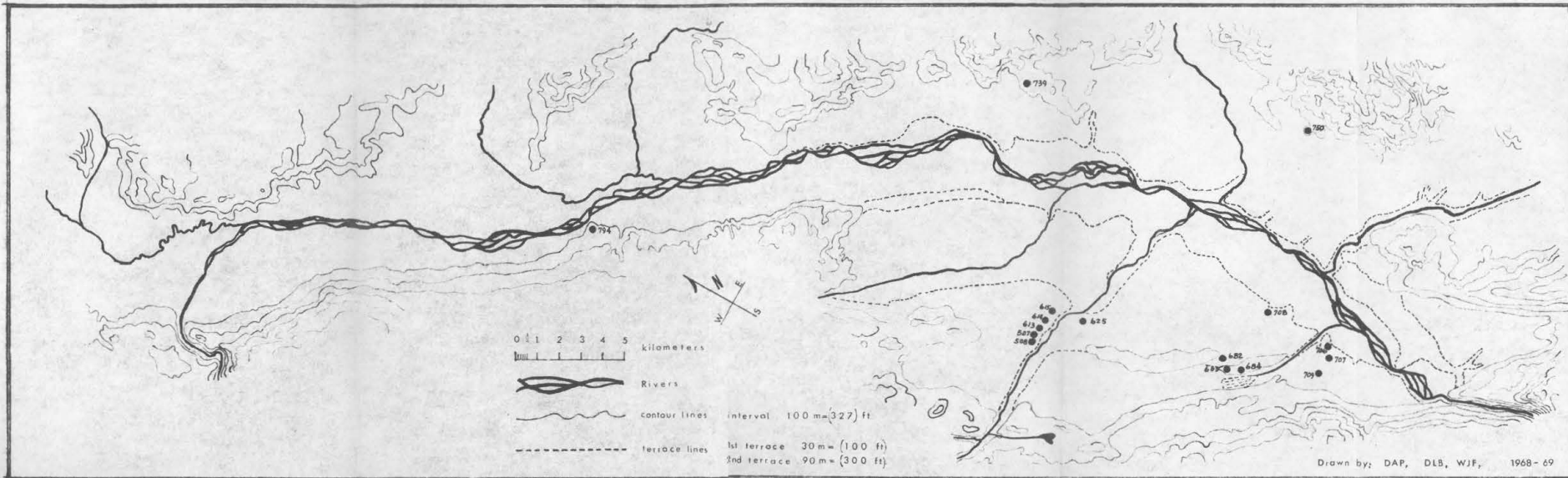

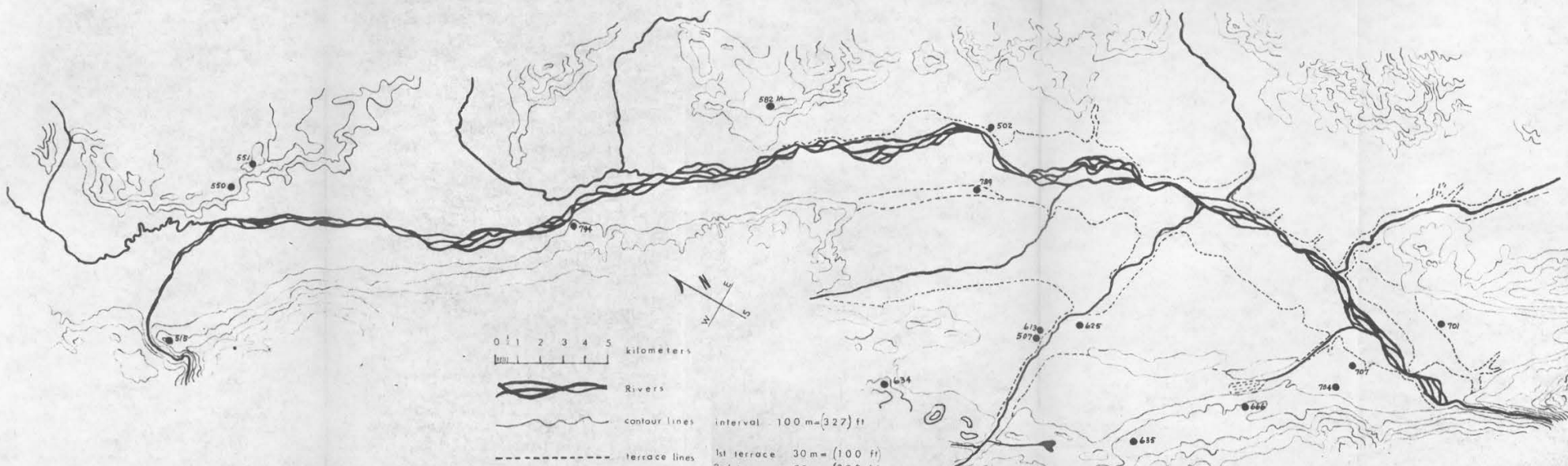

0 1 2 3 4 5 kilometers

Rivers

contour lines interval 100 m (327) ft

terrace lines 1st terrace 30 m (100 ft)
2nd terrace 90 m (300 ft)

Drawn by: DAP, DLB, WJF, 1968-69

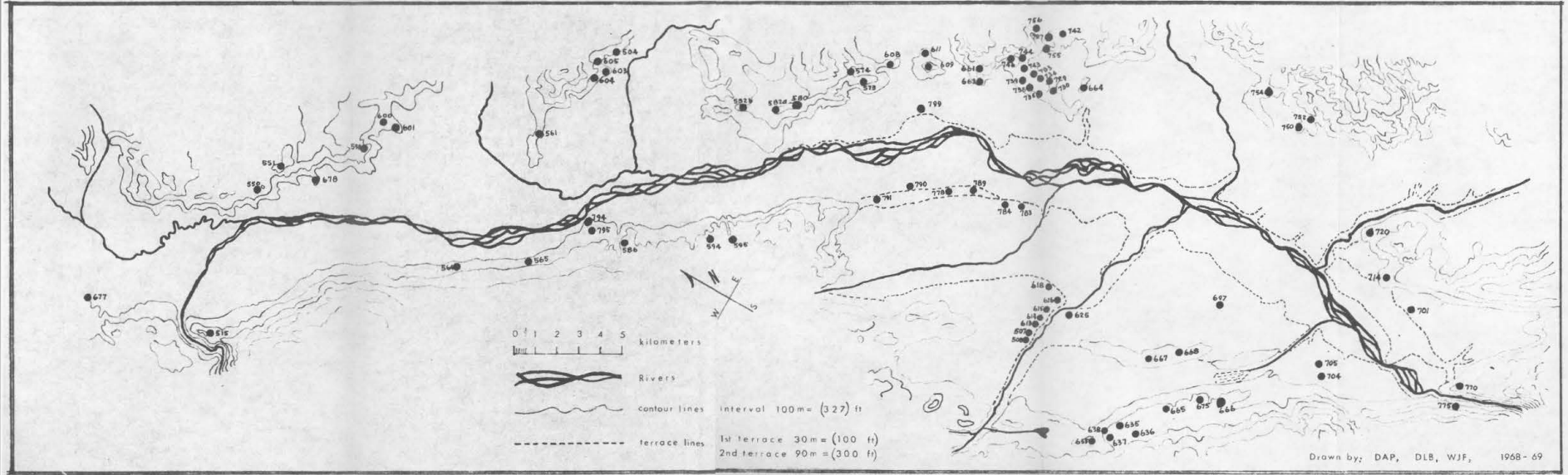

Drawn by: DAP, DLB, WJF, 1968-69

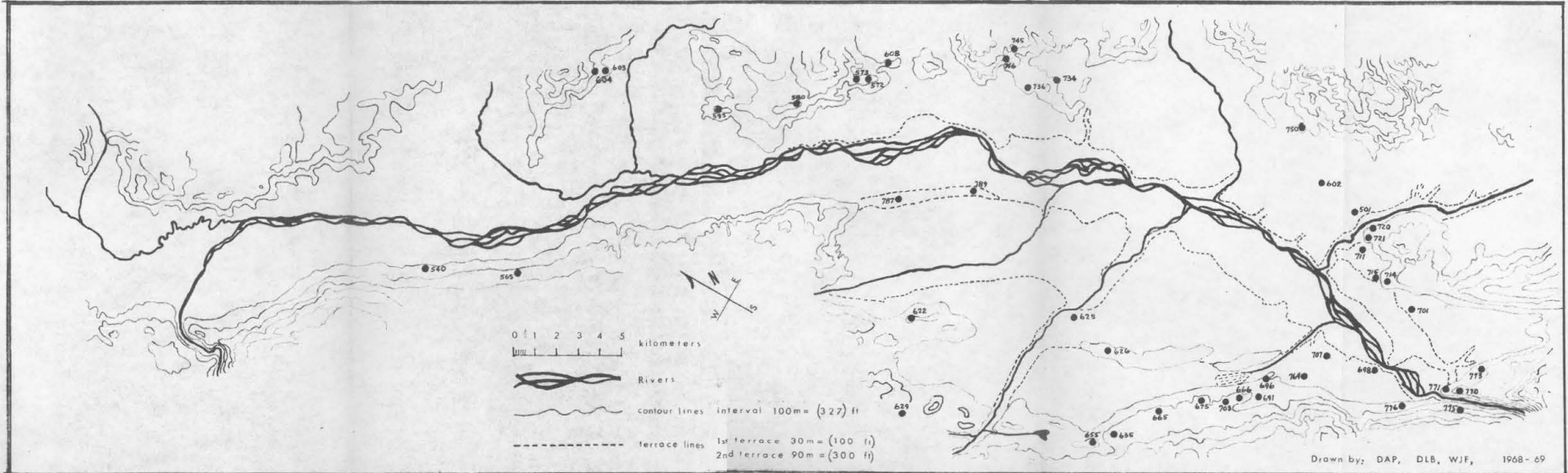

Drawn by: DAP, DLB, WJF, 1968-69

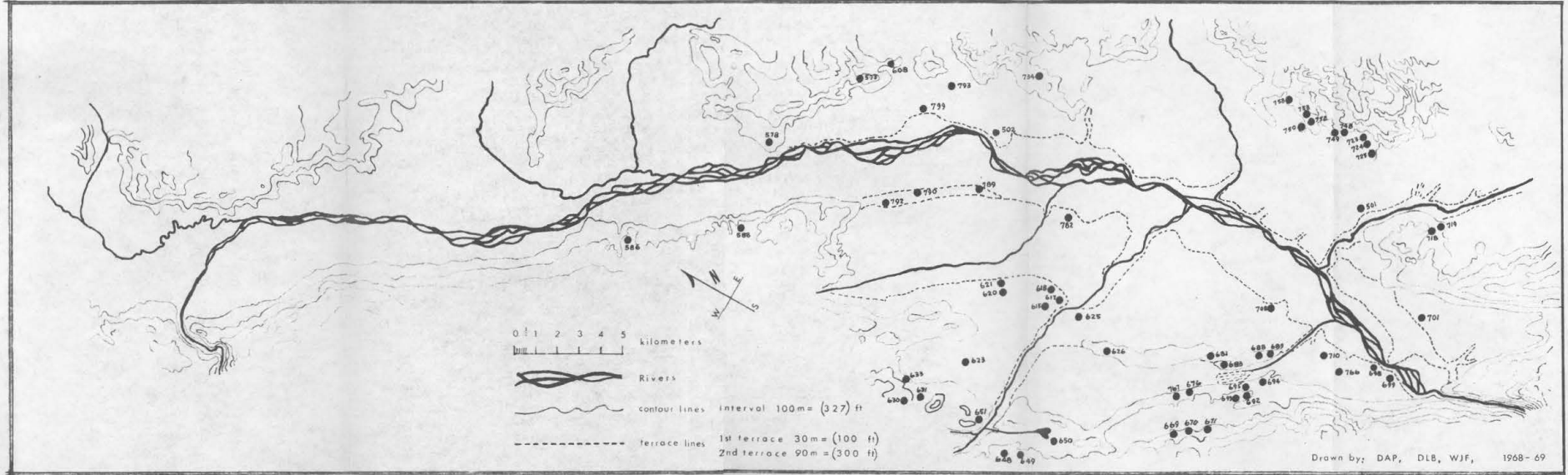

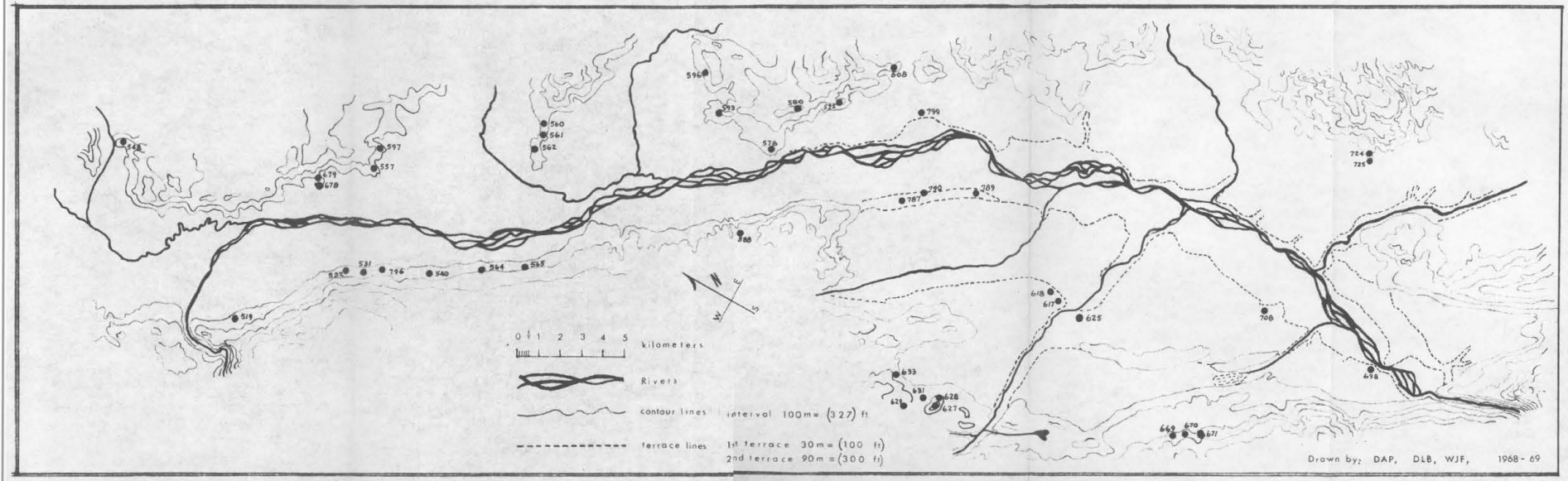

Drawn by: DAP, DLB, WJF, 1968-69

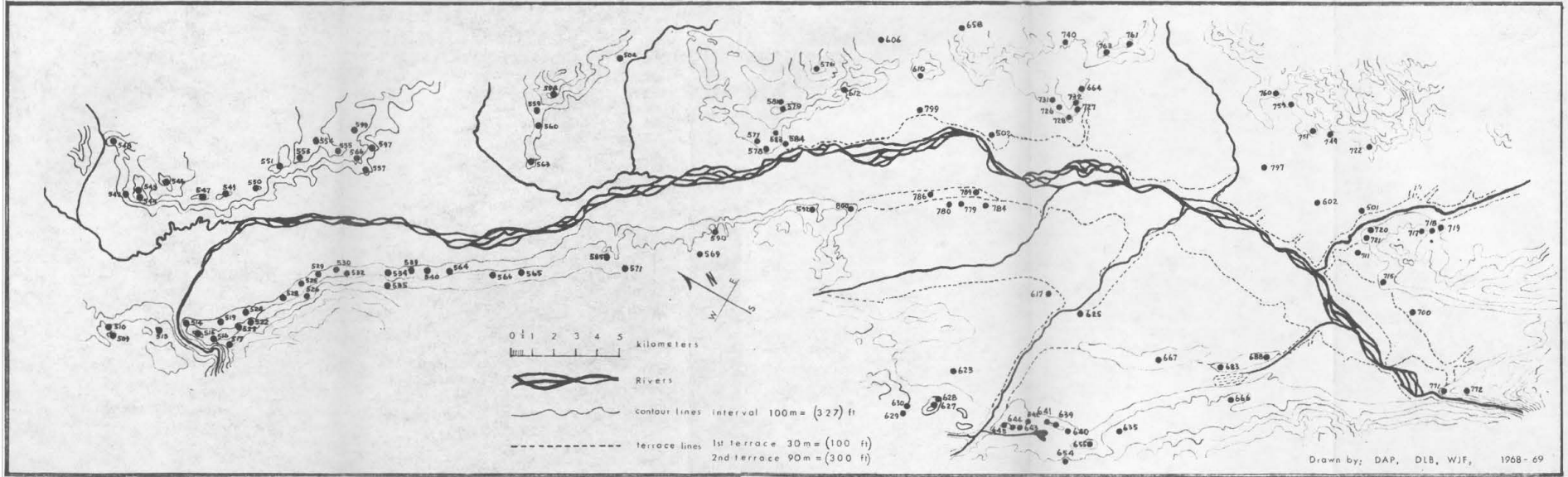

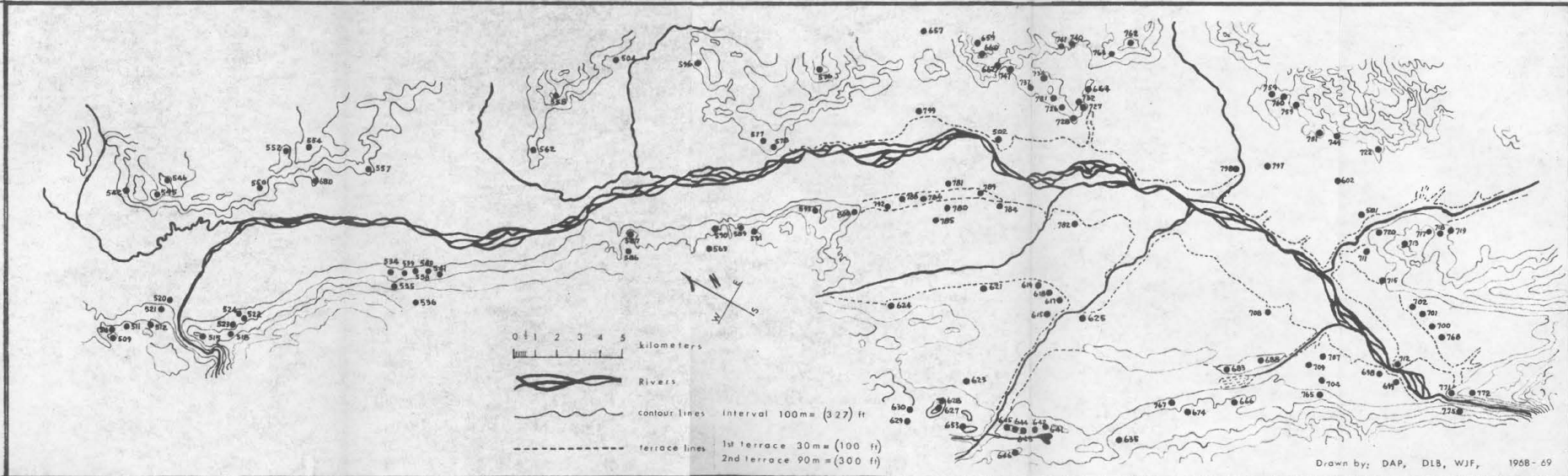

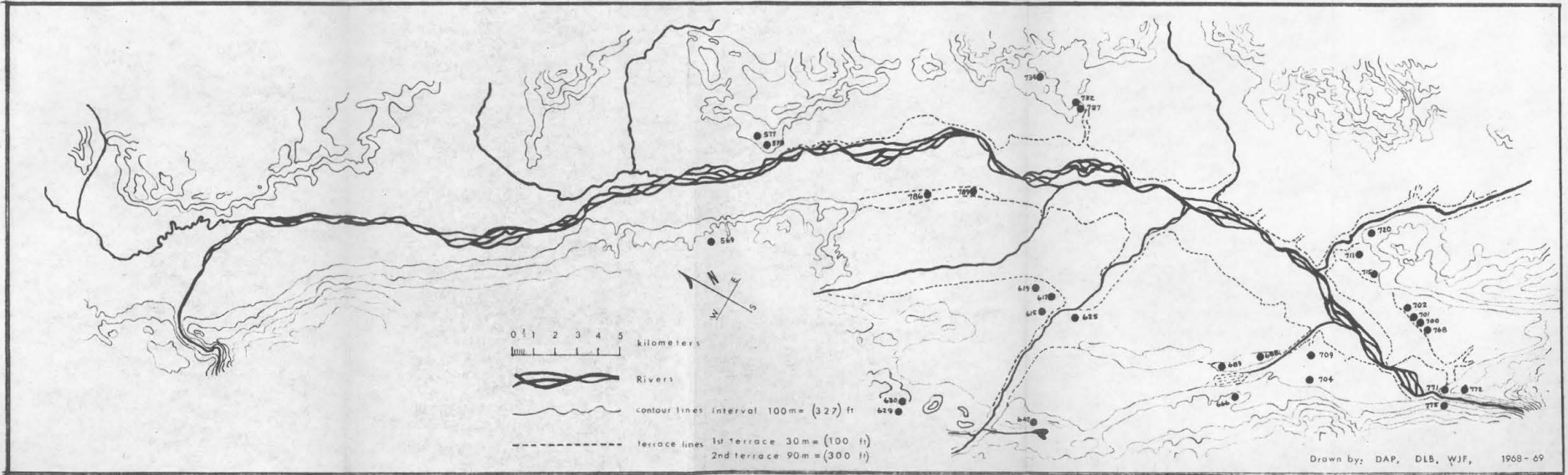

Drawn by: DAP, DLB, WJF, 1968-69

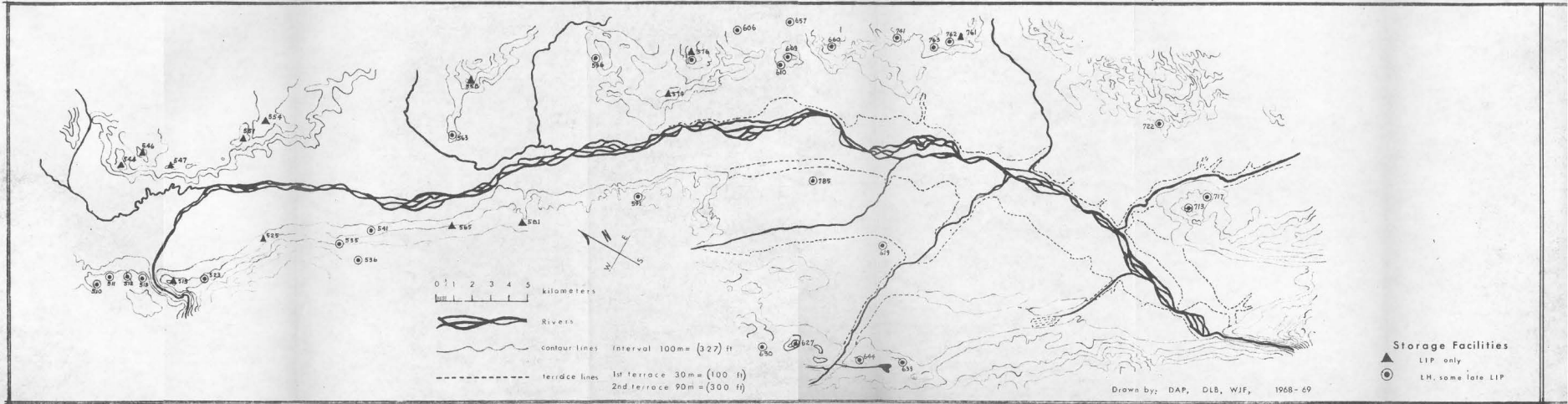

Fig. 1

- STRATUM 1 Loose, granular plow-zone
- STRATUM 2 Compact, gray-brown zone
- STRATUM 3A) Less compact, many concretions
- 3B) Grades gray-brown from top to red-brown at bottom
- 3C) Arbitrary divisions into 3A, 3B & 3C, each 20-30 cm
- STRATUM 4 Black-gray-red clay, zone of fire hearths and fire burnt earth
- STRATUM 5 Densely compact clay, blackish gray, sterile
- STRATUM 6 Loose, granular housepit fill, full of cobbles
- STRATUM 7 Very densely compact clay, orange-brown, sterile

PJUM 613
Profile North Wall

SCALE 0 1/2 1 2 meters

1969 DLB W.J.F

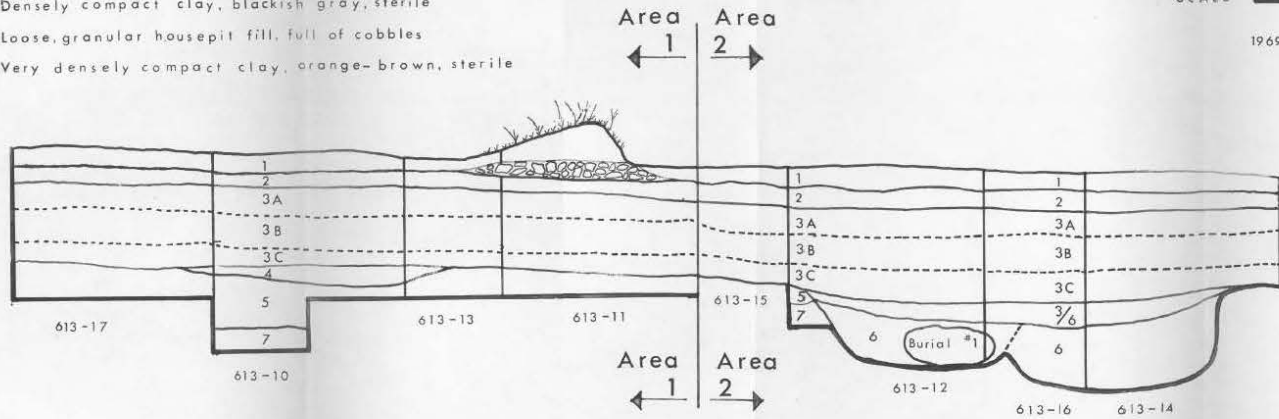

Fig. 2

- 1 Recent surface disturbed
- 2 Gray-brown granular, many cobbles
- 3 Tan-brown to buff, more compact, few cobbles
- 4 Sterile, decaying angular yellow-gray to white-gray rocks

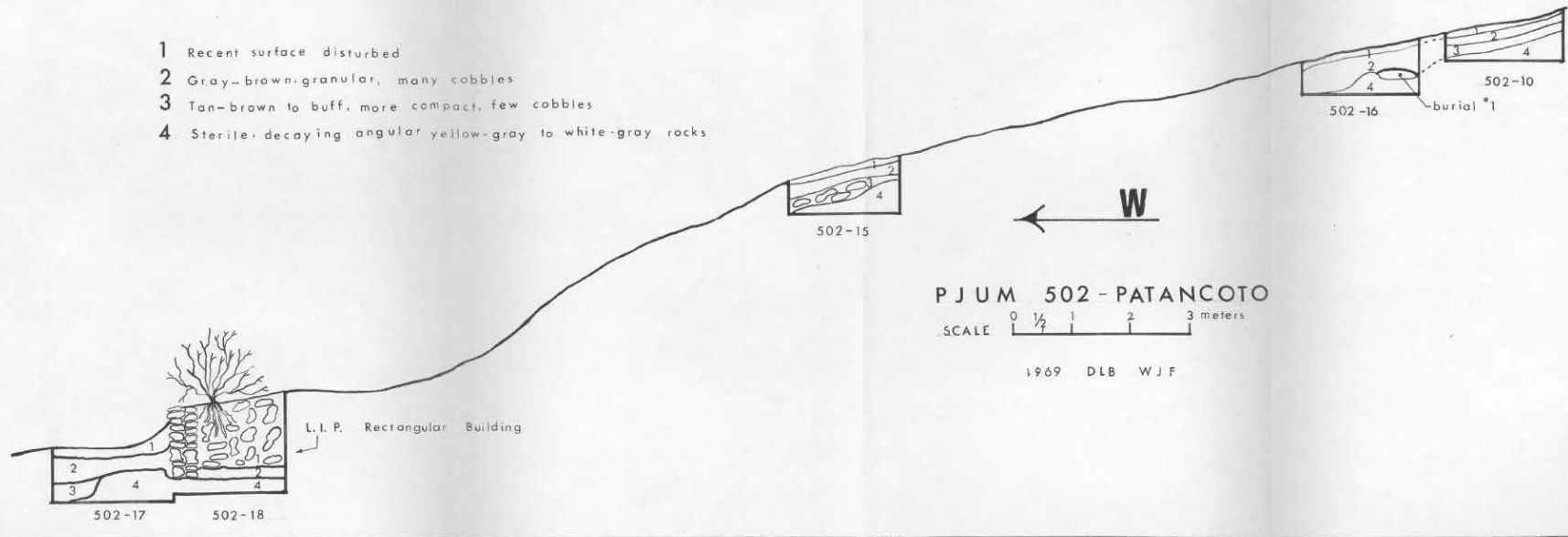

Fig. 3

PJUM 614-10

Acclahuasi-Pithouse Section

SCALE 0 1/2 1 2 meters

1969 DLB WJF

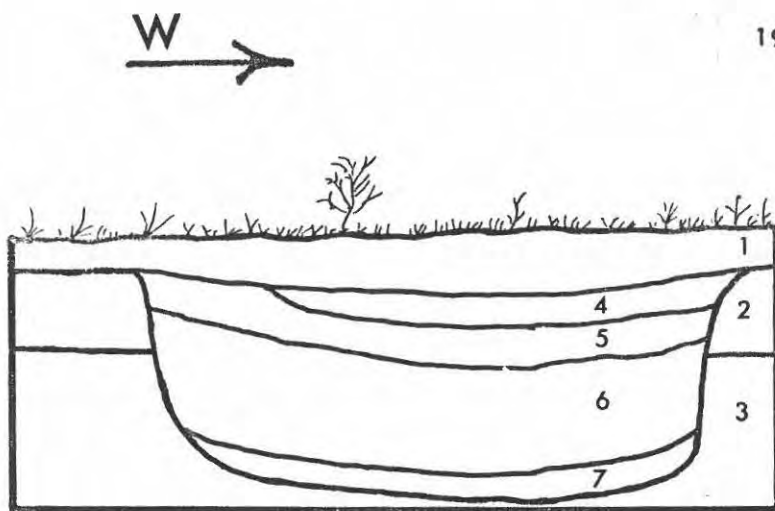

- 1 Brown, silty, plow zone
- 2 Calcreted, whitish-gray, mainly cemented gravel
- 3 Gray to orange-gray alluvial gravels
- 4 Gray-black ash lens
- 5 Tan-brown loose dirt & cobbles
- 6 Gray-brown, with small lens of ash, charcoal, sherds & bones
- 7 Coarse sand floor, sherds & charcoal on top

Fig. 4

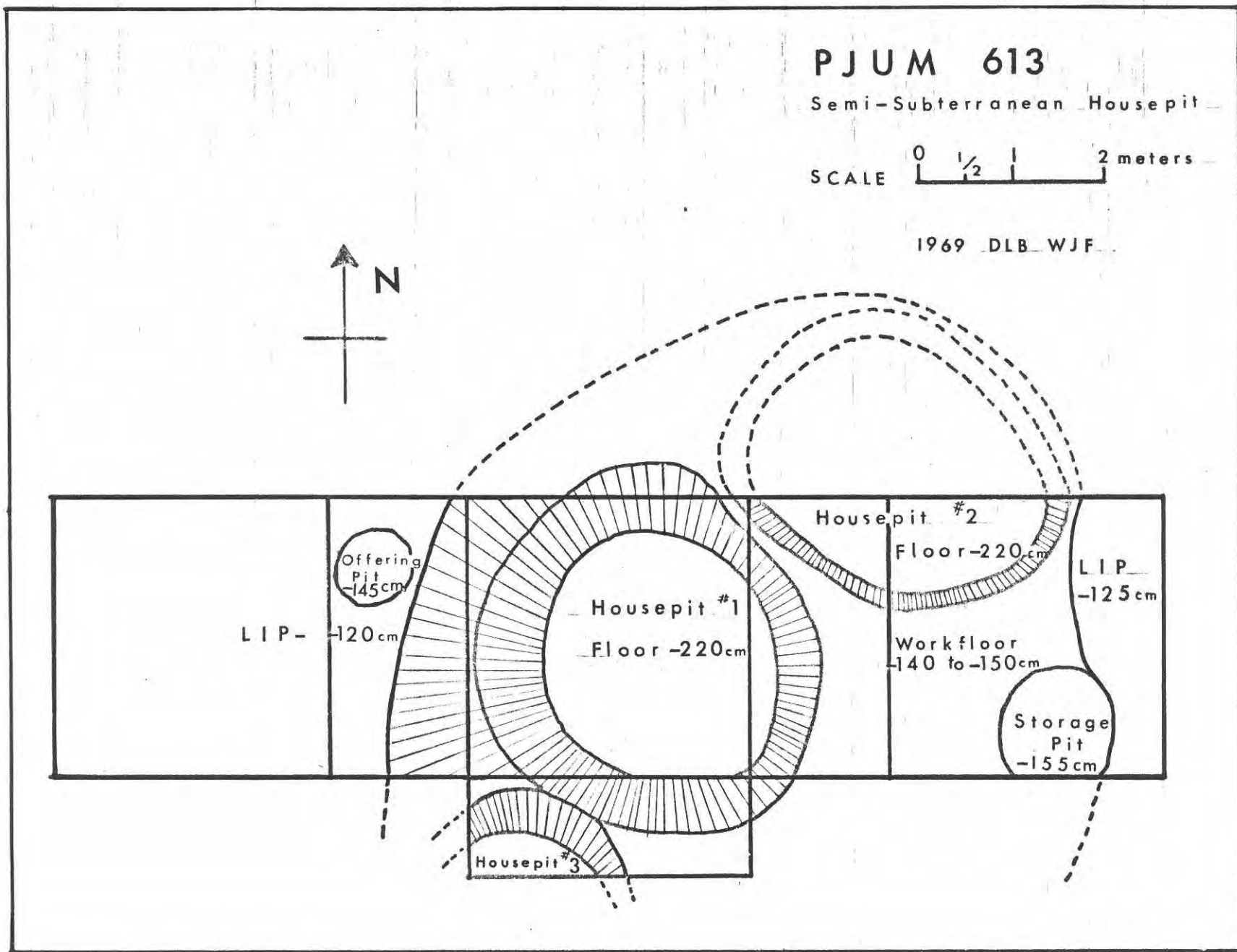
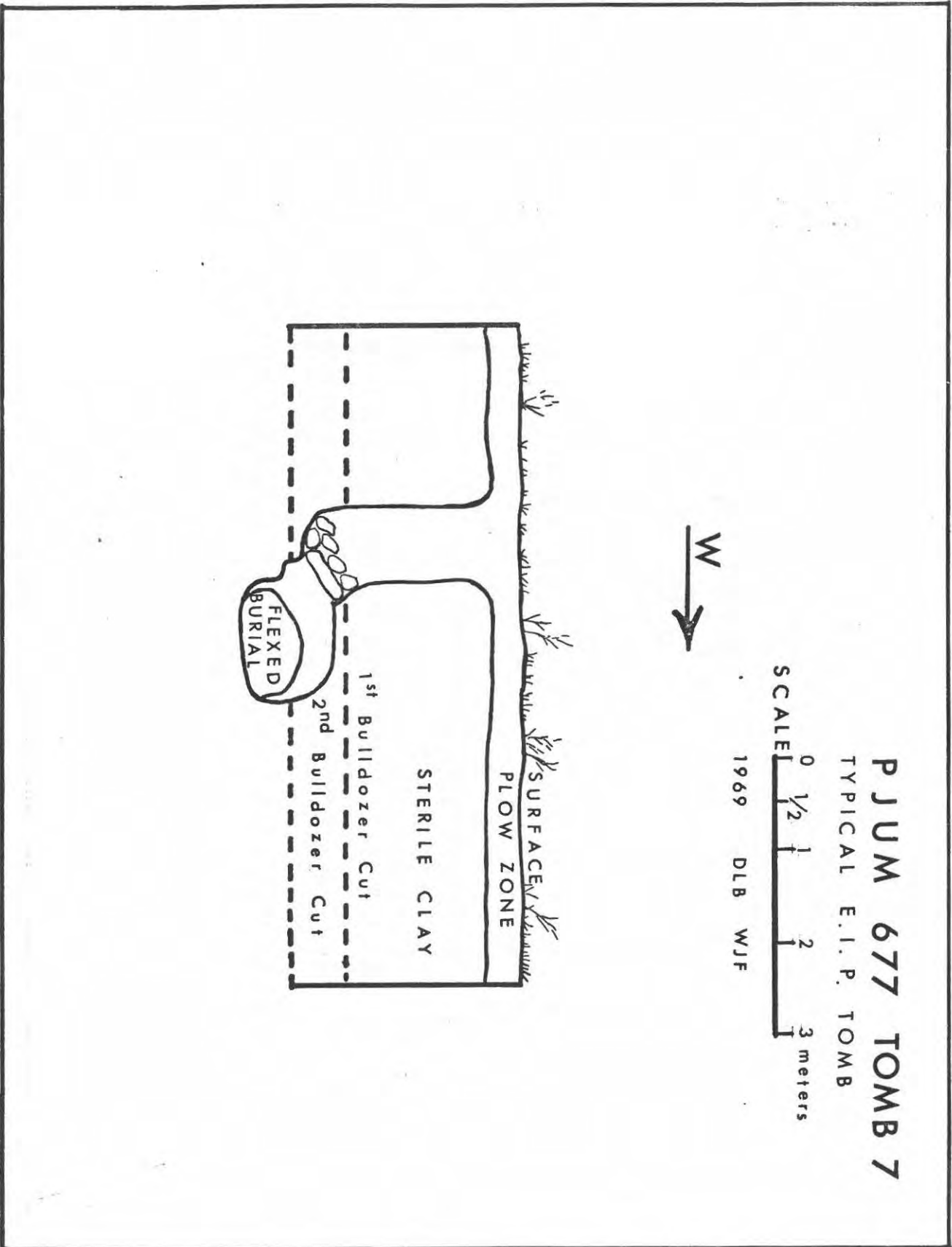

Fig. 5



PJUM 625-10

0 1/2 1 2 3 meters

1969 DLB WJF.

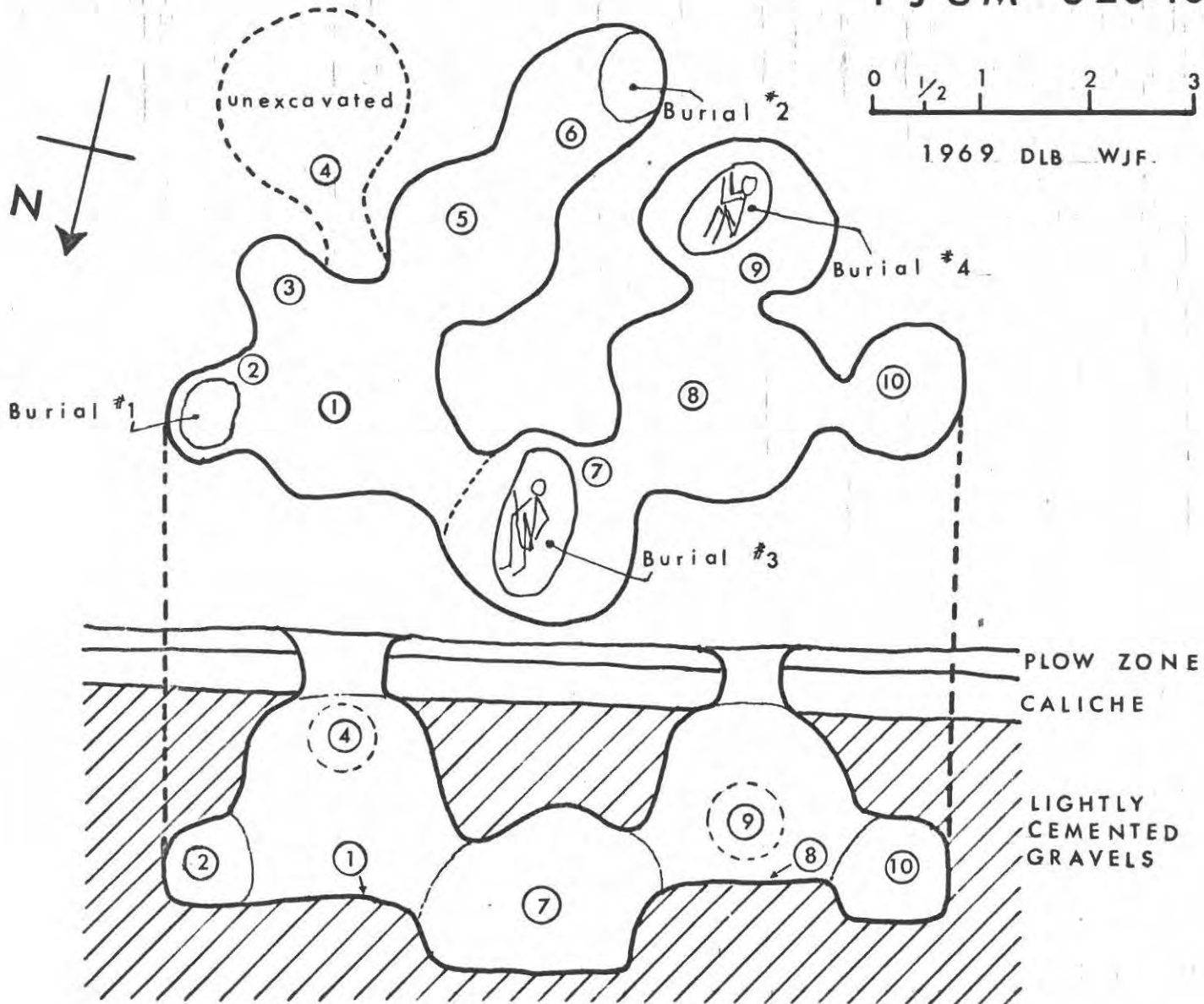
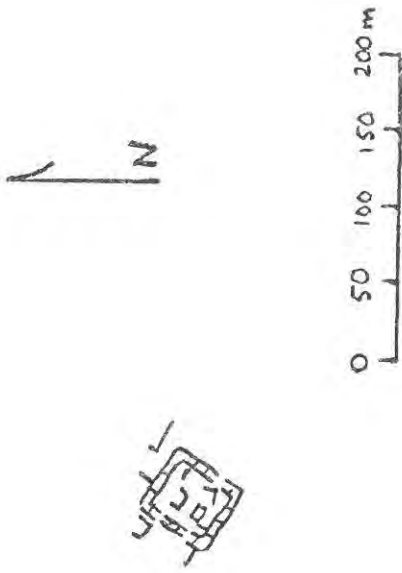

Fig. 6

Fig. 7



PJum 501
WARIWILKA



PJum 618
CALPISH



PJum 648
NAHUIN PUQUIO

MIDDLE HORIZON TEMPLES

Fig. 8

PJUM 618-1E

CALPISH-OVAL "TEMPLE"

WEST WALL SECTION

SCALE 0 1/2 1 2 3 meters

1969 DLB WJF

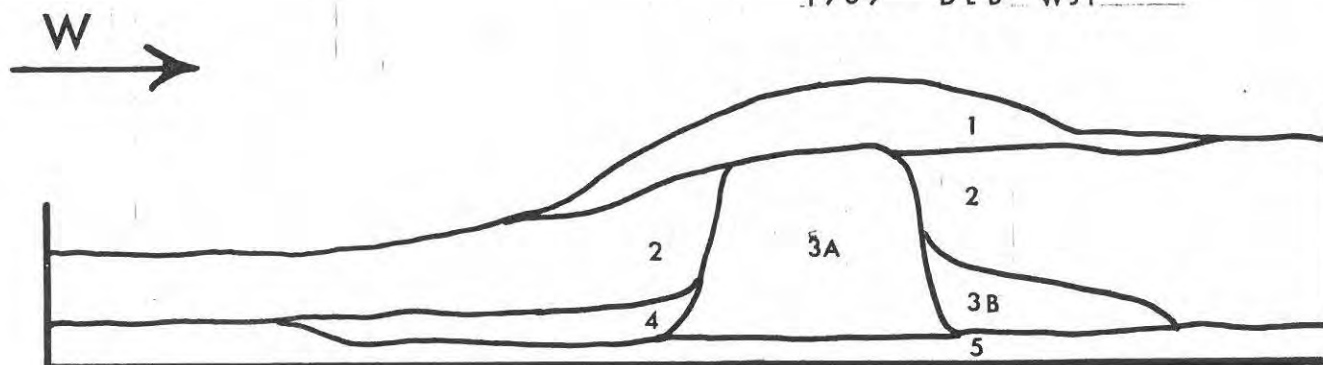

- 1 Loose field stone-pile
- 2 Compact gray-brown soil, scattered stone
- 3A Round field cobbles with brown mud mortar
- 3B Wall slump of 3A
- 4 Midden of small cracked stone, sherds, bones, etc
- 5 Sterile, orange-brown clay

PJUM 525-10

SQUARE BUILDING SECTION

SCALE 0 1/2 1 2 3 meters

1969 DLB WJF

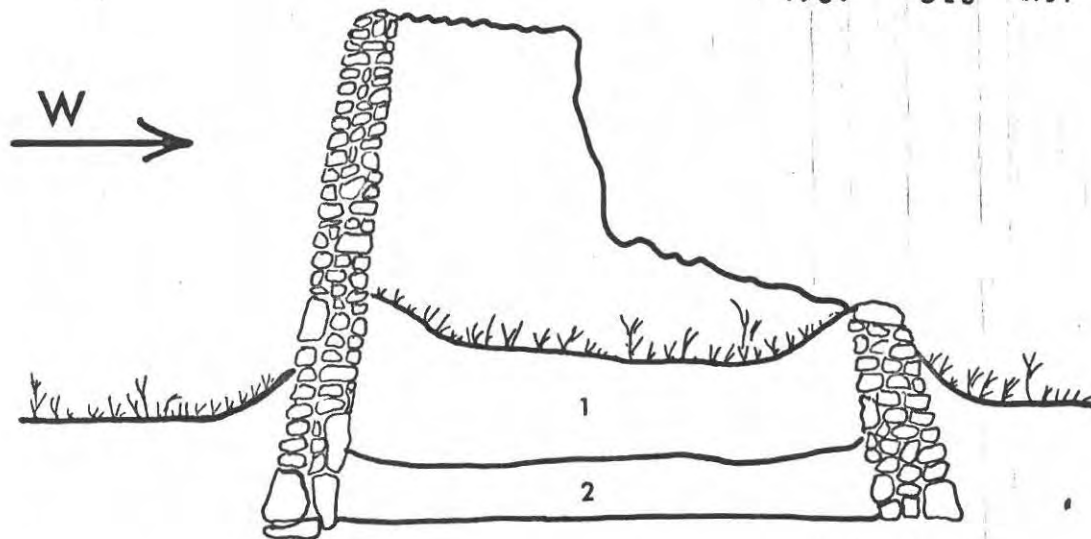

1 LOOSE WALL SLUMP

2 LOOSELY COMPACT, ORANGE-BROWN CLAYEY SOIL

Fig. 10

PJUM 536

CIRCULAR STORAGE BUILDING

SCALE 0 1/2 1 2 3 meters

1969 DLB WJF

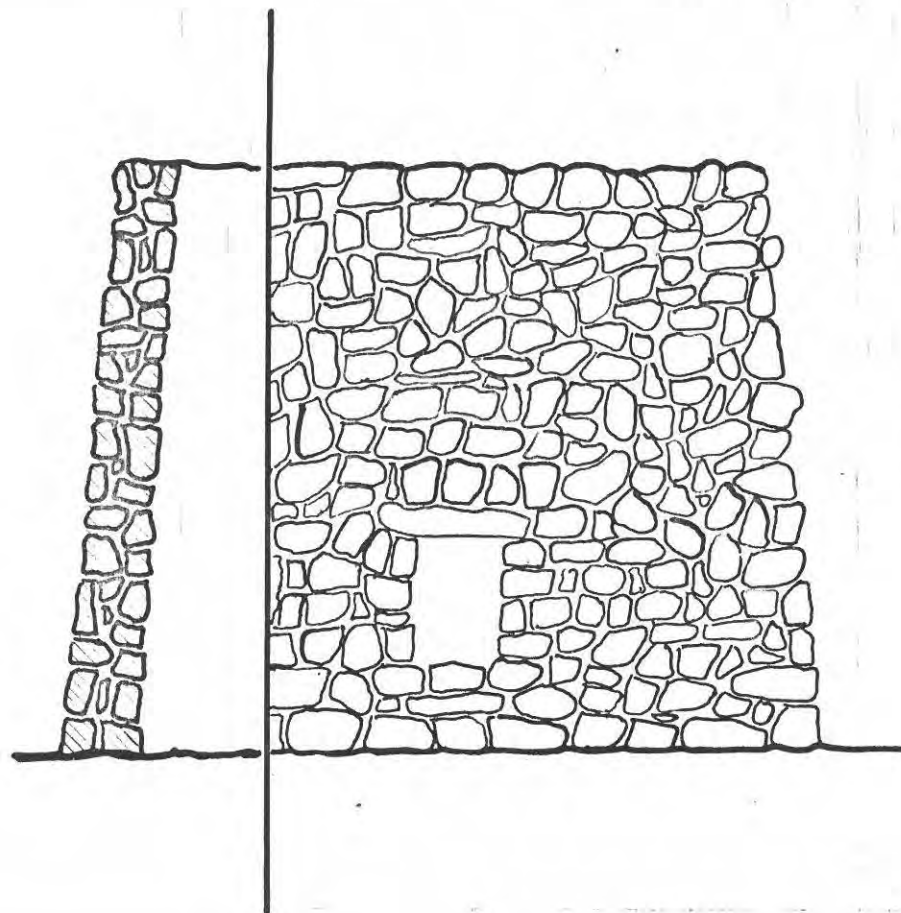

CIRCULAR
DOUBLE WALL
50-60 cm Thick

PJUM 576

RECTANGULAR STORAGE BUILDING

SCALE 0 1/2 1 2 3

1969 D.L.B. W.J.F.

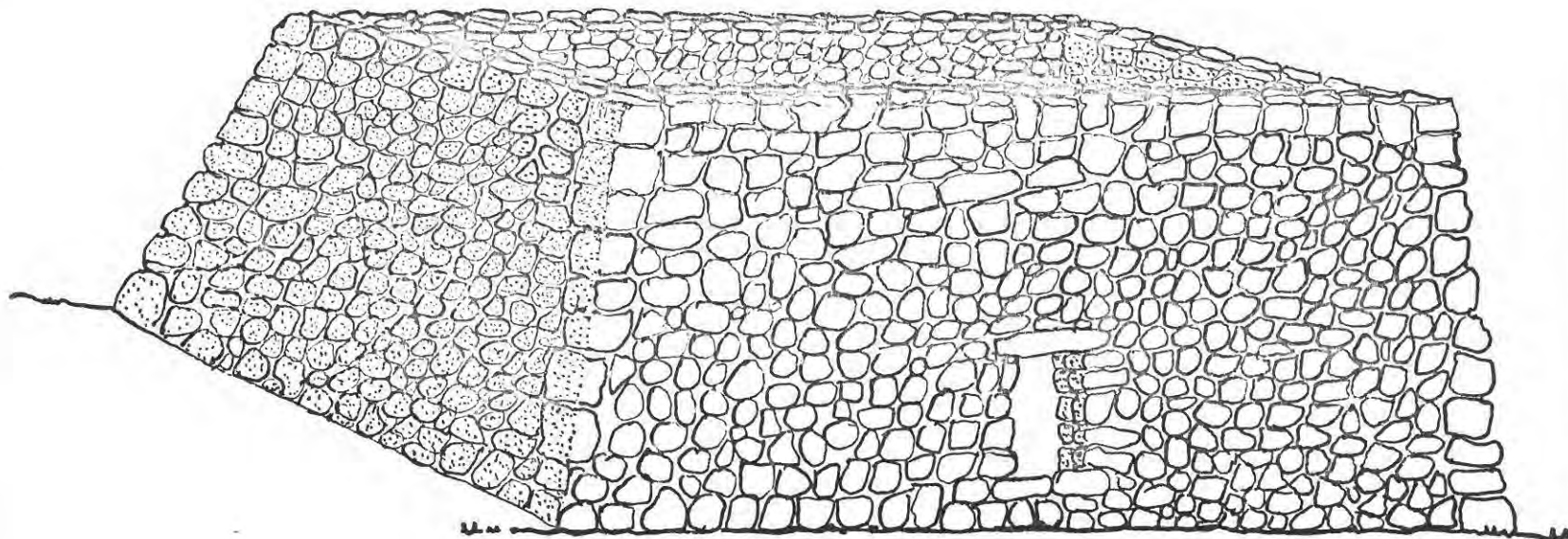
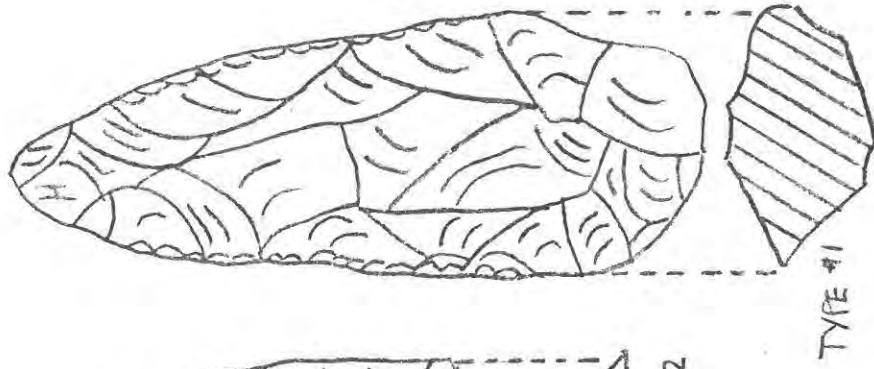

Fig. 11

DOUBLE WALL 50-60 cm Thick

Fig. 12



TYPE #1

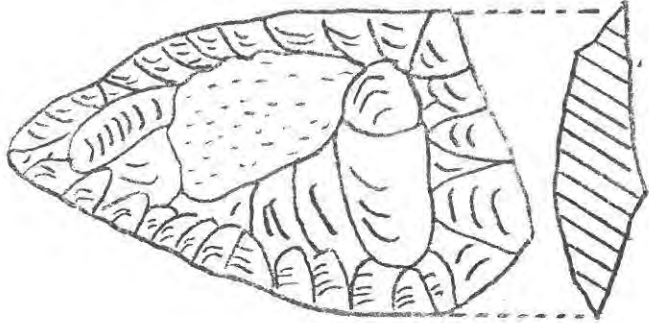

TYPE #2

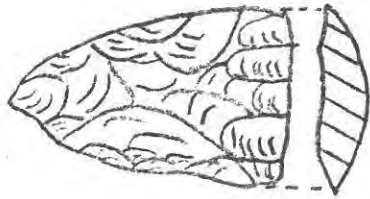

TYPE #3

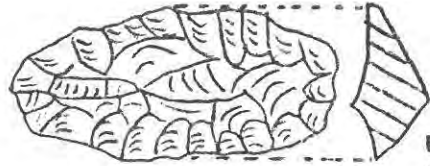

TYPE #5

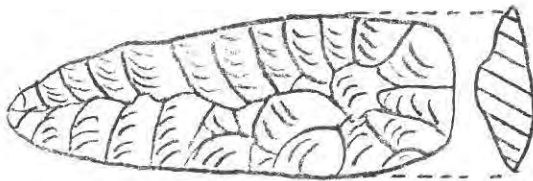

TYPE #4

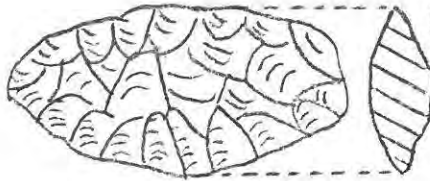

JURPAC POINTS

Fig. 13

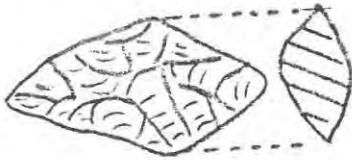
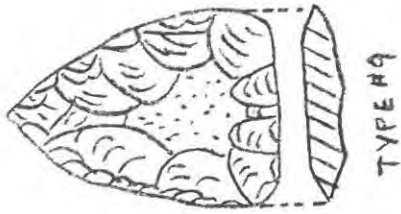
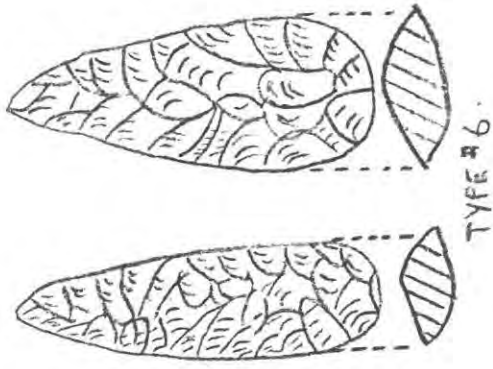

POINTS

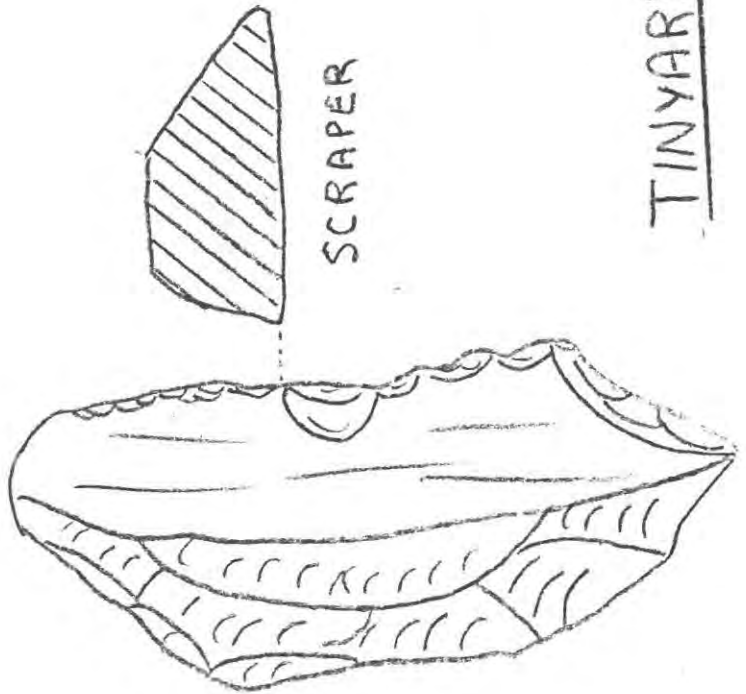
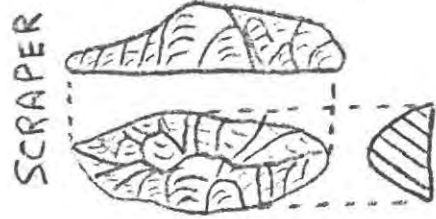

TINYARI-VARIOUS

Fig. 14

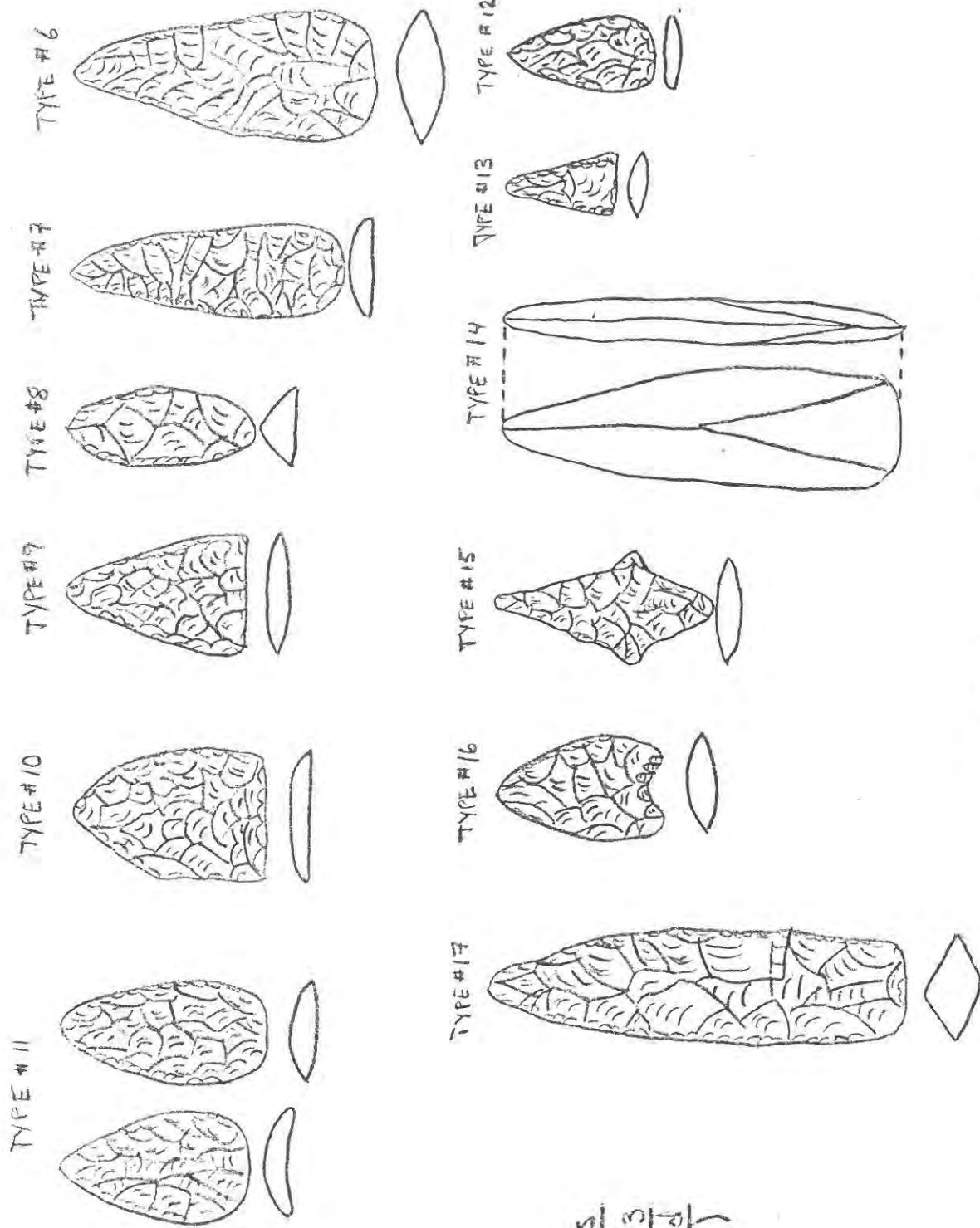

(includes
PSum 613
excavated
material)

EARLY HORIZON POINTS

Fig. 15

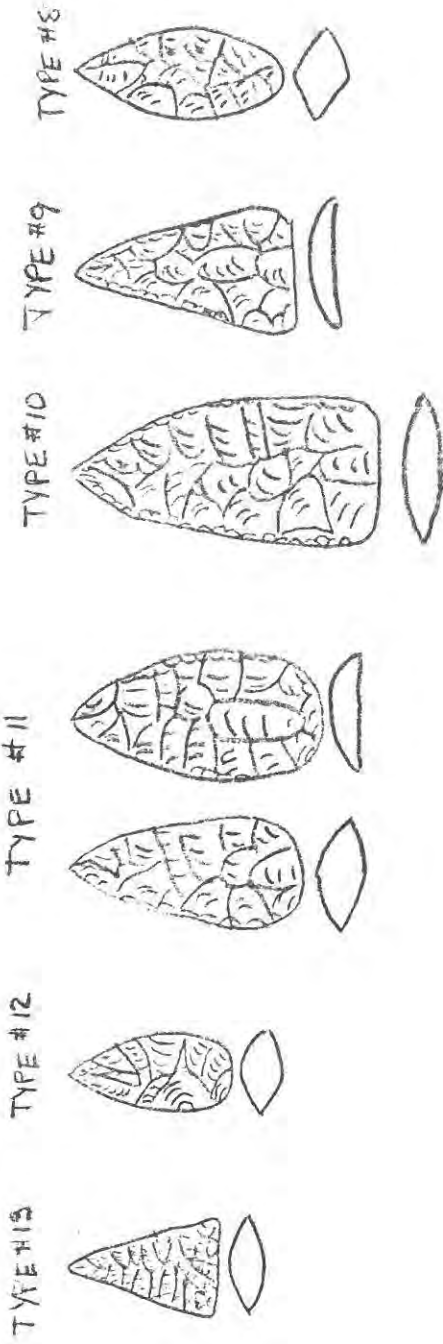

EARLY INTERMEDIATE PERIOD POINTS

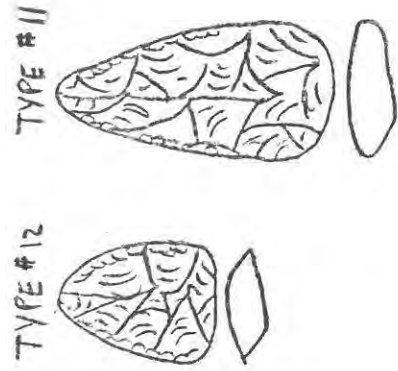

CALPISH MIDDLE HORIZON POINTS

Fig. 16

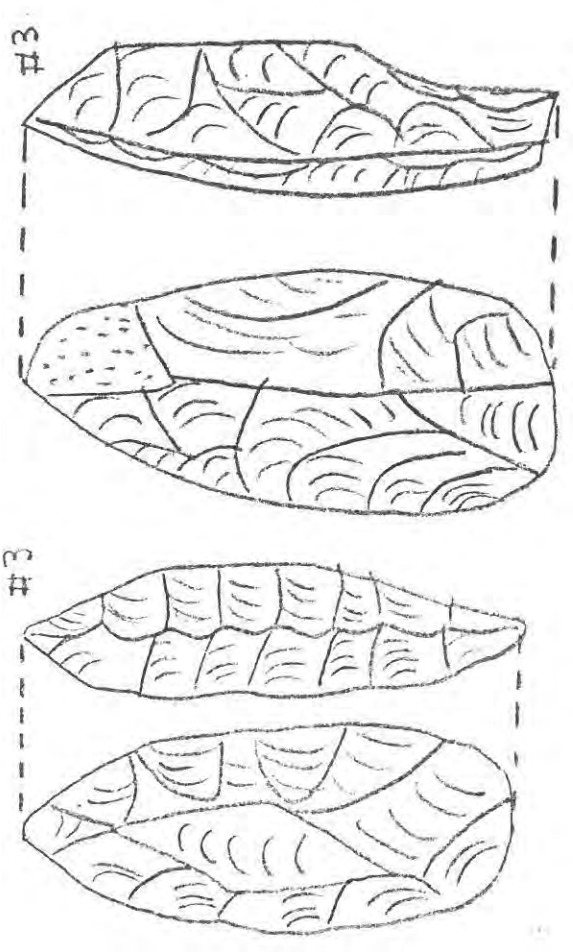
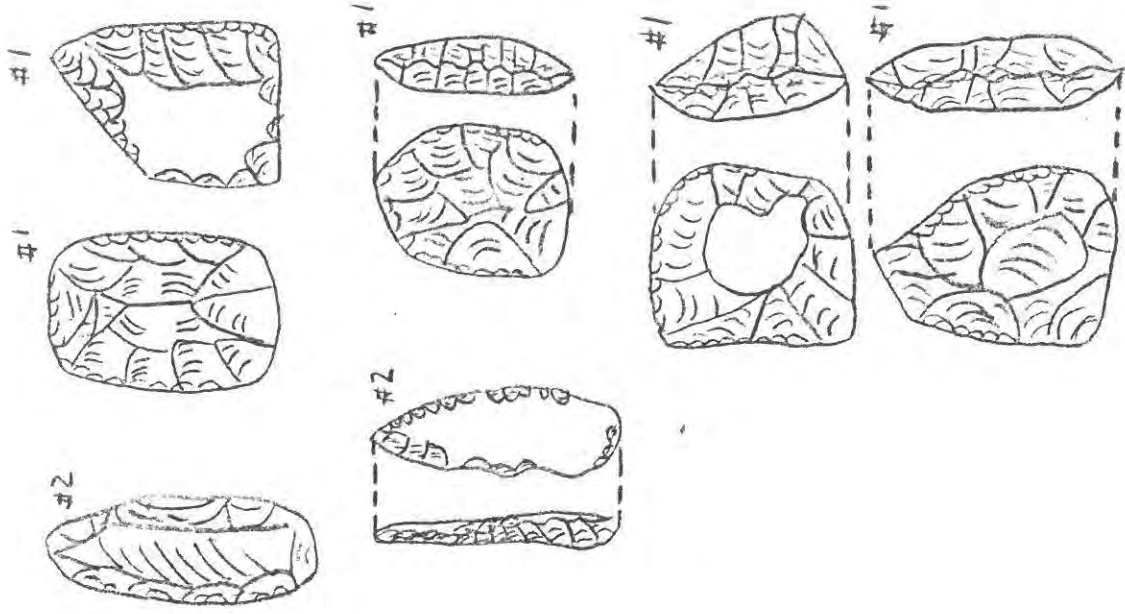

PJUM 613 BIFACES

COCHACHONGOS

DOUBLE-BITTED GRAUER

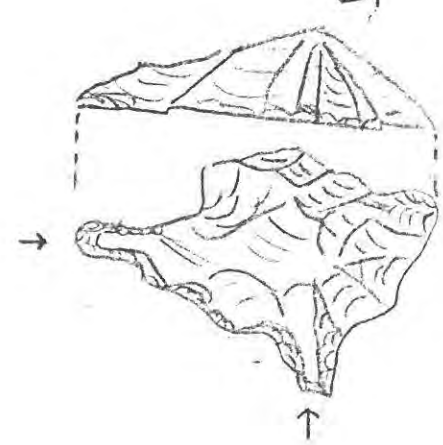
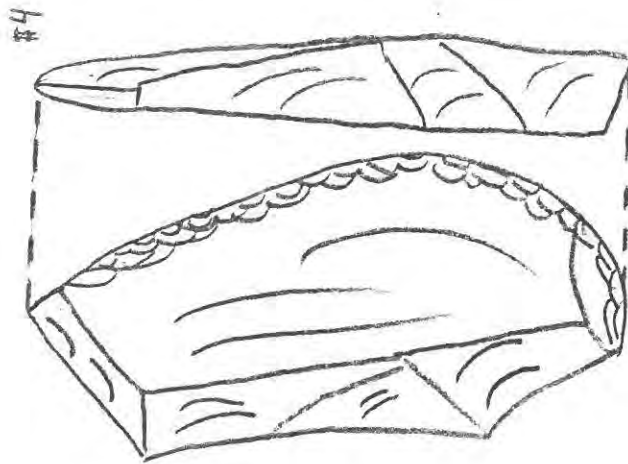
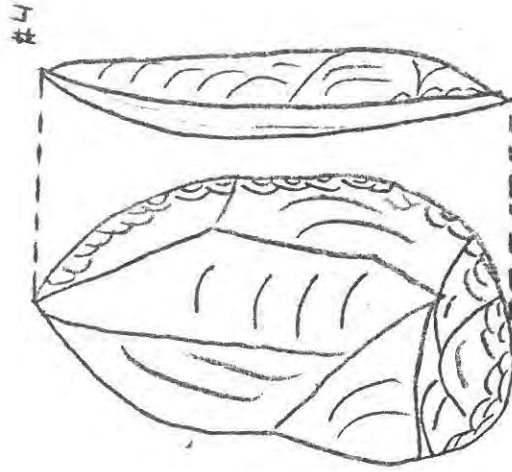
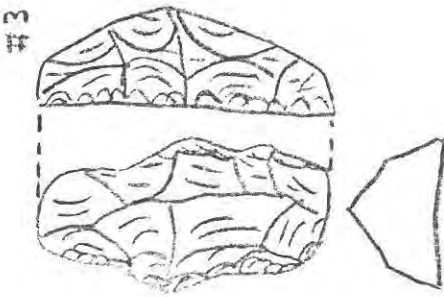
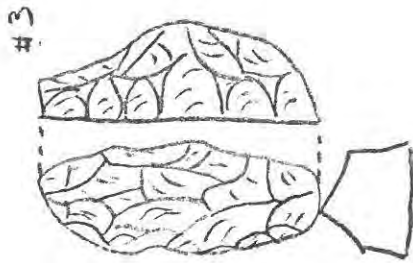
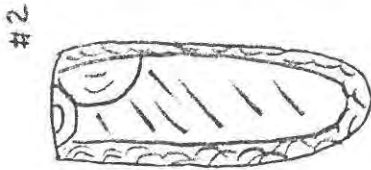
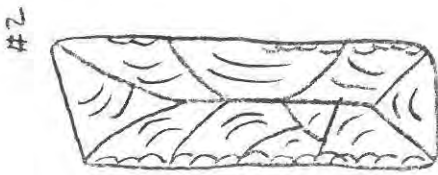
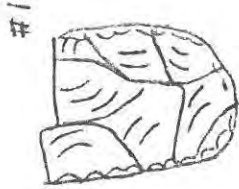
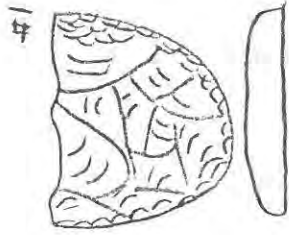

Fig. 17



PJUM 613. SCRAPERS

COCHA CHONGOS

PJUM 613
CORE BIFACES
COCHA CHONGOS

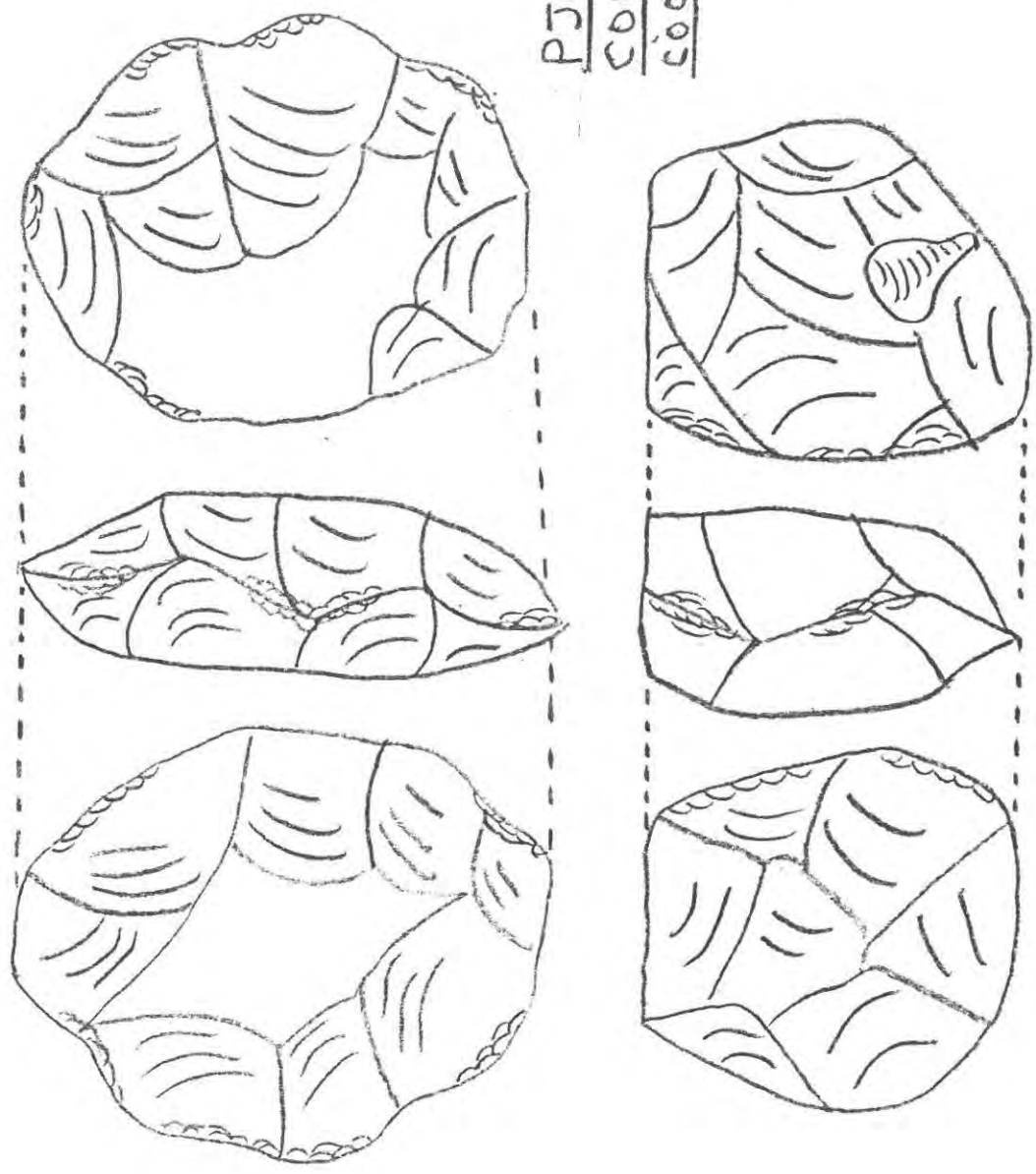
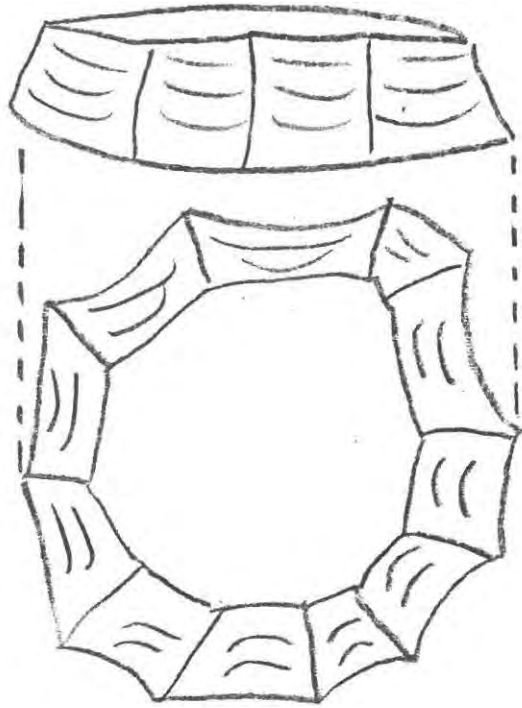
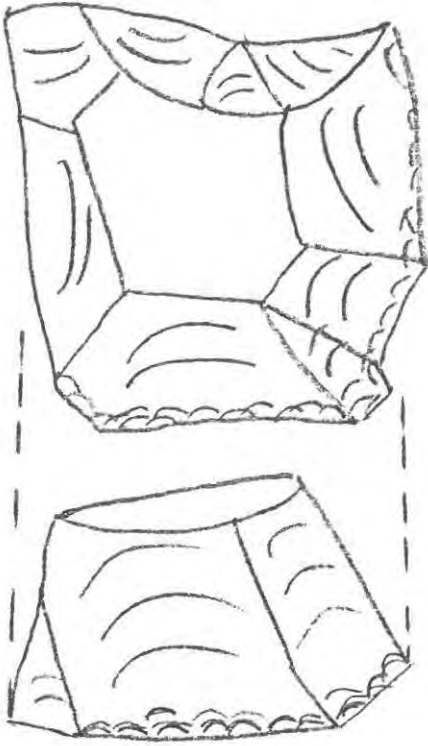
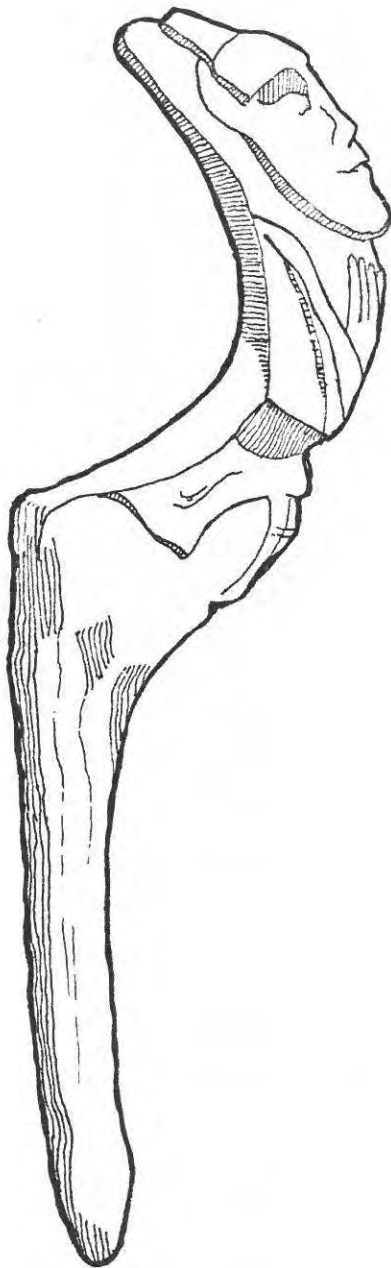

Fig. 19



PJUM 613
CORE SCRAPER PLANES
LOCHACHONGOS

ATL-ATL
Handle Piece



SIDE

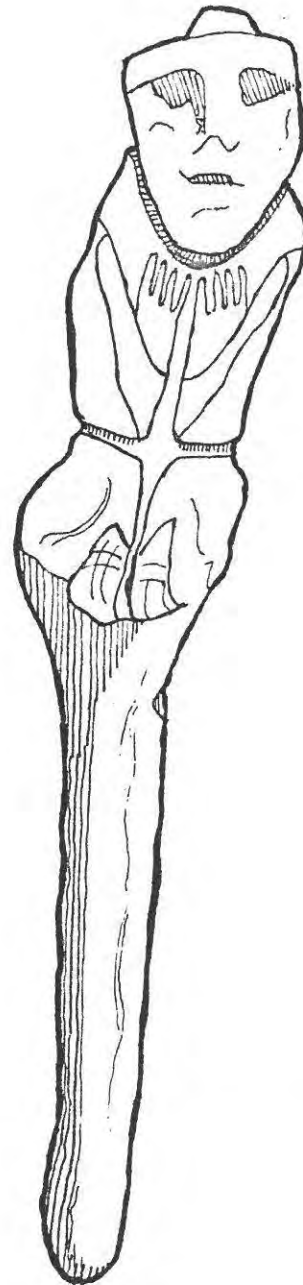

FRONT

twice actual size

Fig. 21

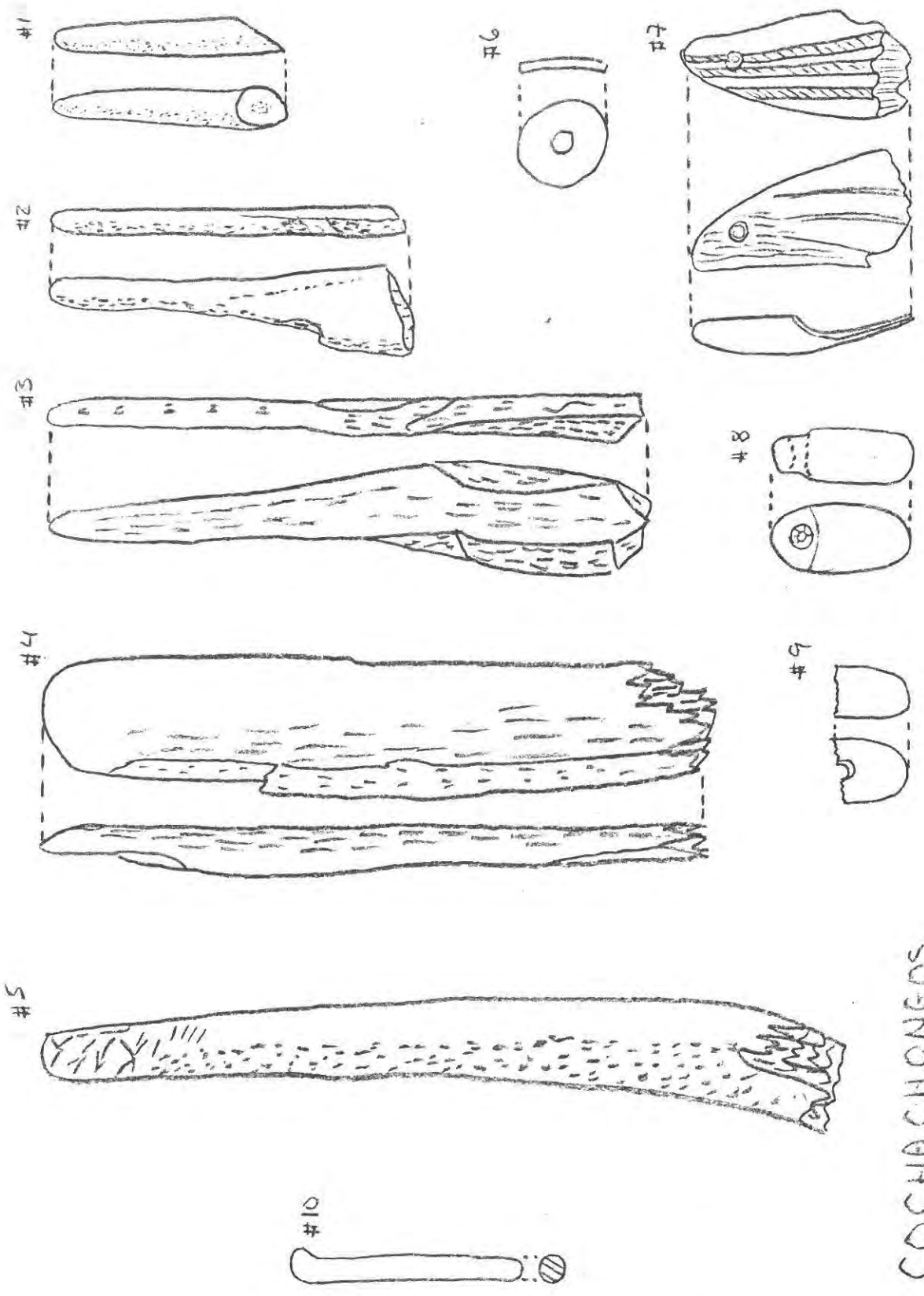

COCHACHONGOS
PSUM 613

Fig. 22

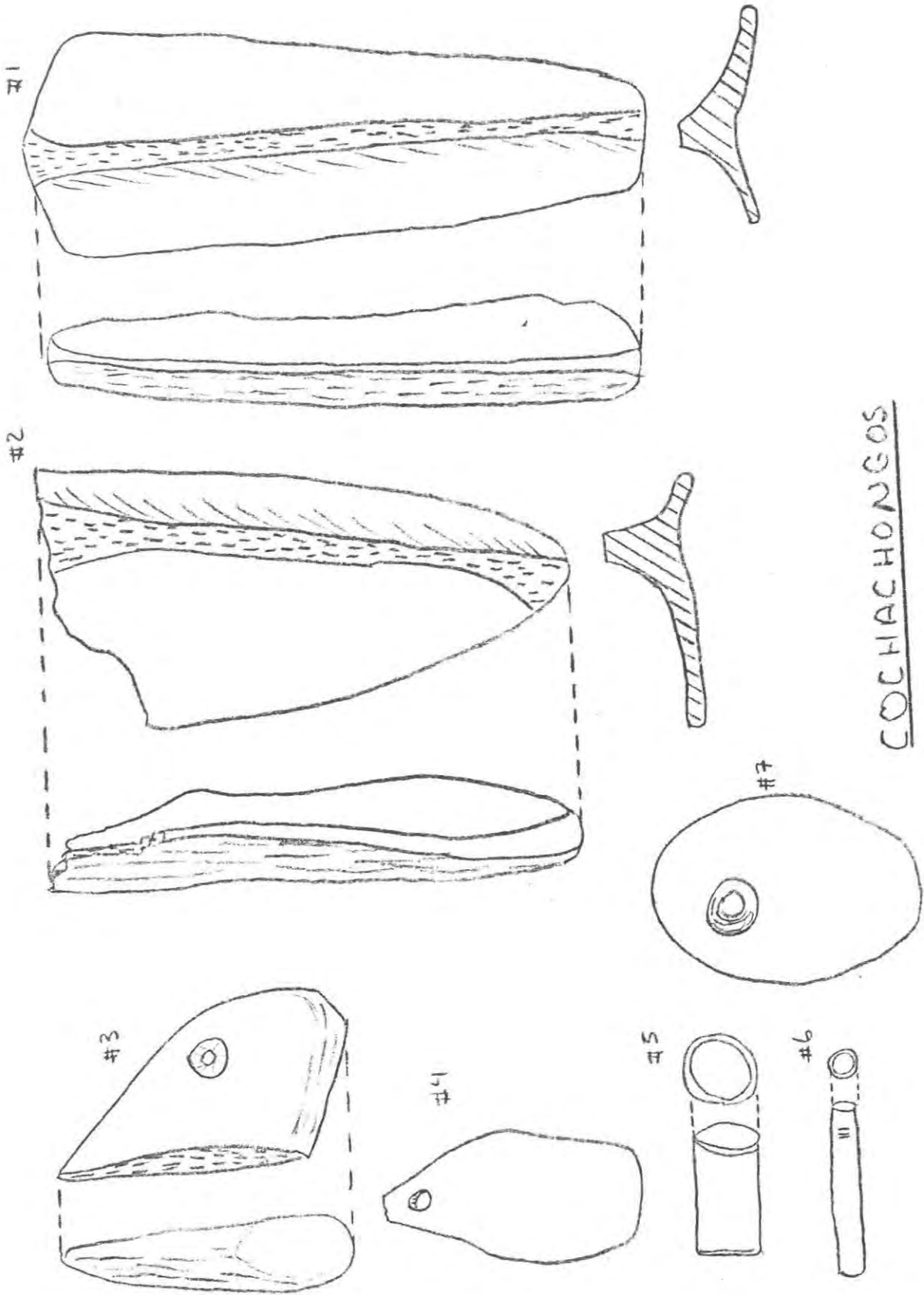

COCHACHONGOS

Fig. 23

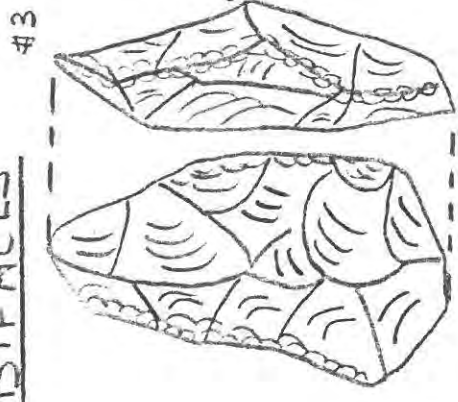
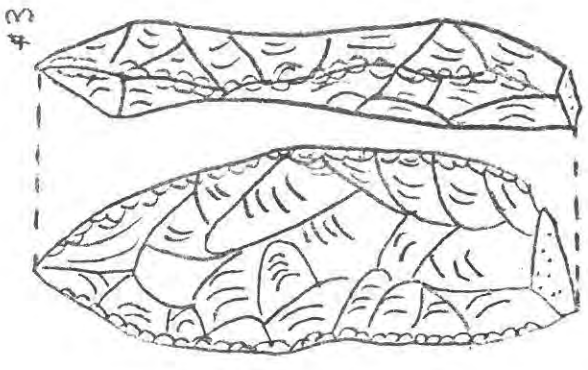
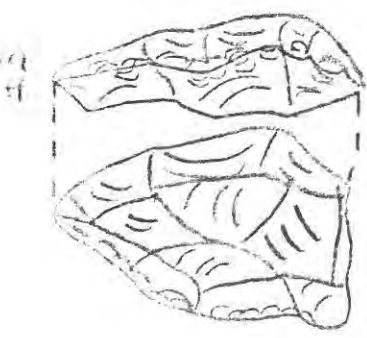
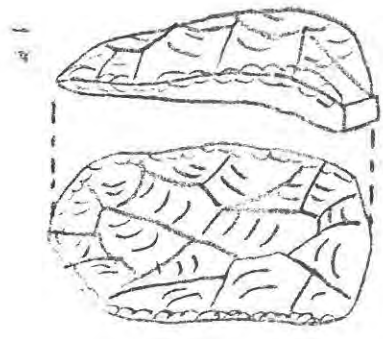
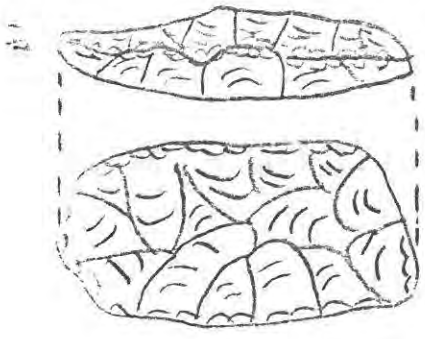
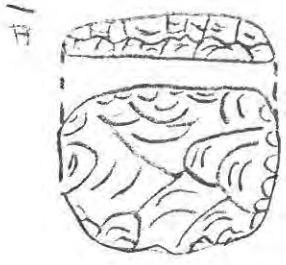
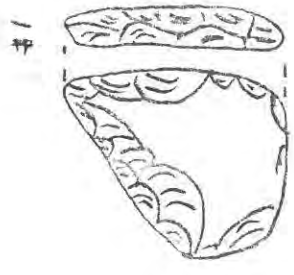

BIFACES

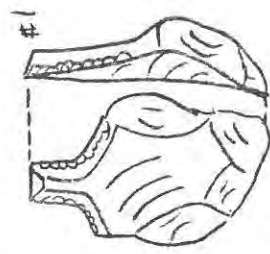

GRAVER

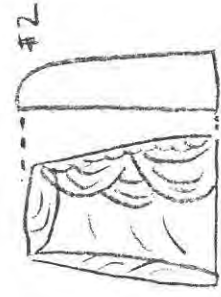
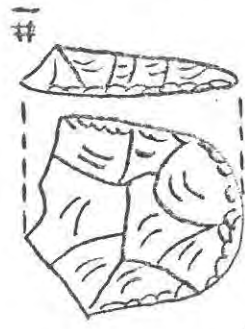

SCRAPERS

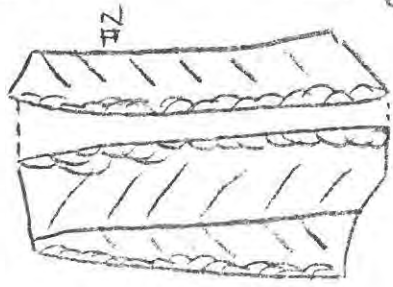
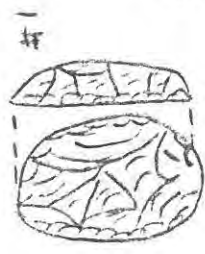

USUPUQWIO TOOLS

Fig. 24a

COCHACHONGOS P5um 613

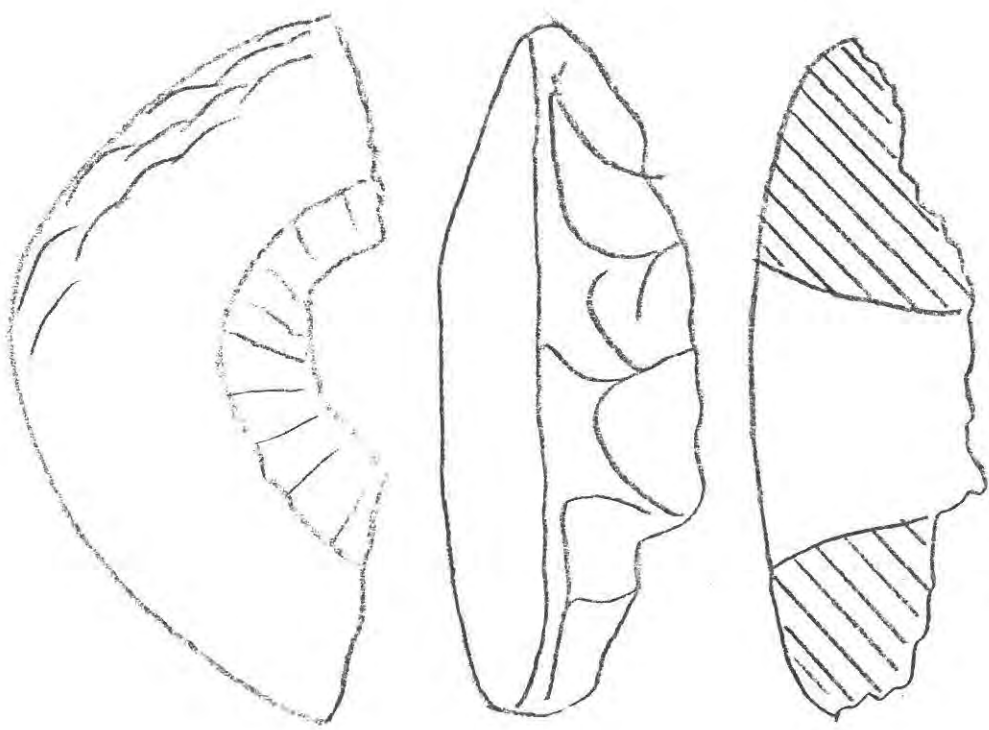
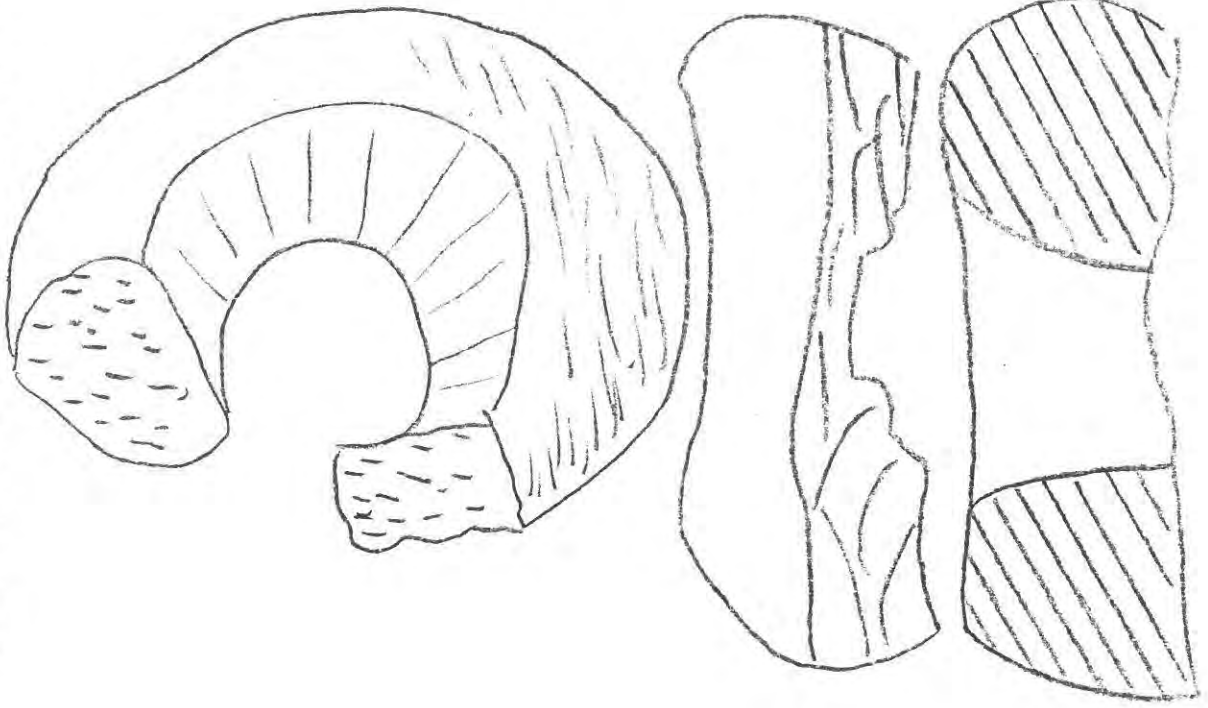

Wsupuquio

TYPE #1 DIGGING WEIGHT

Fig. 24b

USUPUQUIO

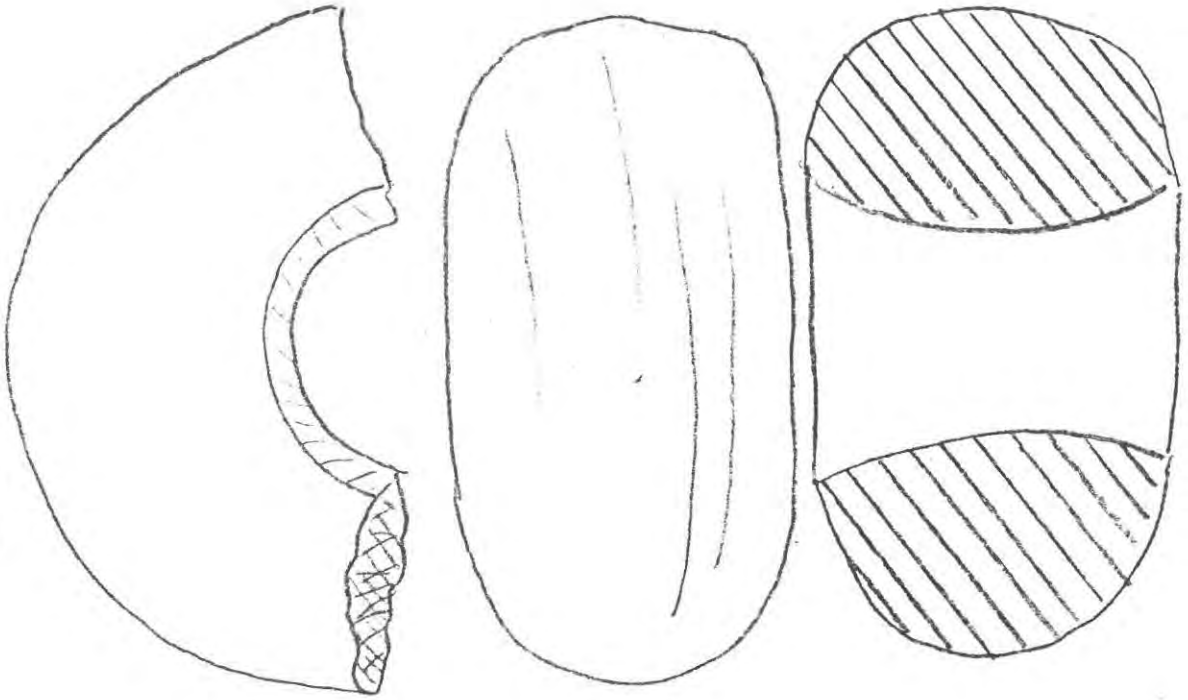

CALPISH

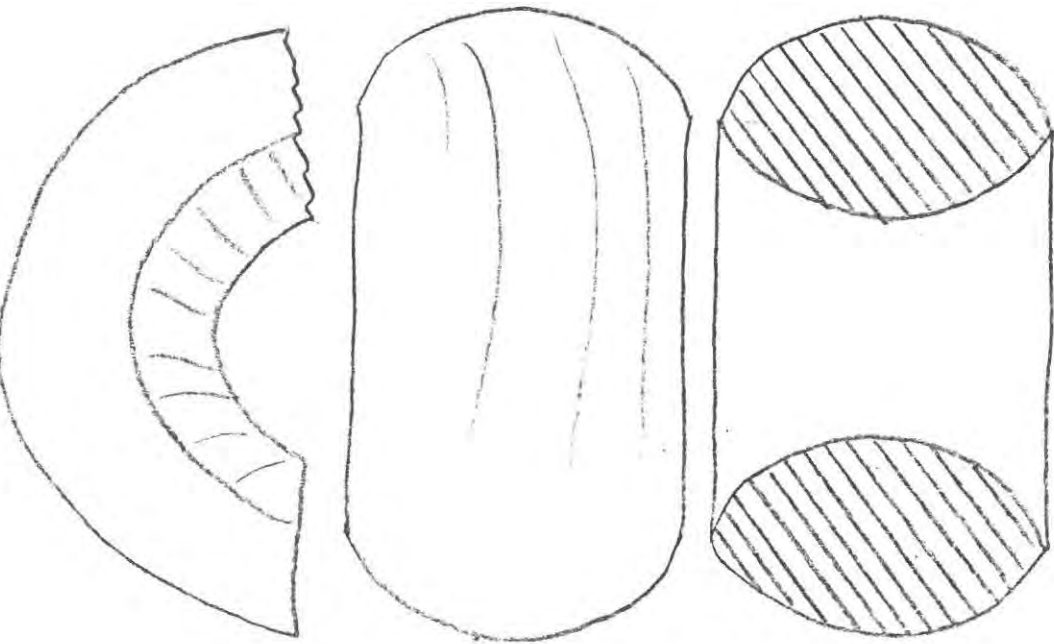

TYPE #2 DIGGING WEIGHT

Fig. 25

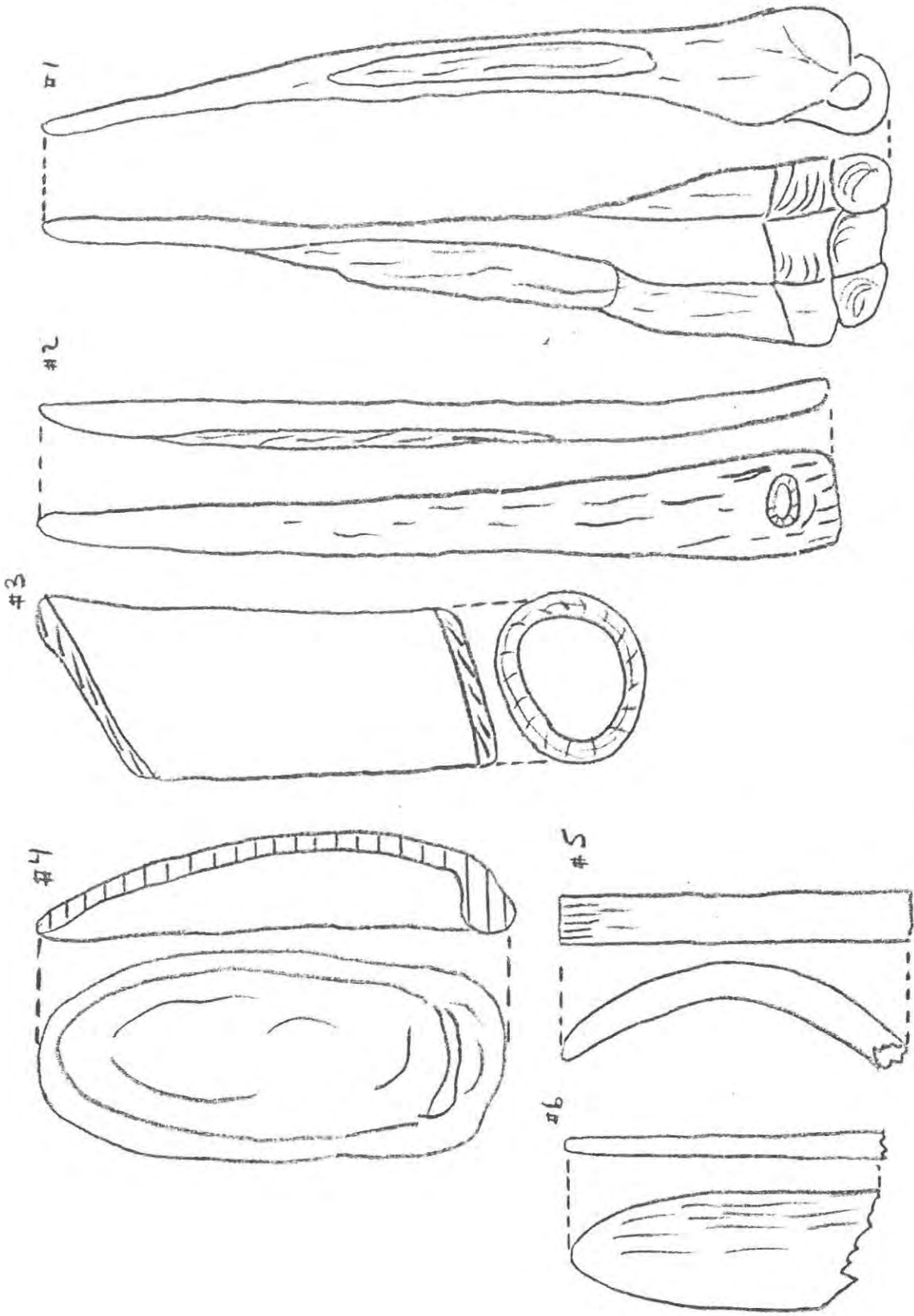

CALPISH : PJUM 618-10-4

Fig. 26

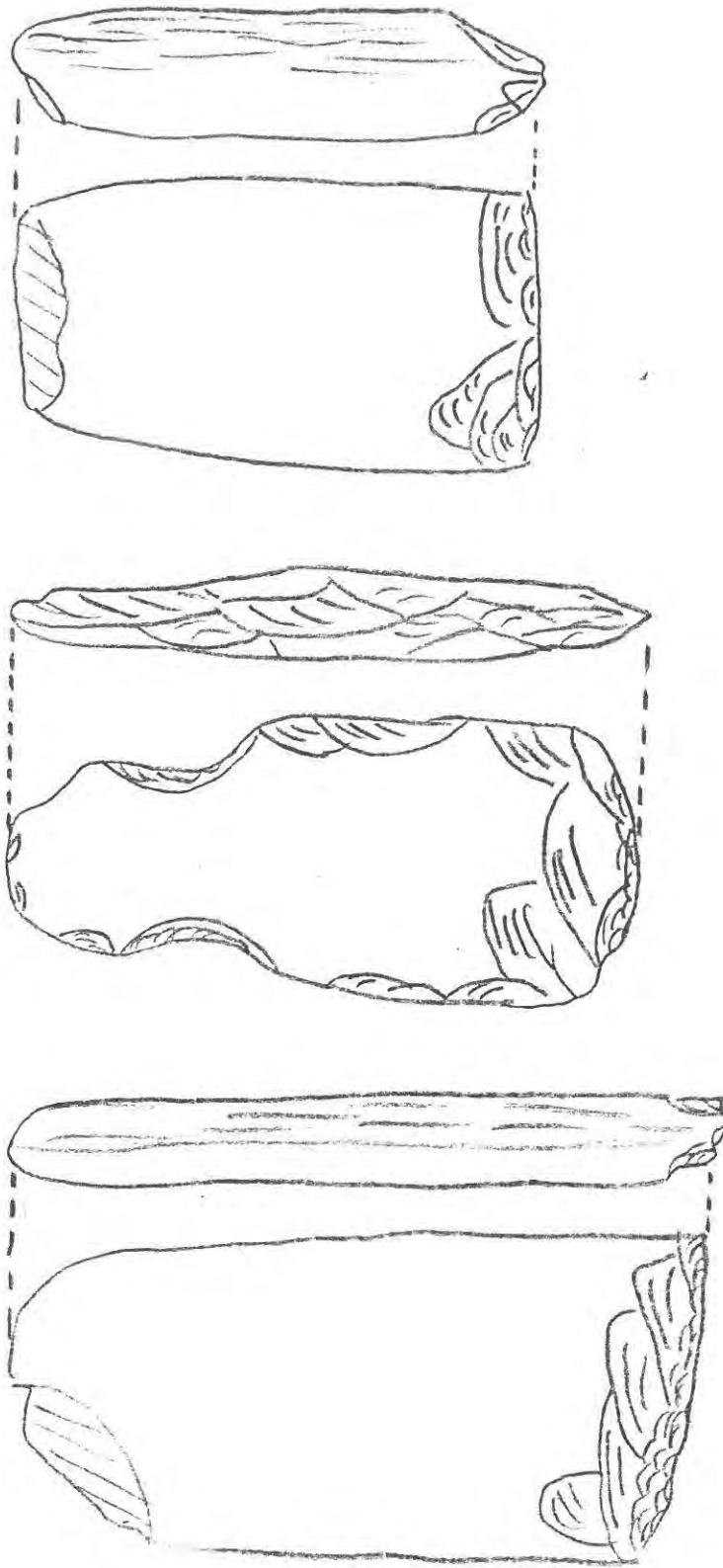

CALPISH

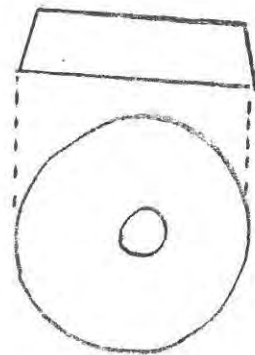
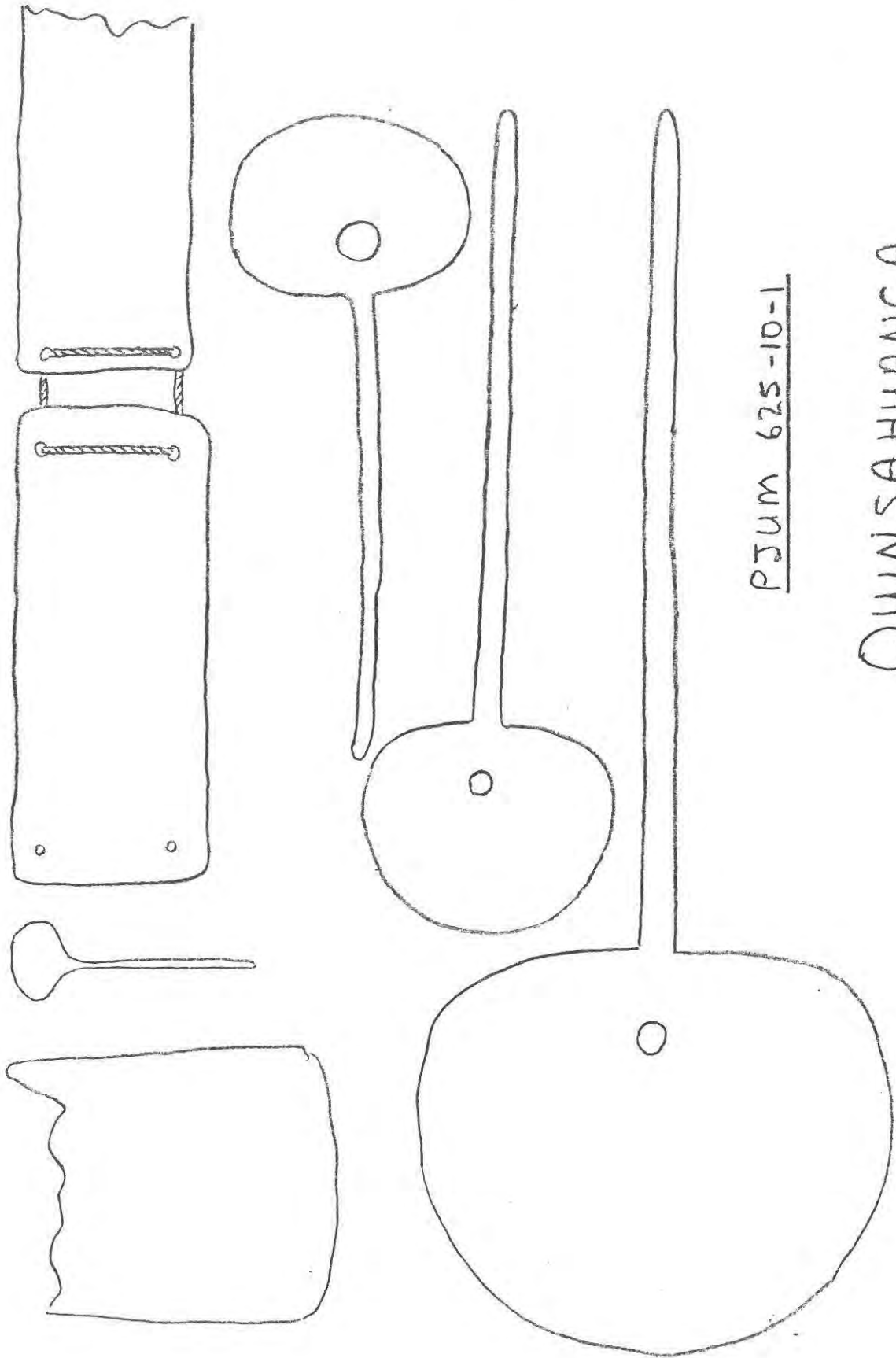

Fig. 27



PJUM 625-10-1

QUINSAHUANCA

Fig. 28

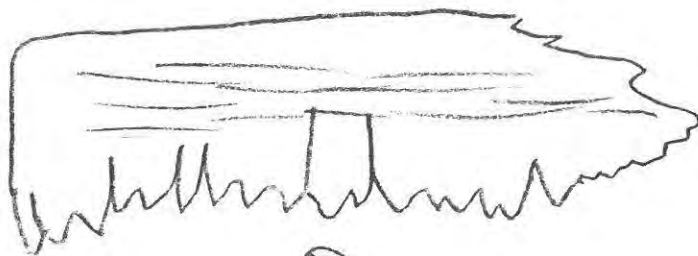
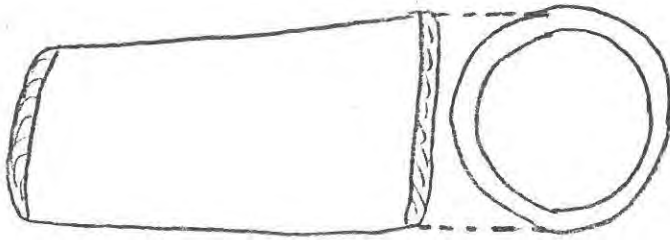
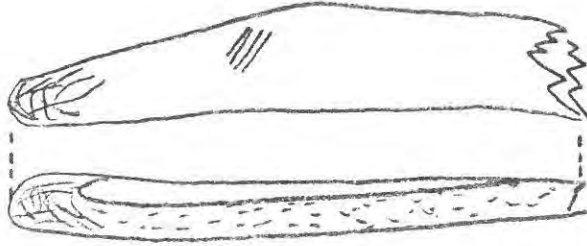

ARHUATURO

Fig. 29

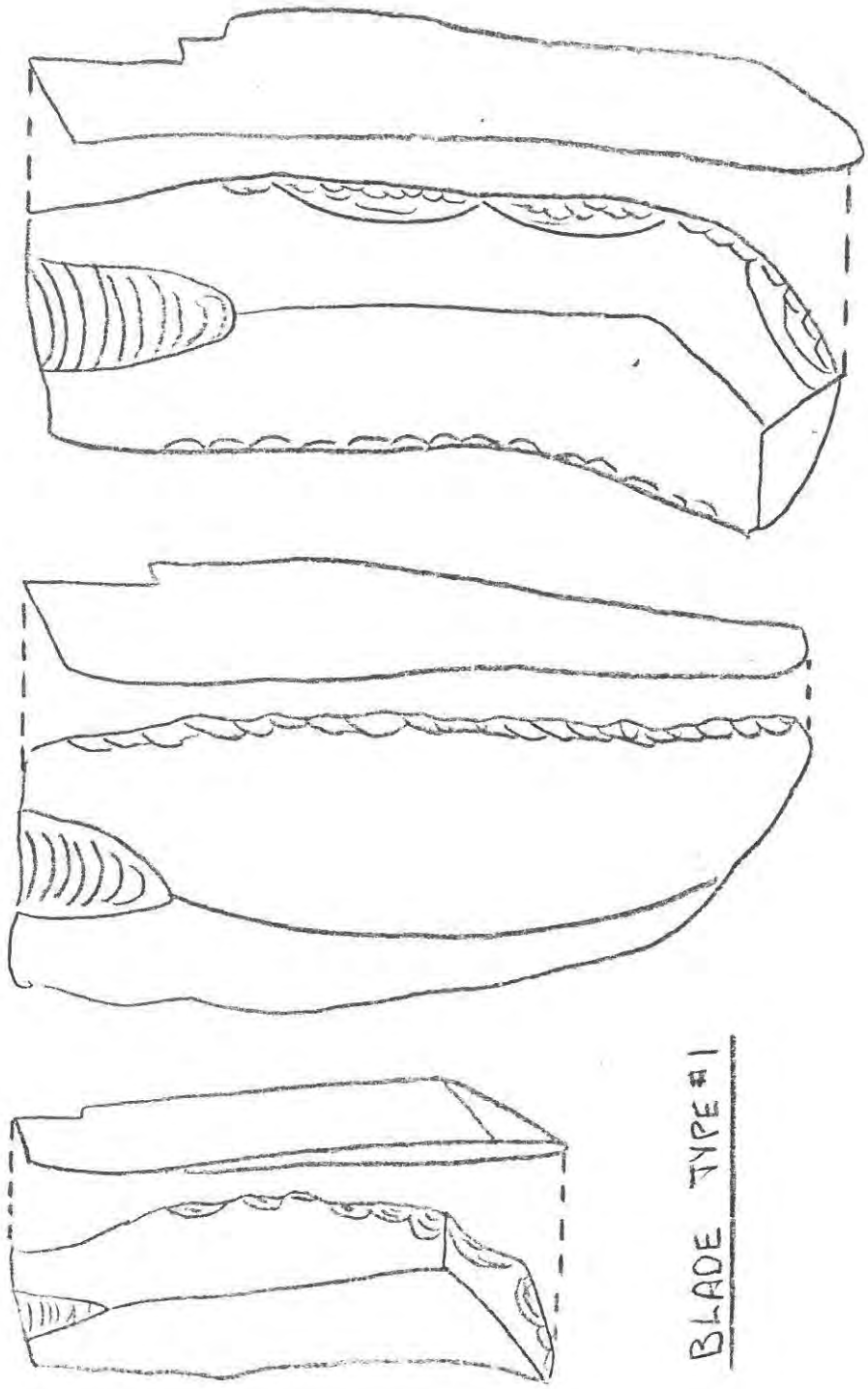

BLADE TYPE #1

MATA PUQUIO, ARHUATURO, ARHUATURO -INCA

Fig. 30

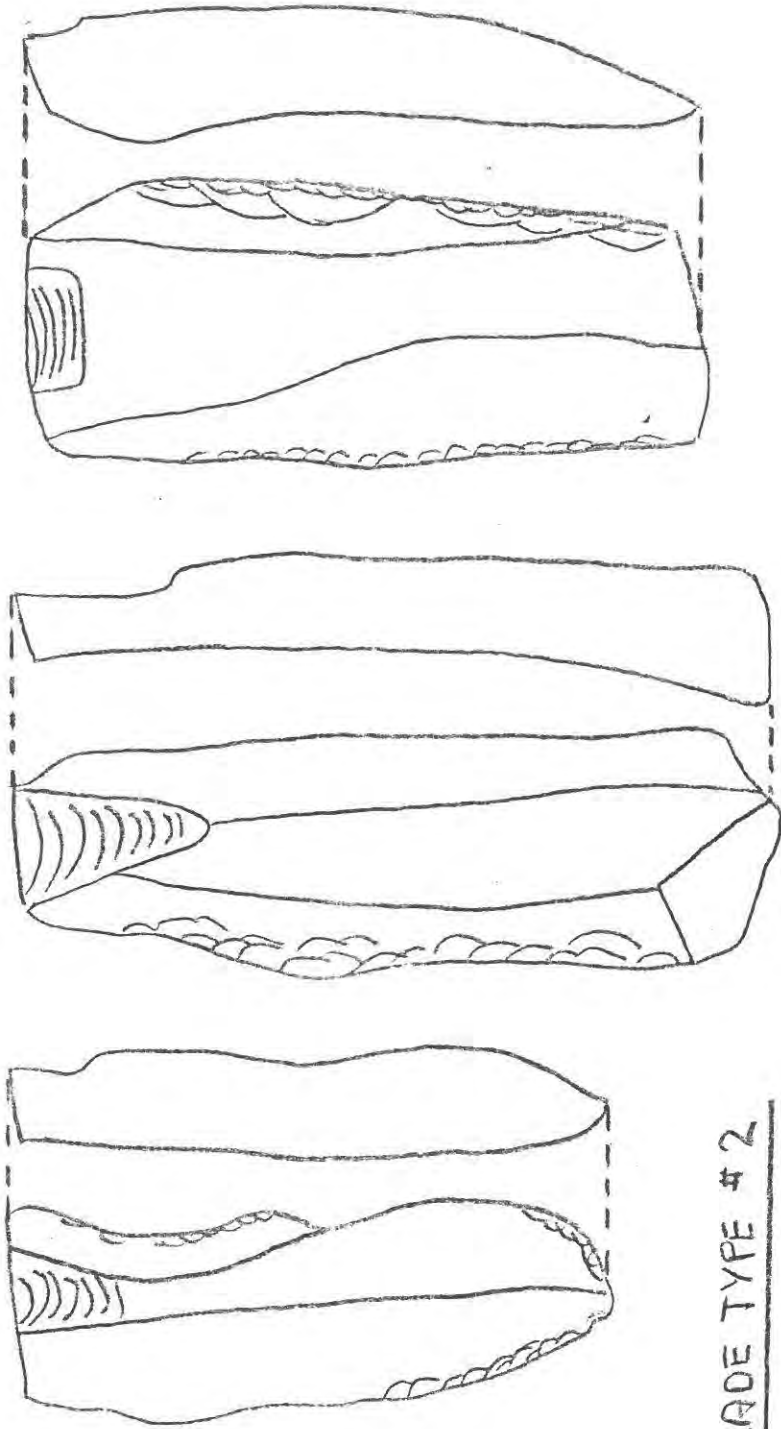

BLADE TYPE #2

MATAPUQUIO, ARHUATURO, ARHUATURO, INCA

Fig. 31

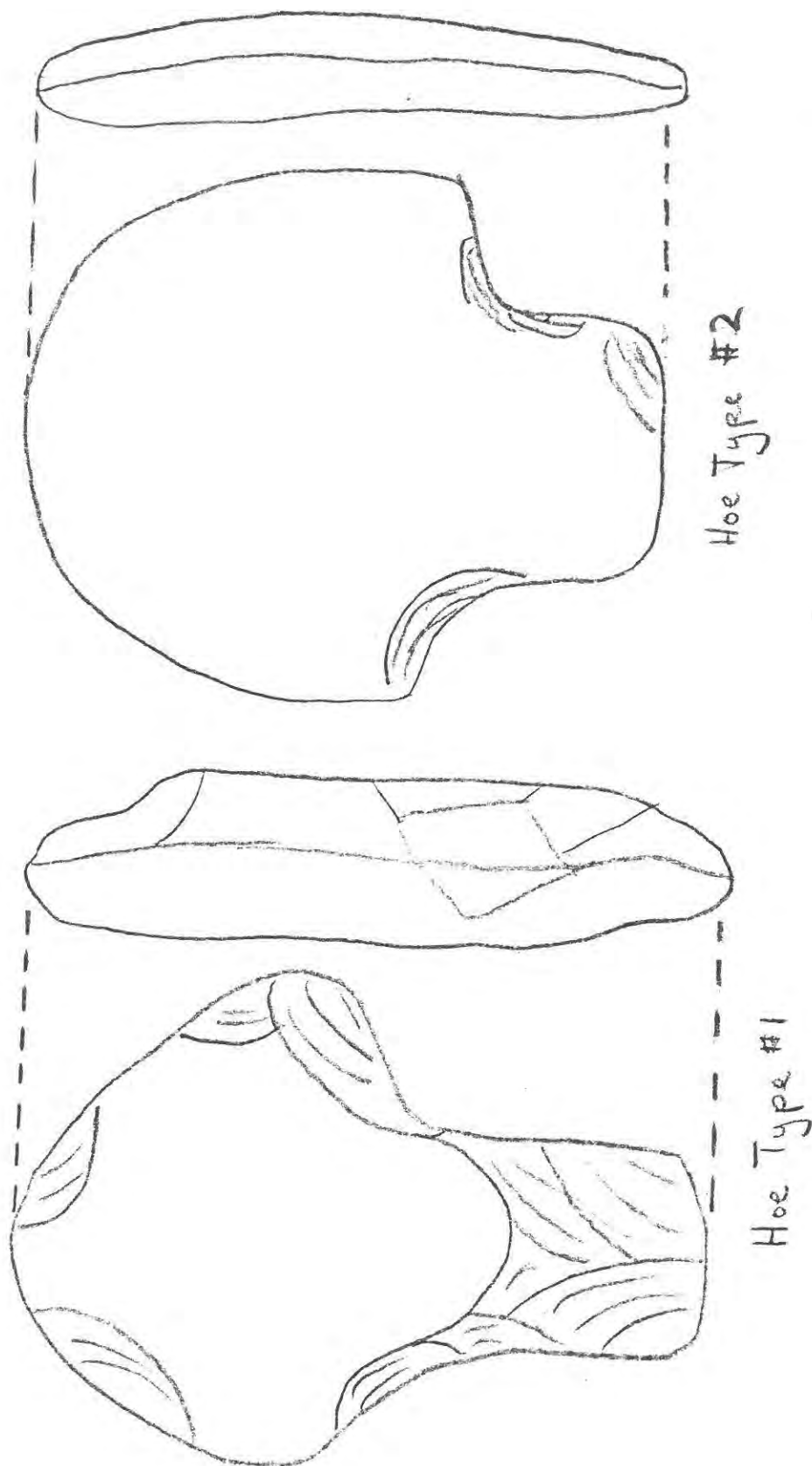

CALPISH, QUINSAHUANCA, MATAPUQUIO

Fig. 32

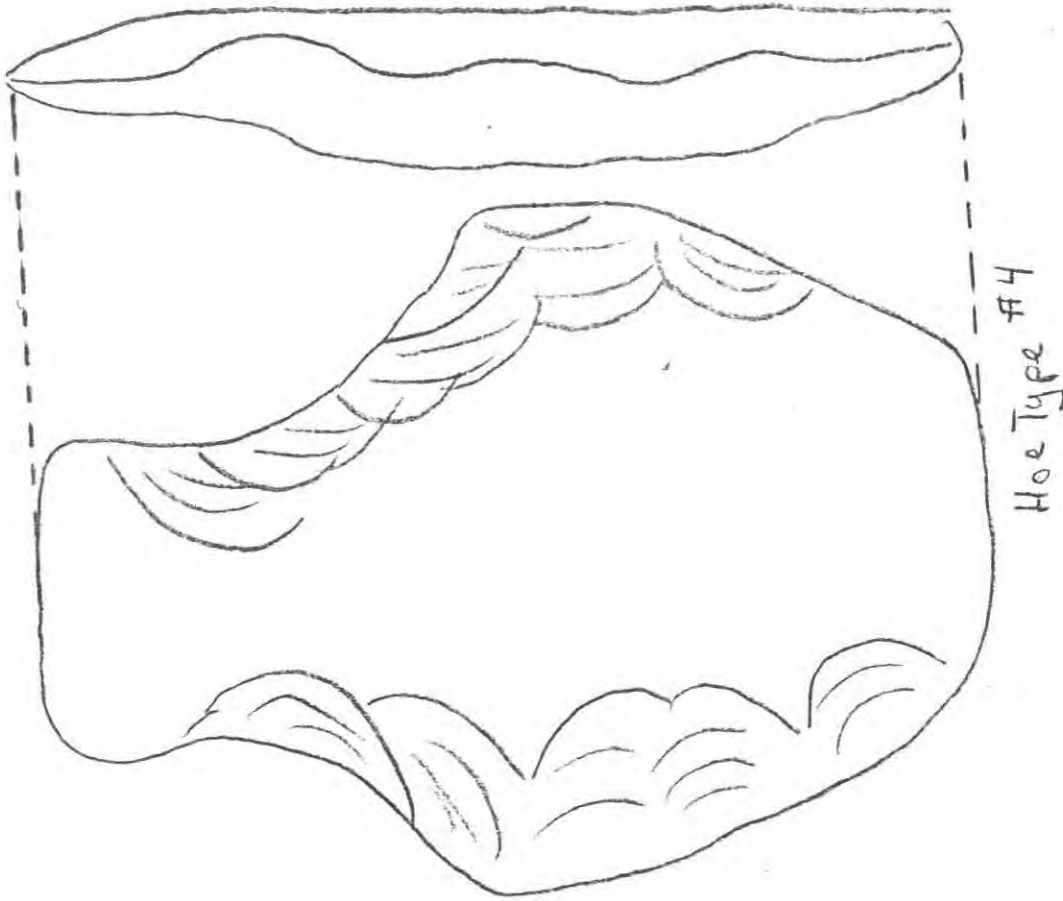

Hoe Type #4

ARHUATURO, INCA

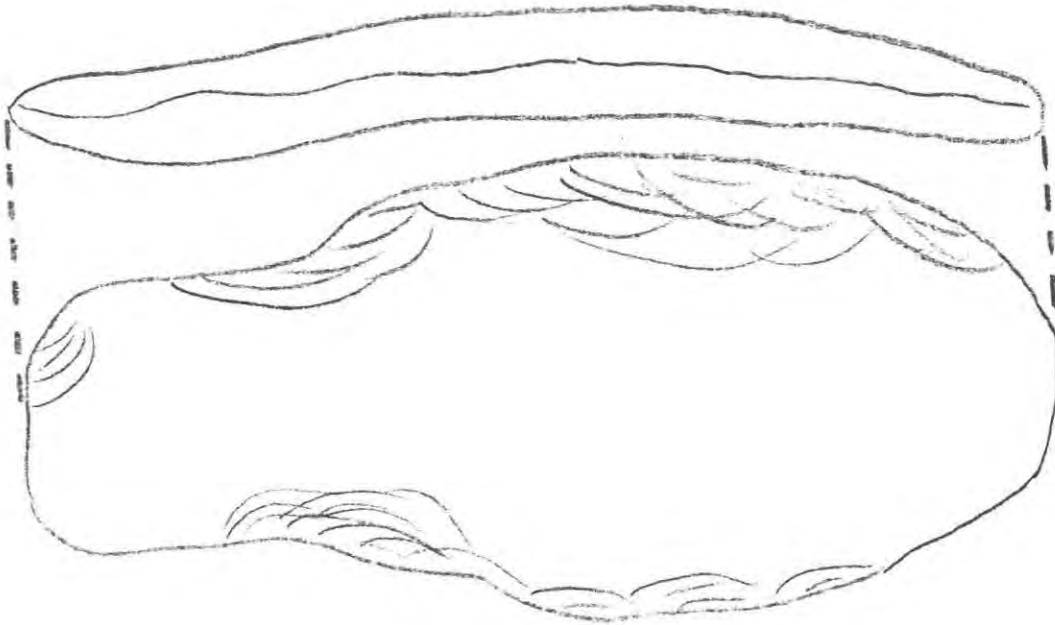

Hoe Type #3

Fig. 33

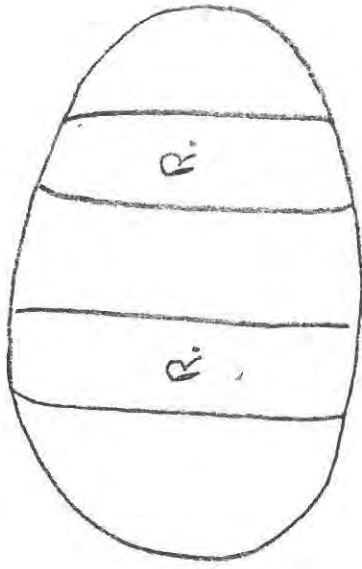
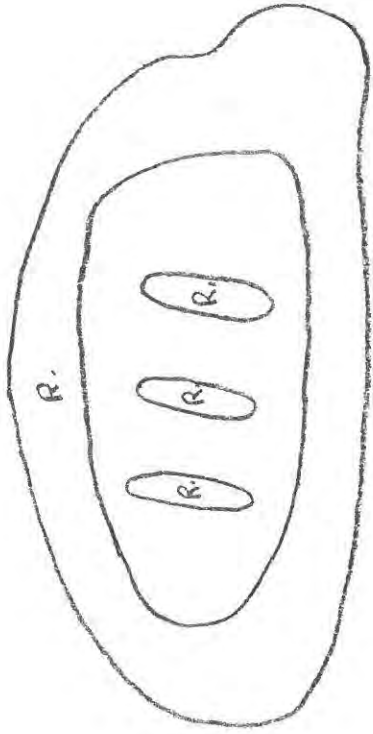

PAINTED PEBBLES

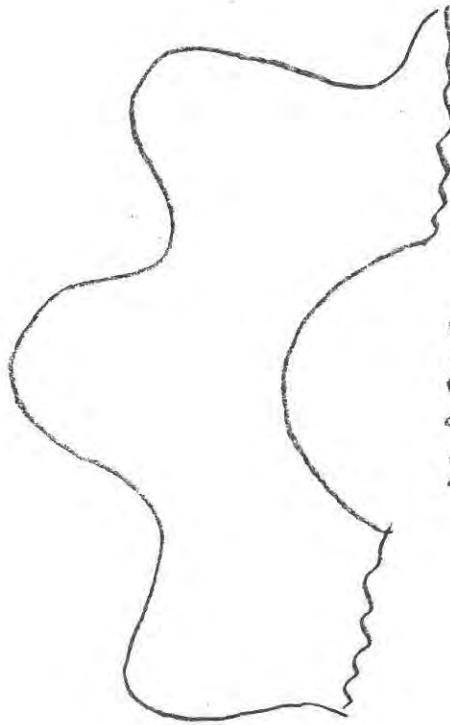
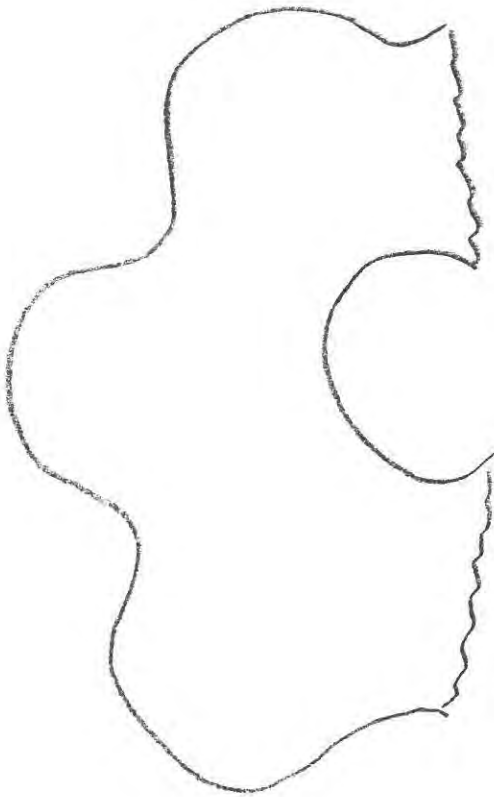

MACES

INCA

Fig. 34

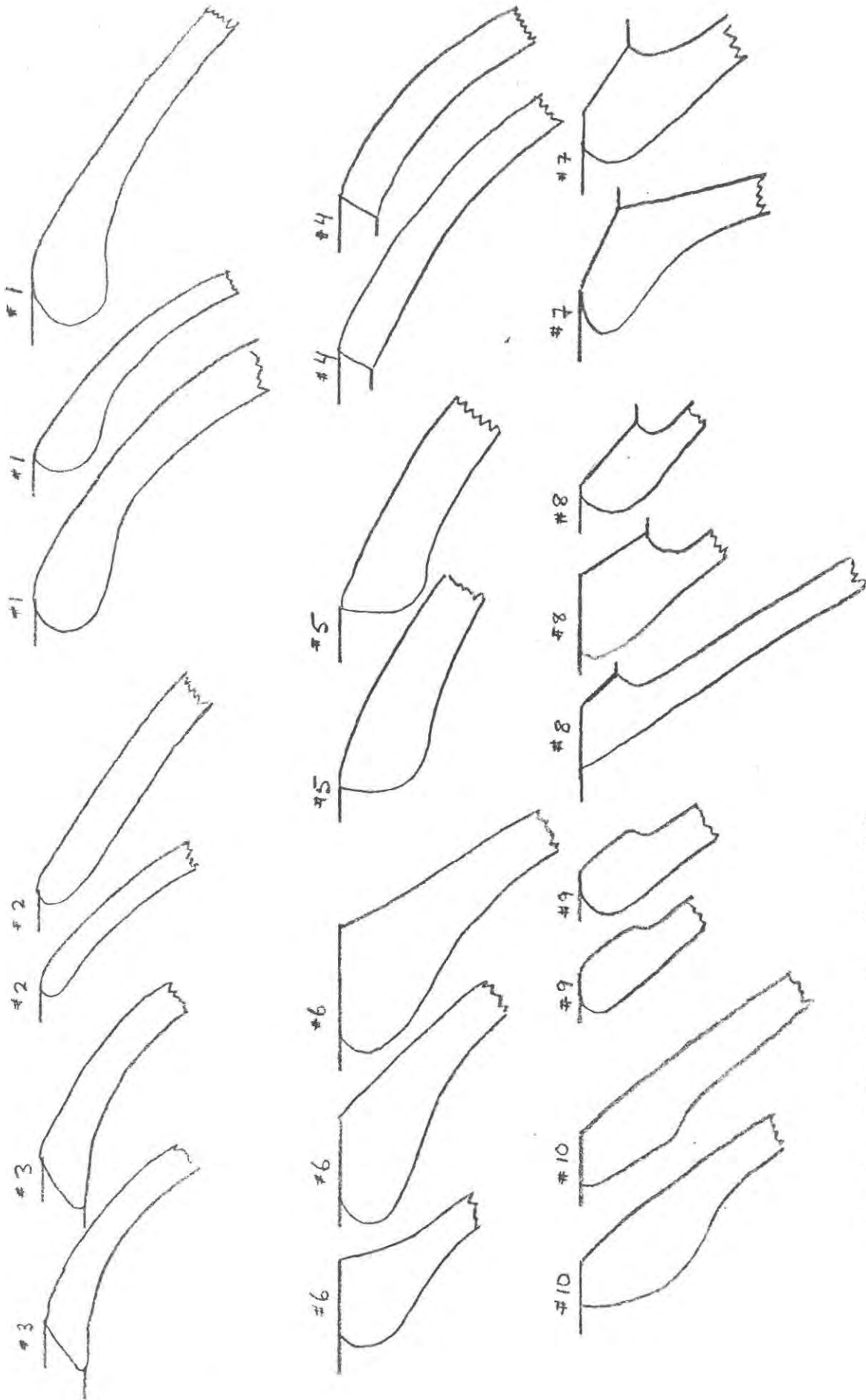

PIRWAPUQUIO OLLAS

Fig. 35

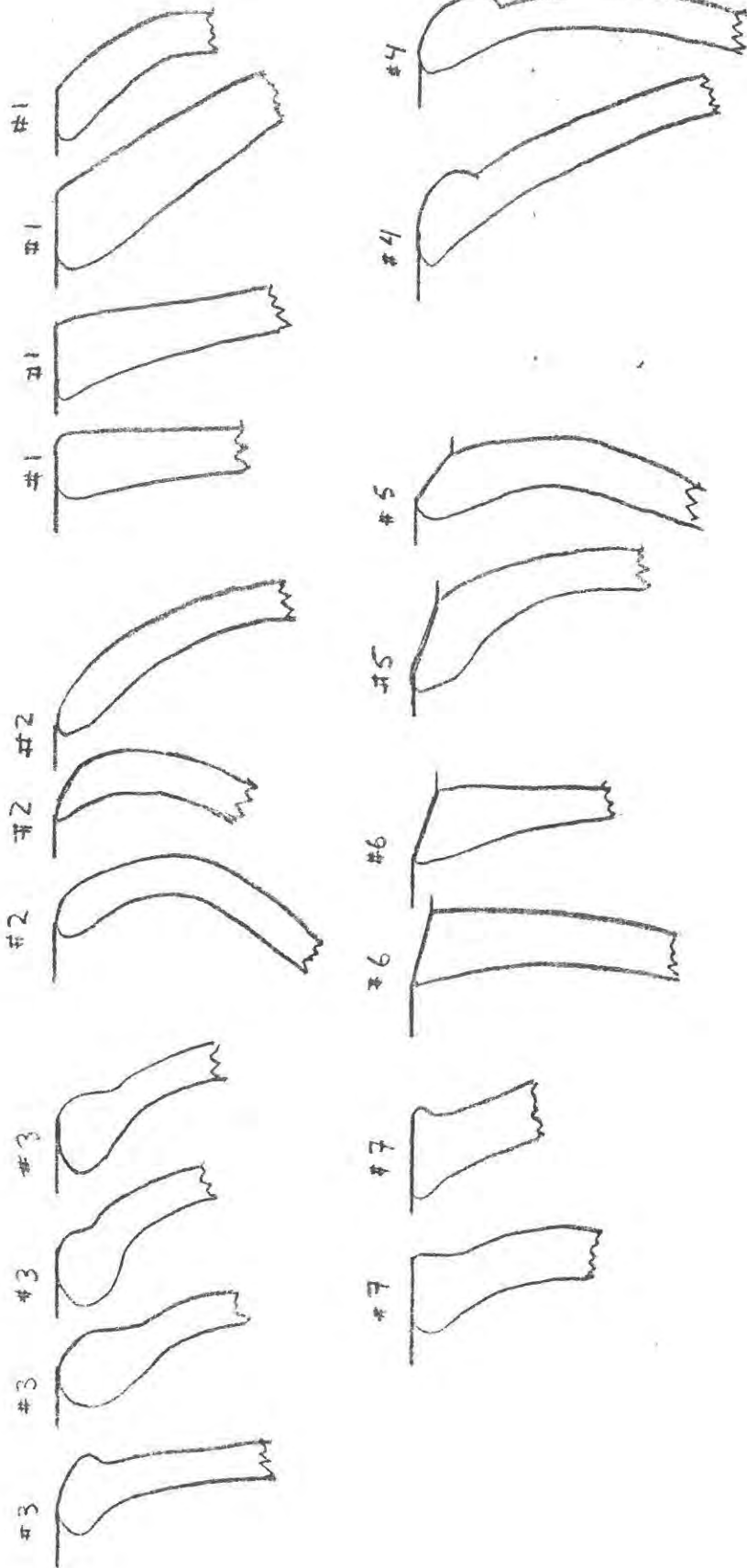

PIRWAPUQWIO ENCLOSED BOWLS

Fig. 36

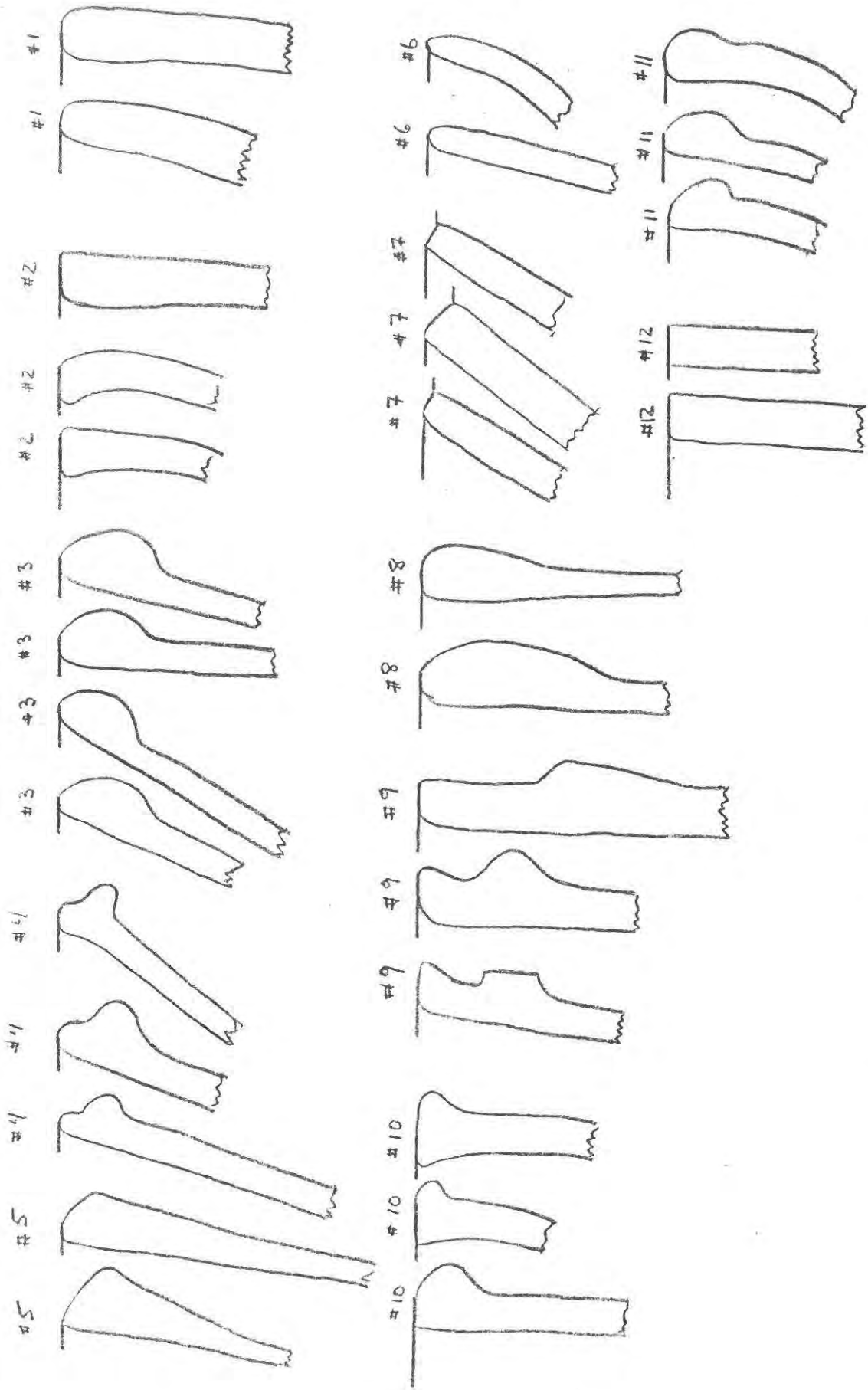

PIRWAPUQUIO OPEN BOWLS

Fig. 37

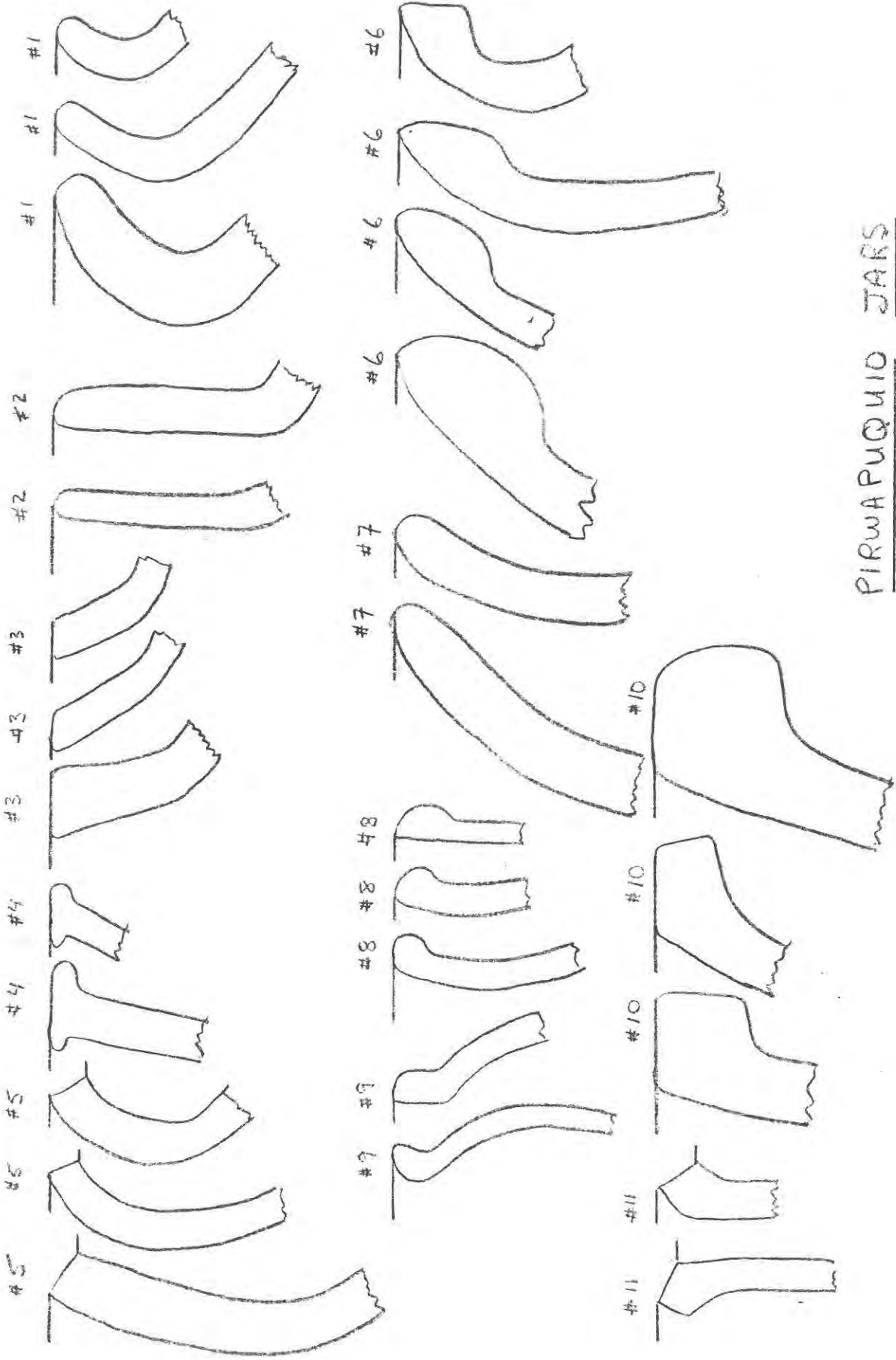

PIRWAPUQUIO JARS

Fig. 38

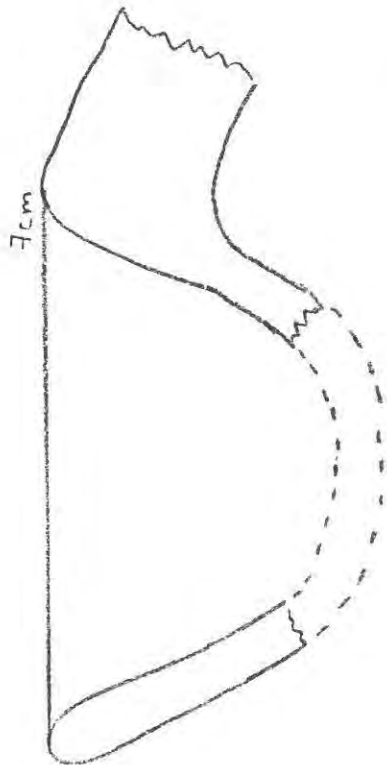
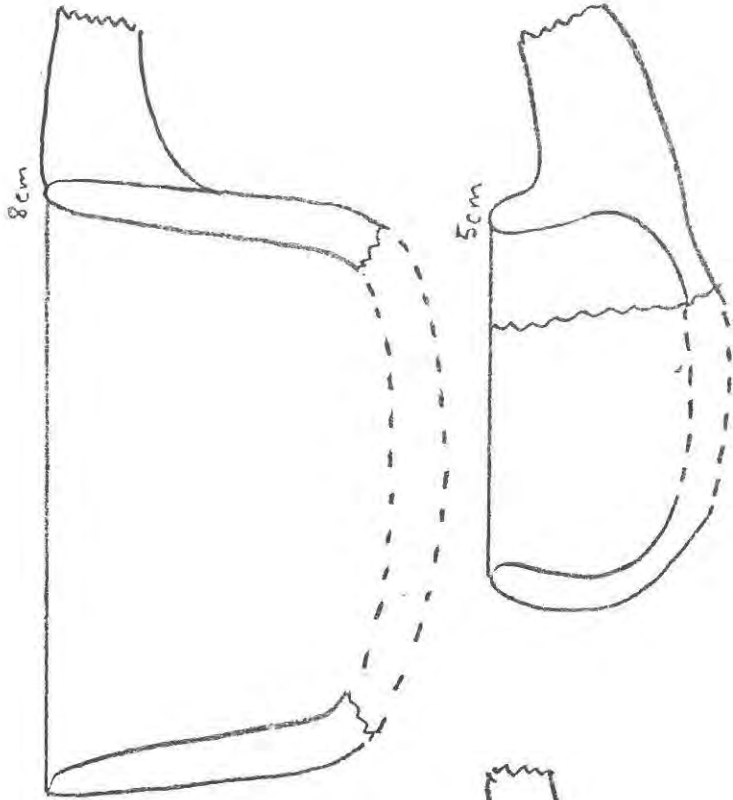

SPOONS AND LADLES



PLATES OR LIDS

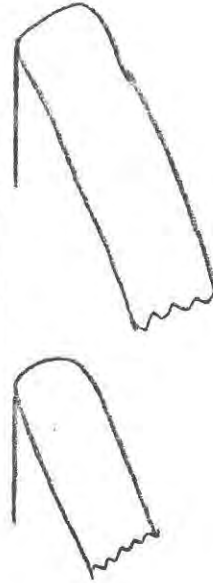

MISCELLANEOUS PIRWAPUQUIO

BOTTLE SPOUTS

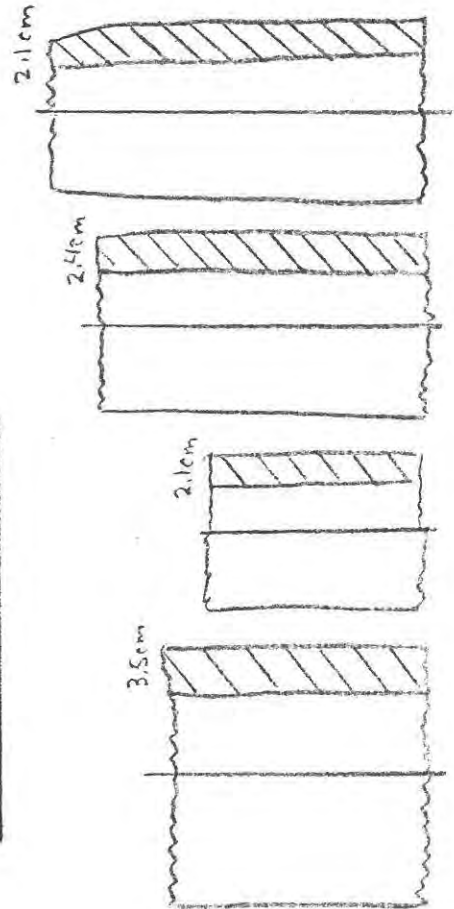
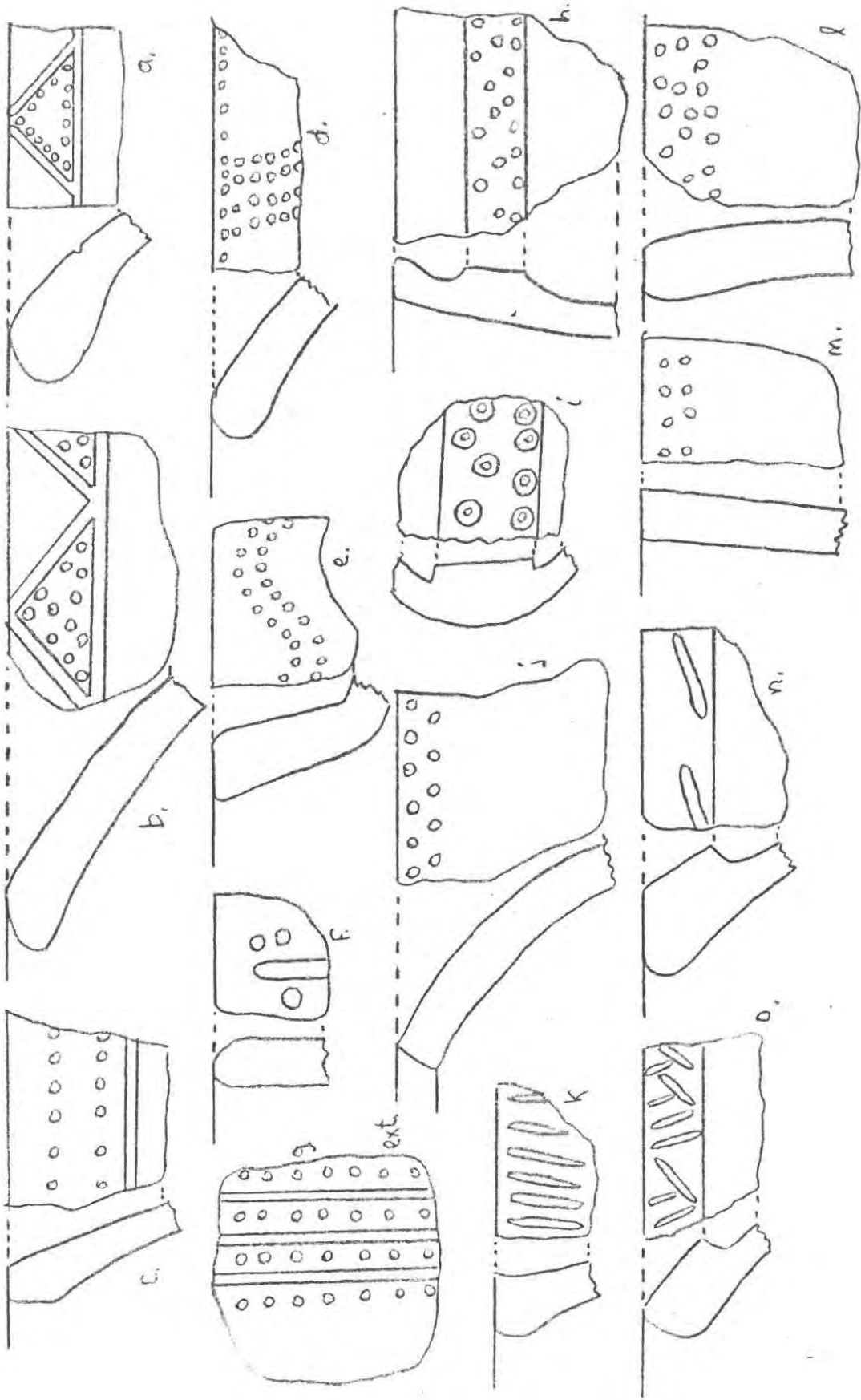
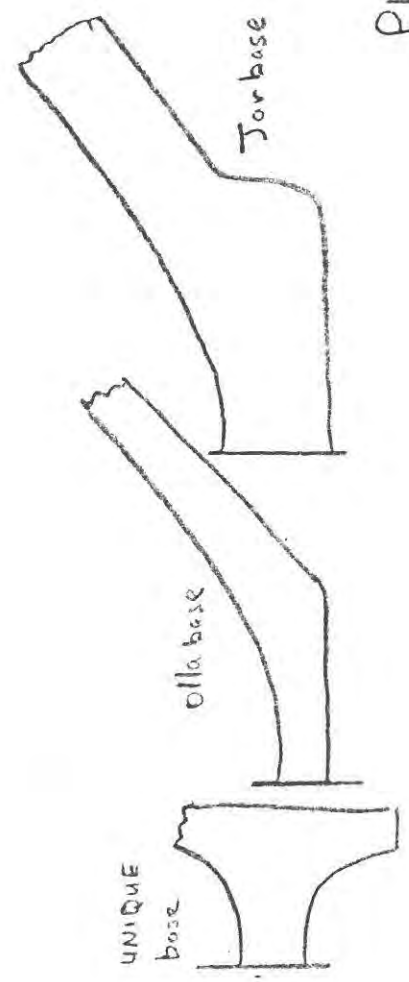
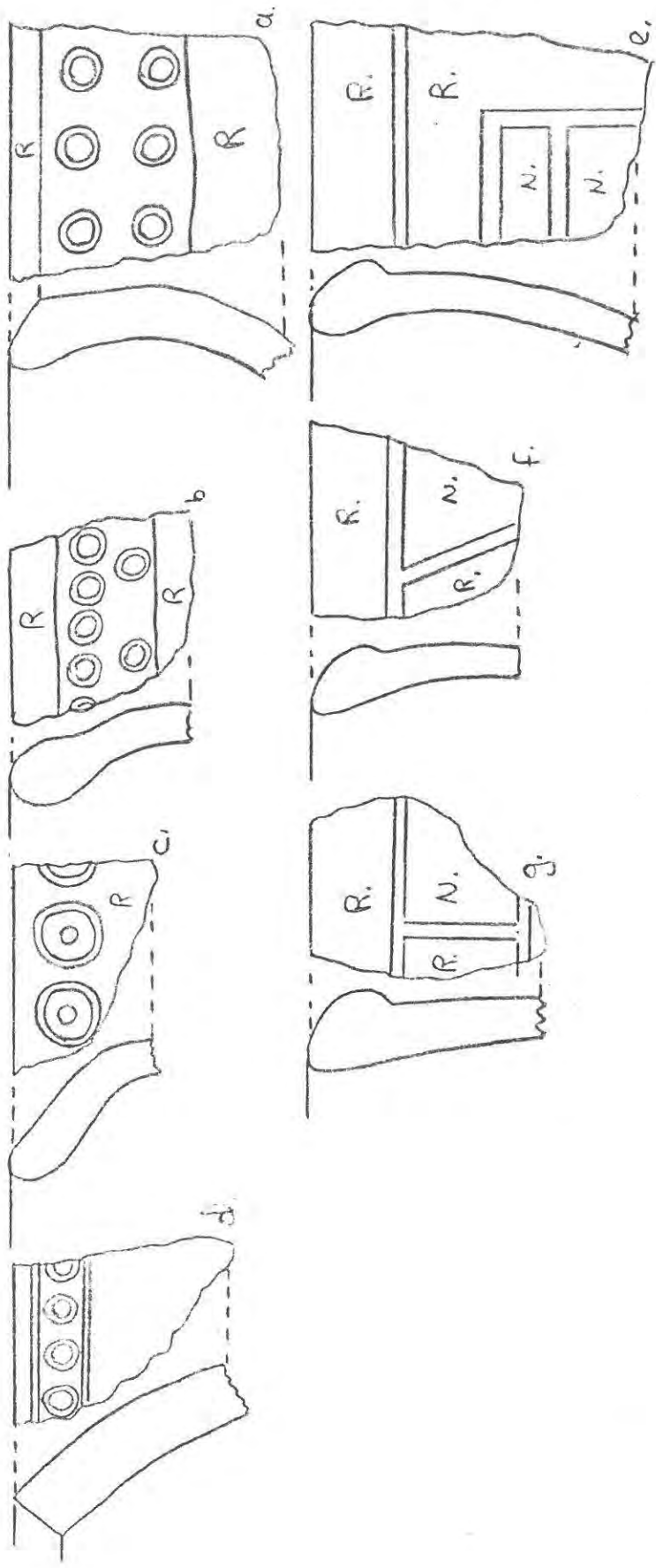

Fig. 39



PIRWAPUQUIO A

Fig. 40



PIRWA PUQUIO A

Fig. 41

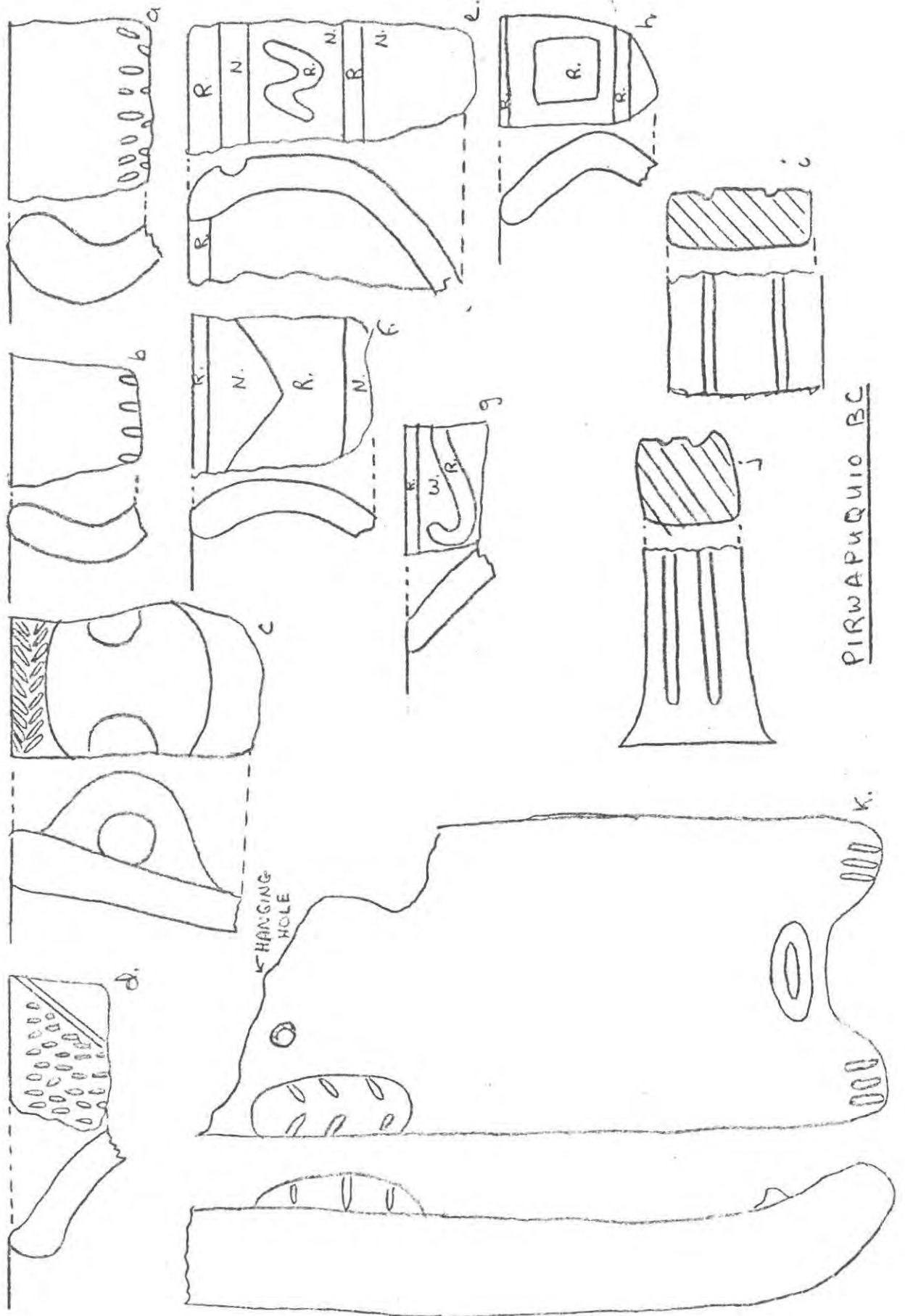

PIRWAPUQUIO BC

Fig. 42

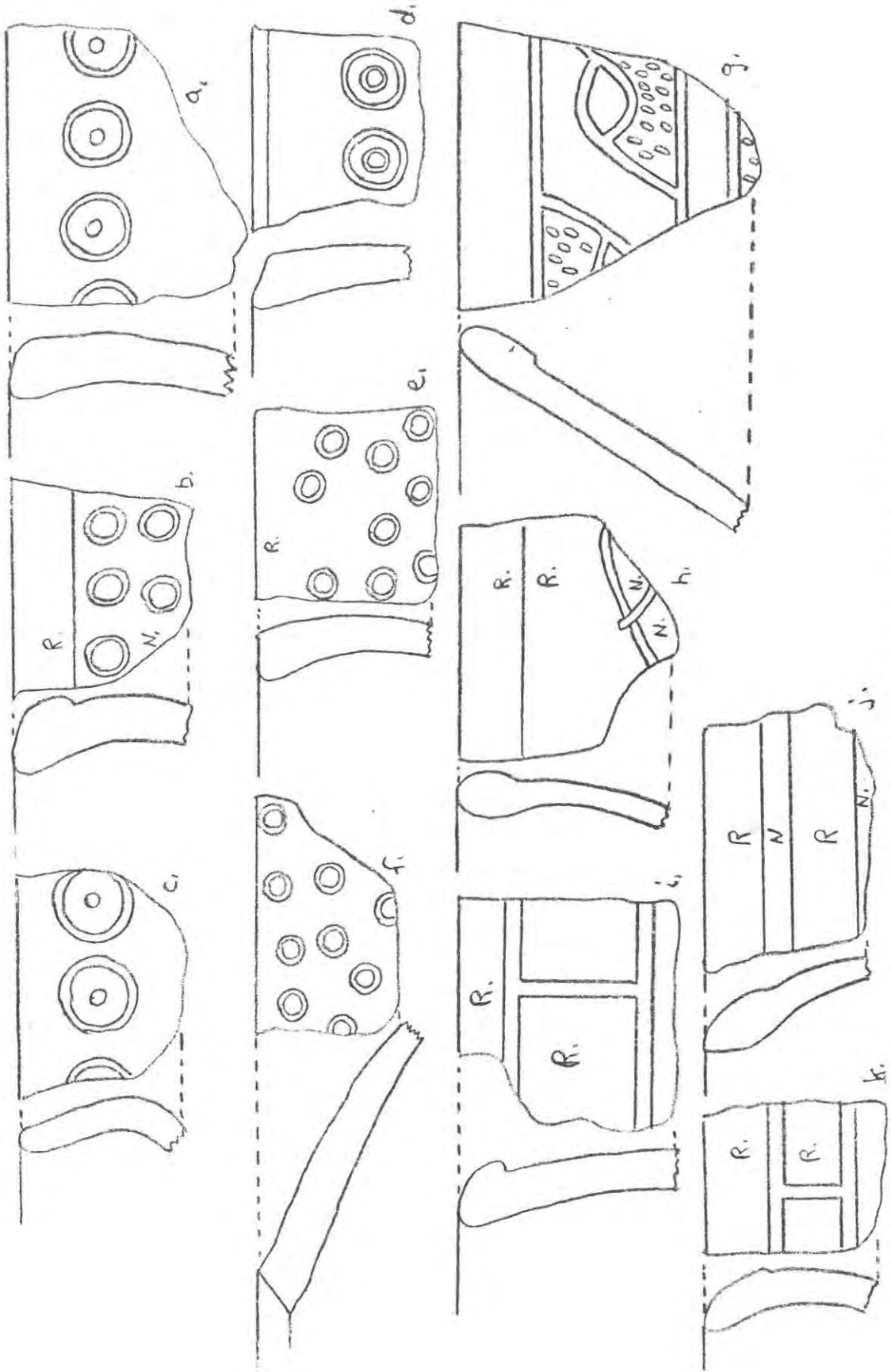

PIRWA PUQUIO DEF

Fig. 43

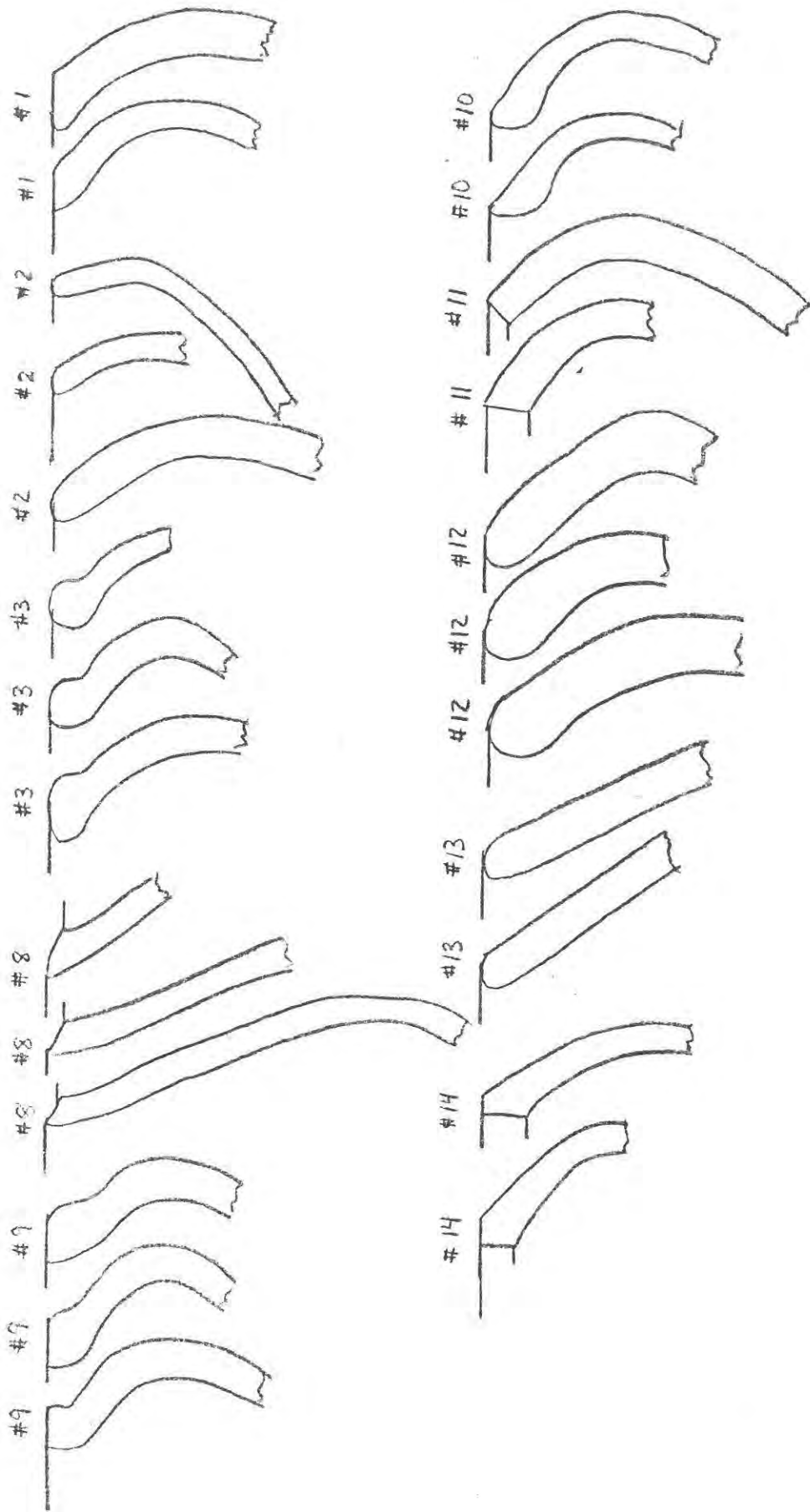

COCHA CHONGOS ENCLOSED BOWLS

Fig. 44

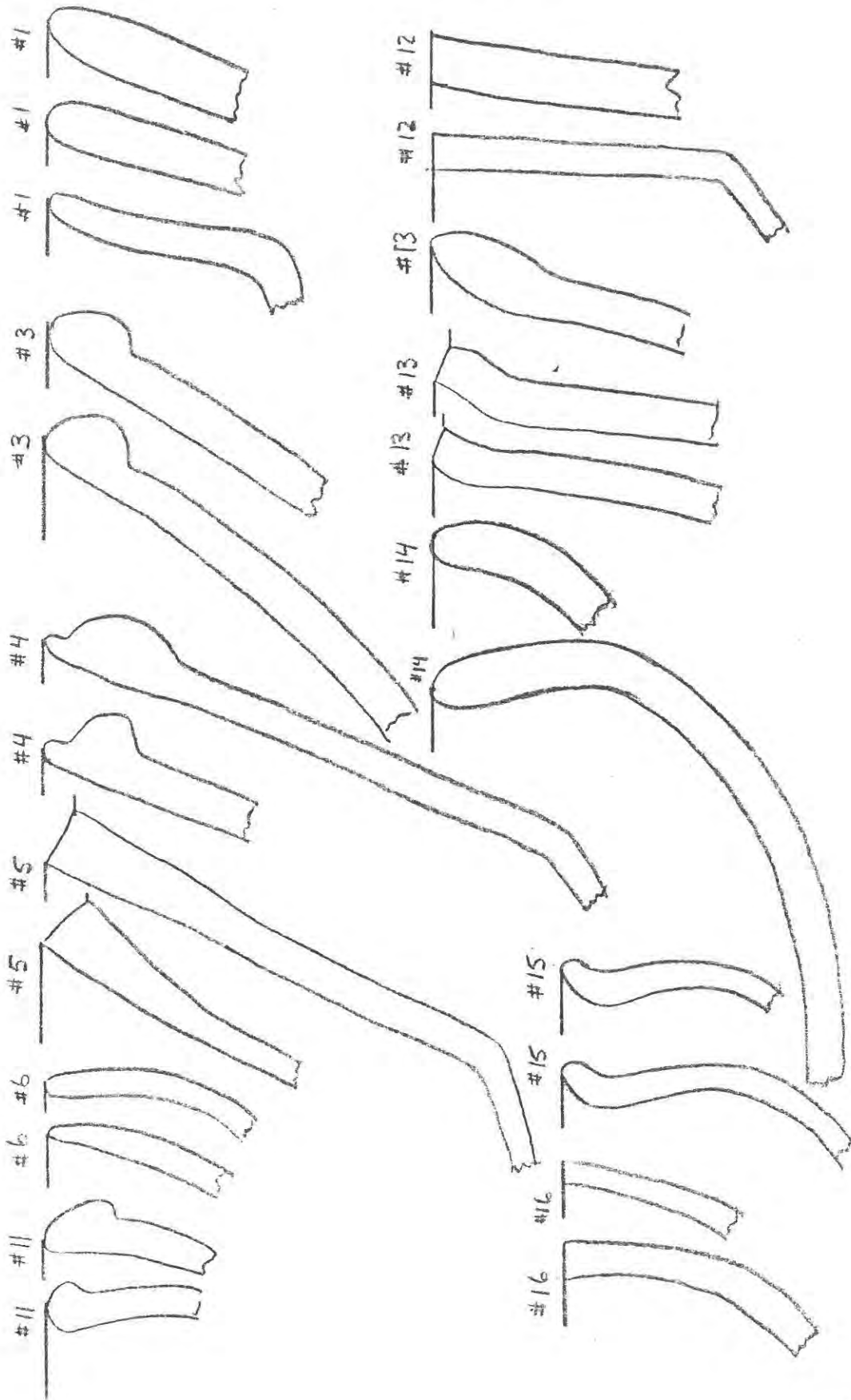

COCHACHONGOS OPEN BOWLS

Fig. 45

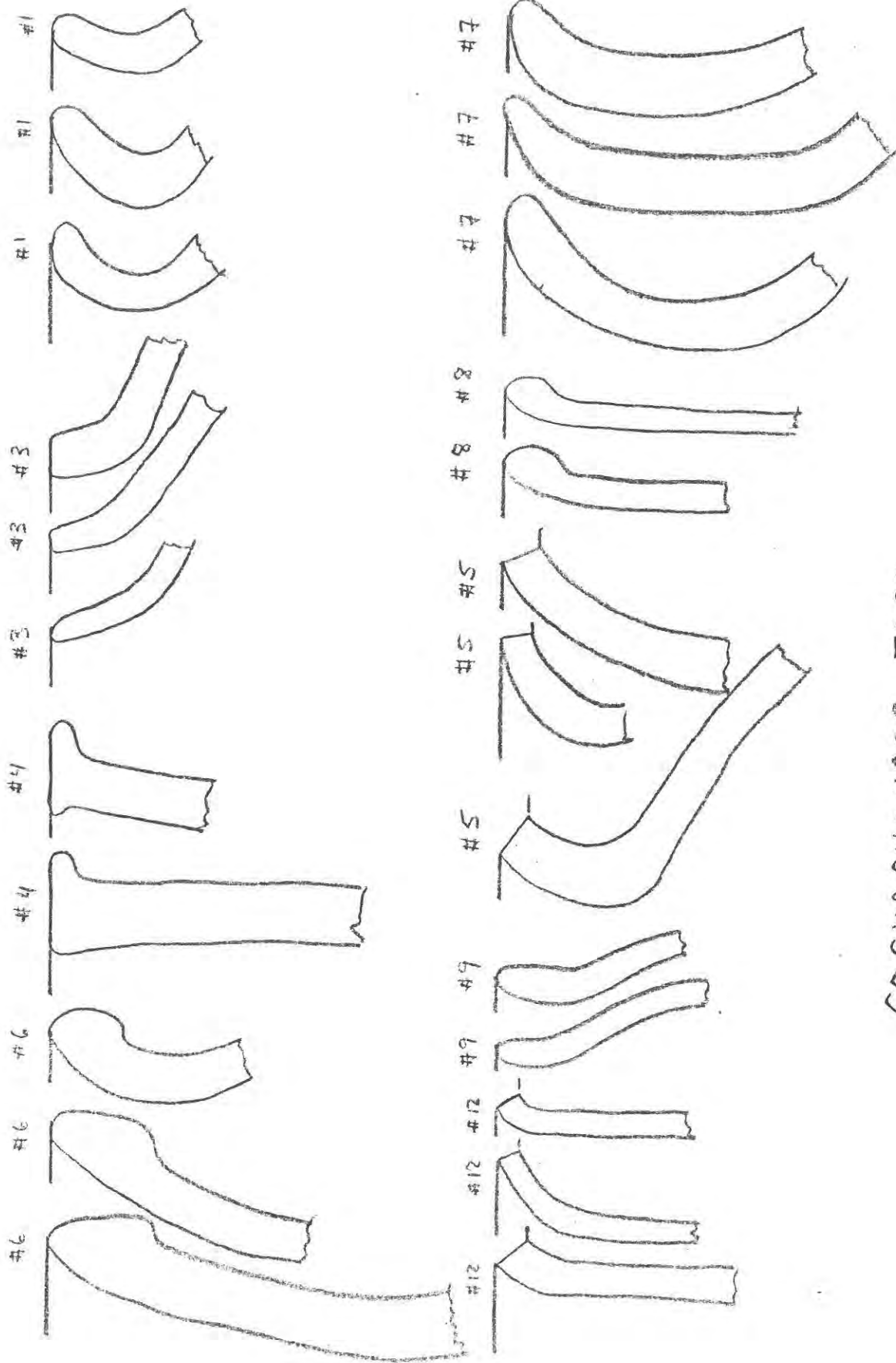

COCHACHONGOS JARS

Fig. 46

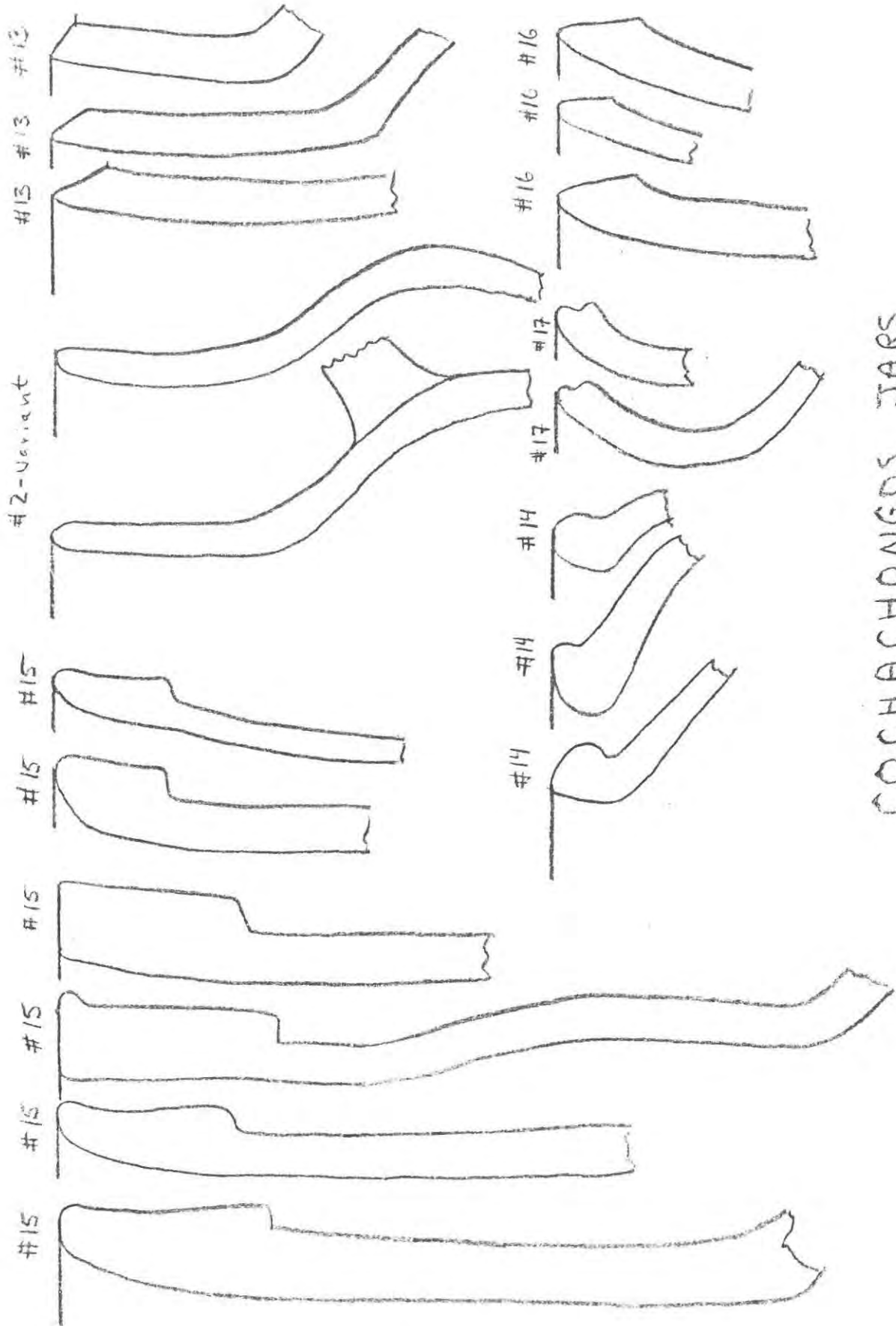

COCHACHONGOS JARS

BOTTLES

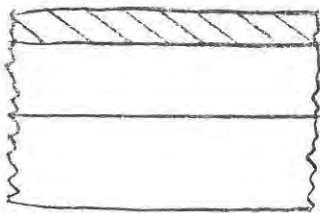

OLLAS

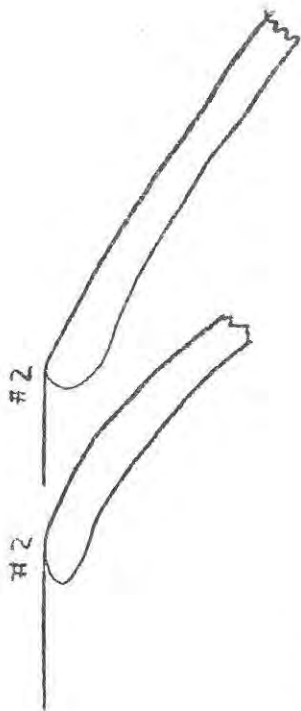

LIDS

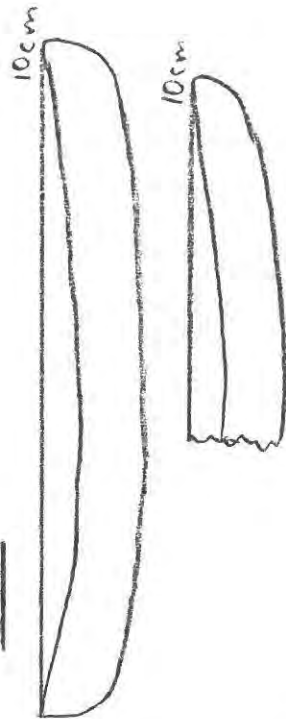
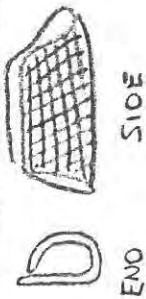
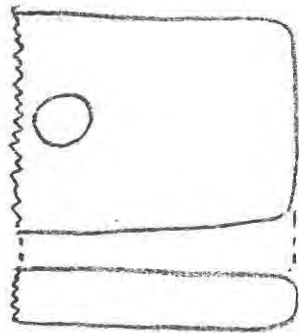

Fig. 47

TEXTILE-IMPRESSED CERAMIC BEAD



CERAMIC PENDANT



COCHACHONGOS - VARIOUS

Fig. 48

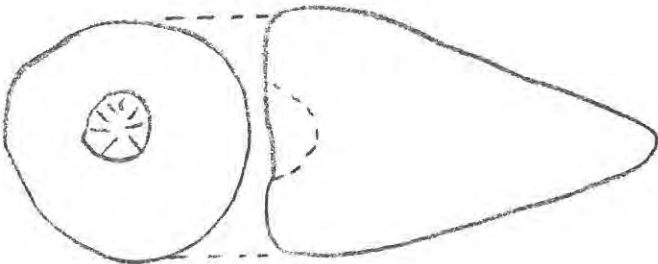
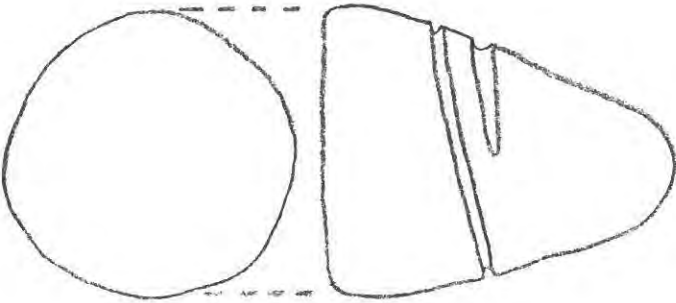
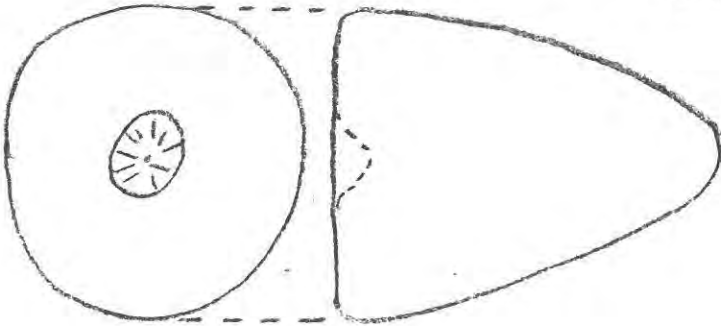
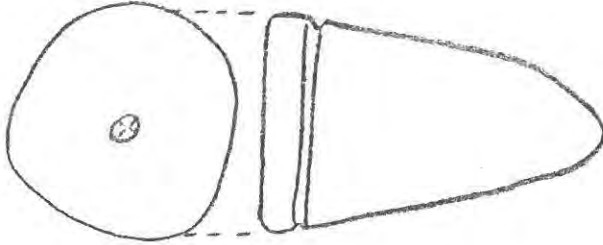
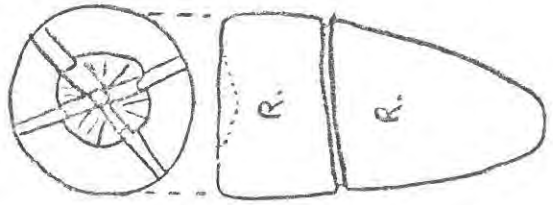

CONICAL CERAMIC TOPS

GEOMETRICS

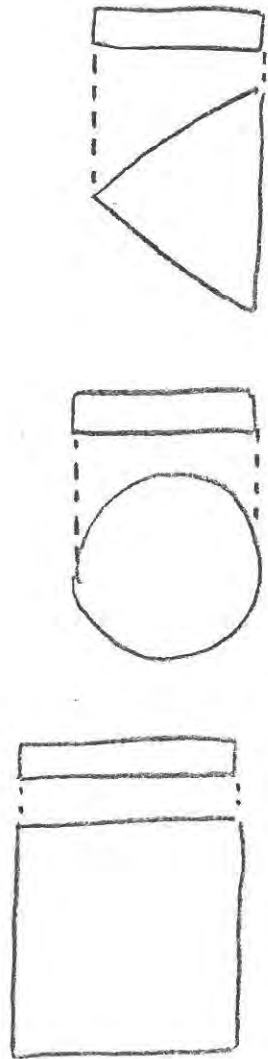

COCHA CHONGOS

Fig. 49

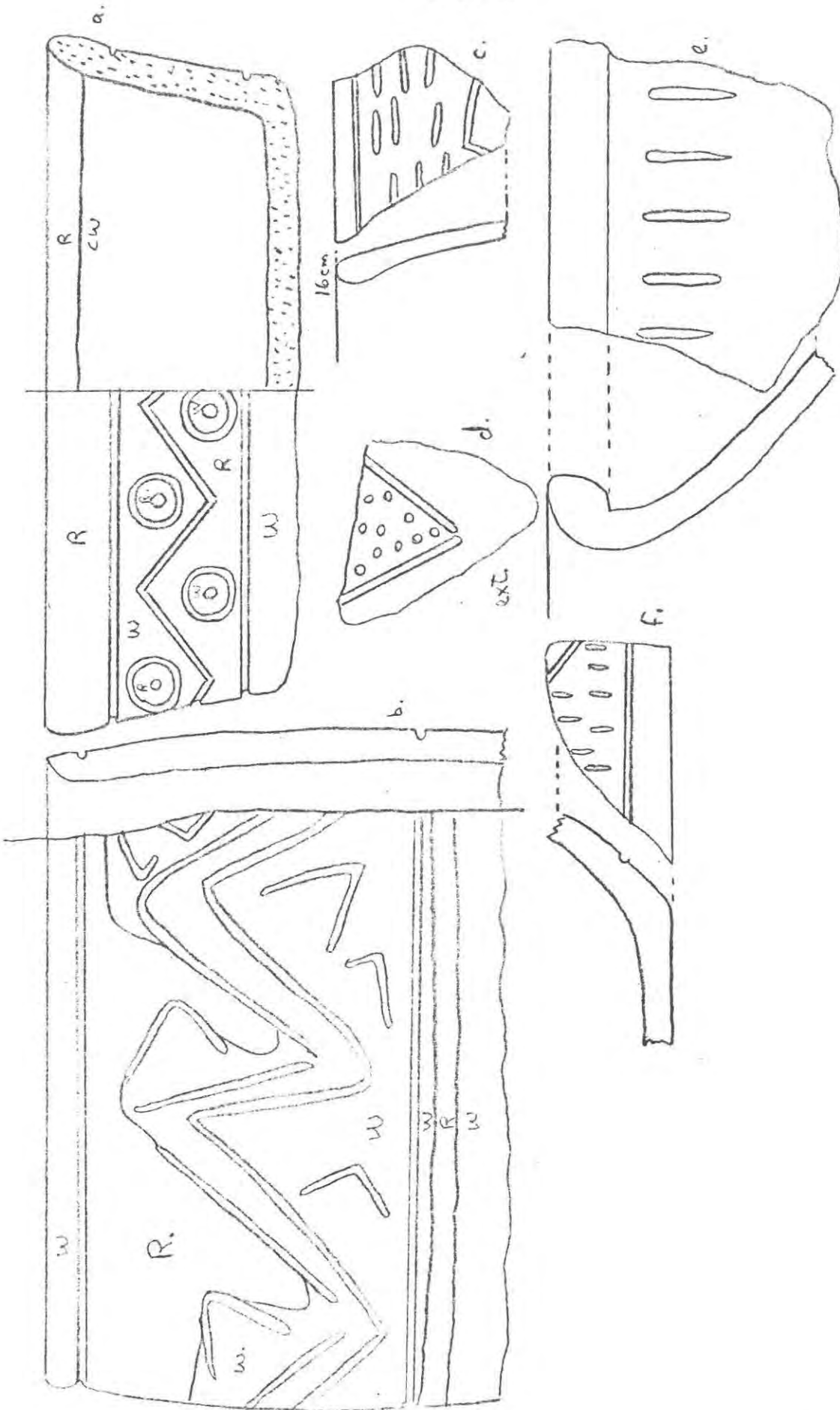

COCHACHONGOS AB

Fig. 50

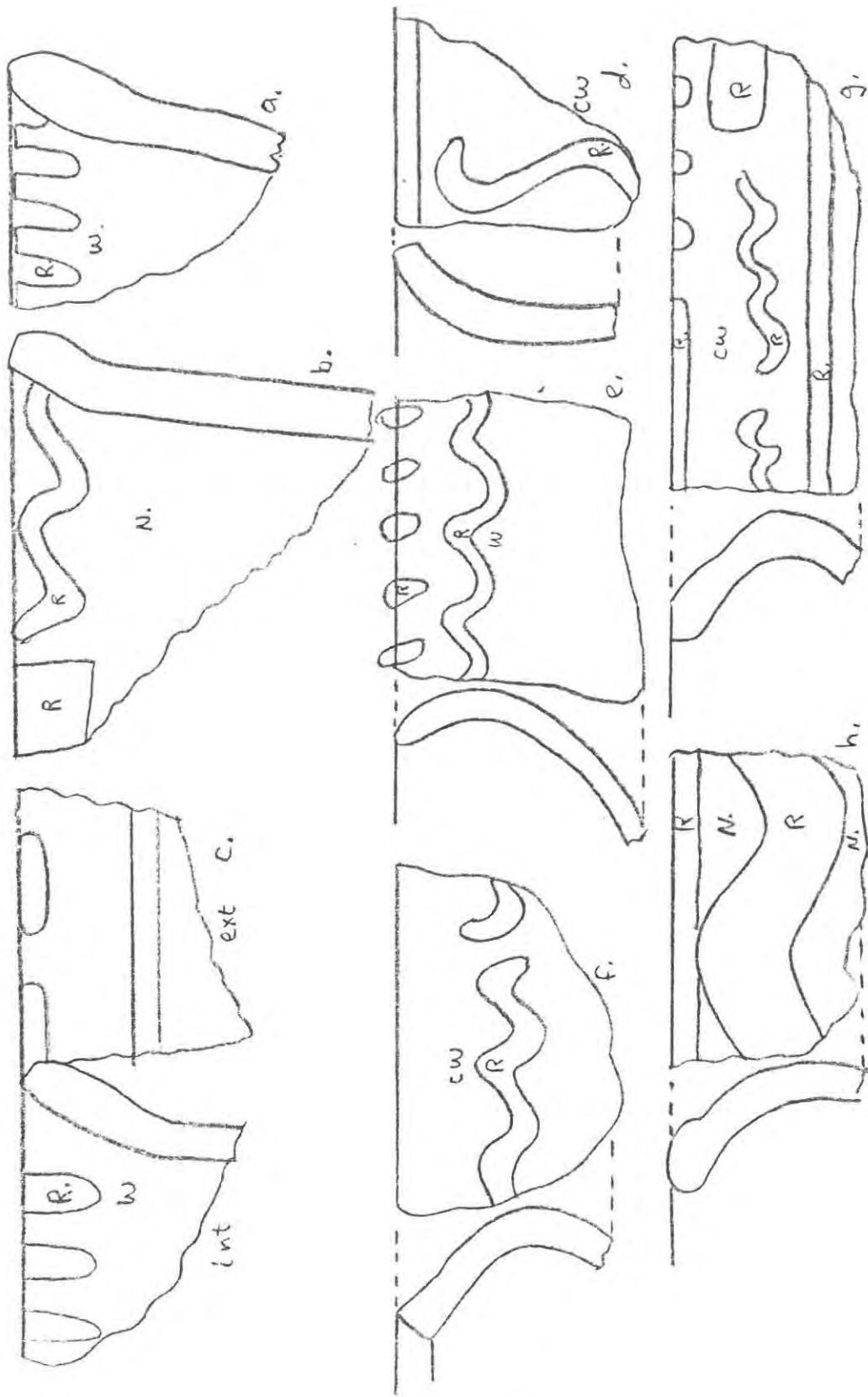

COCHACHONGOS AB

Fig. 51

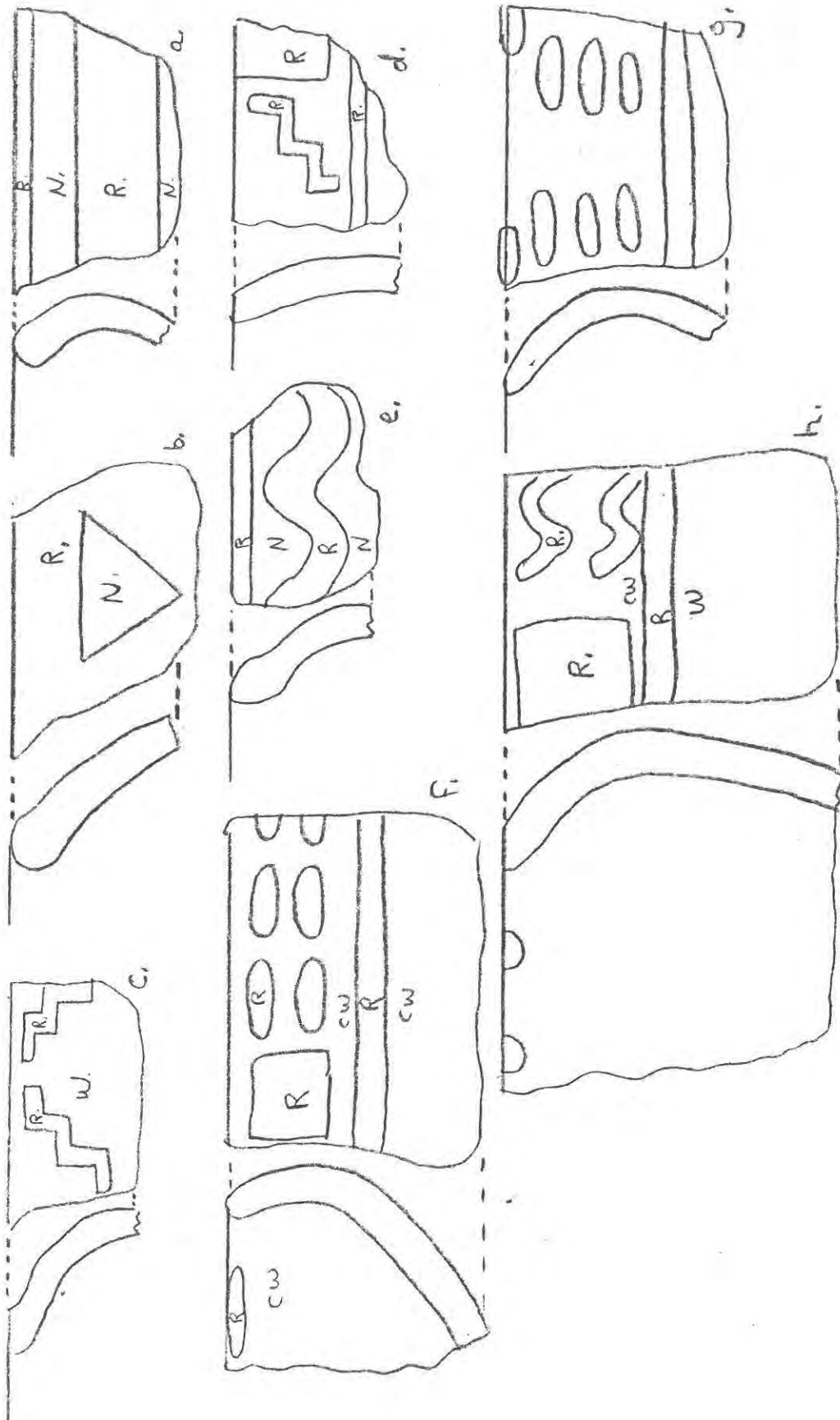

COCHACHONGOS AB

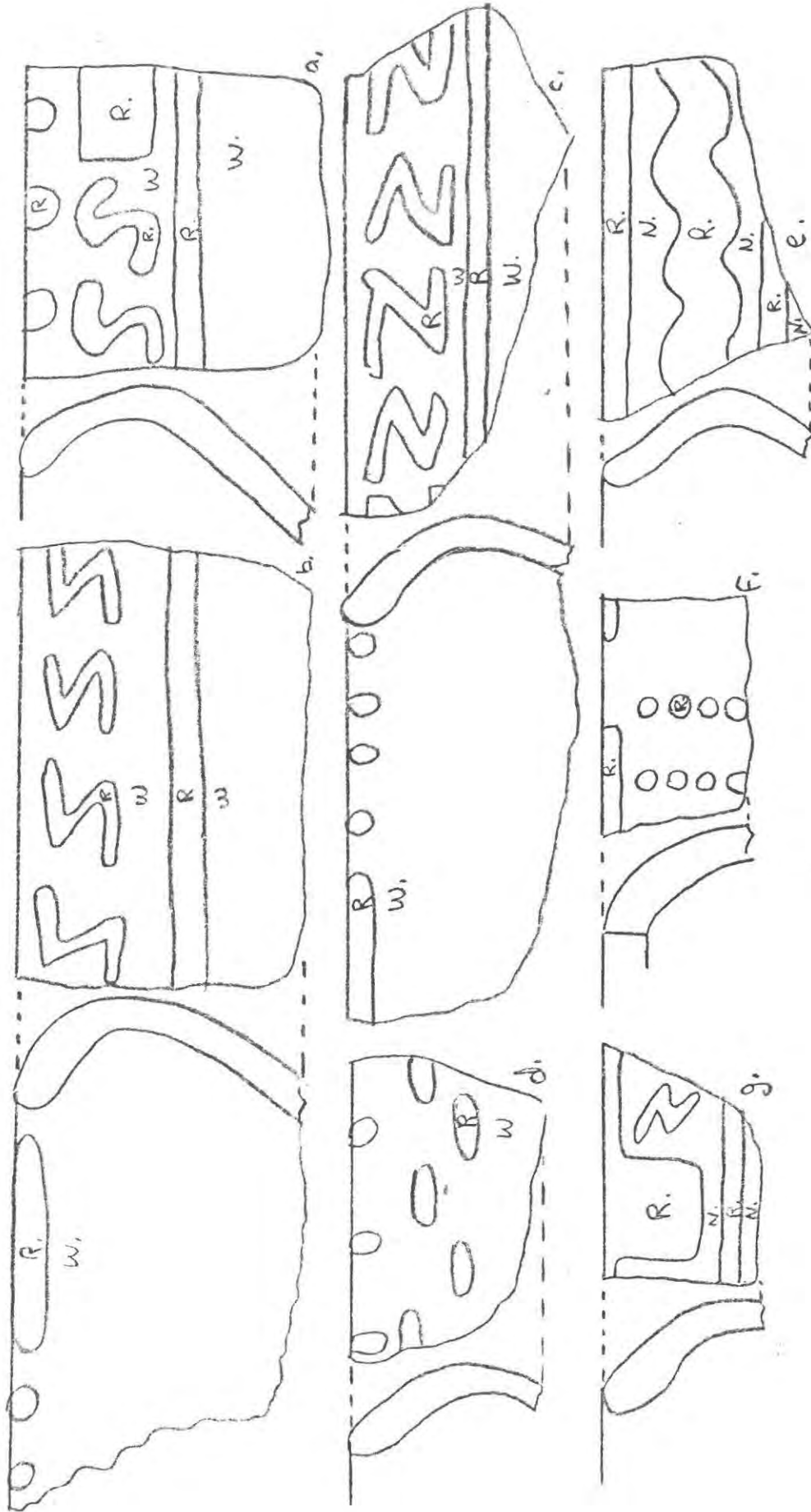

COCHACHONGOS AB

Fig. 53

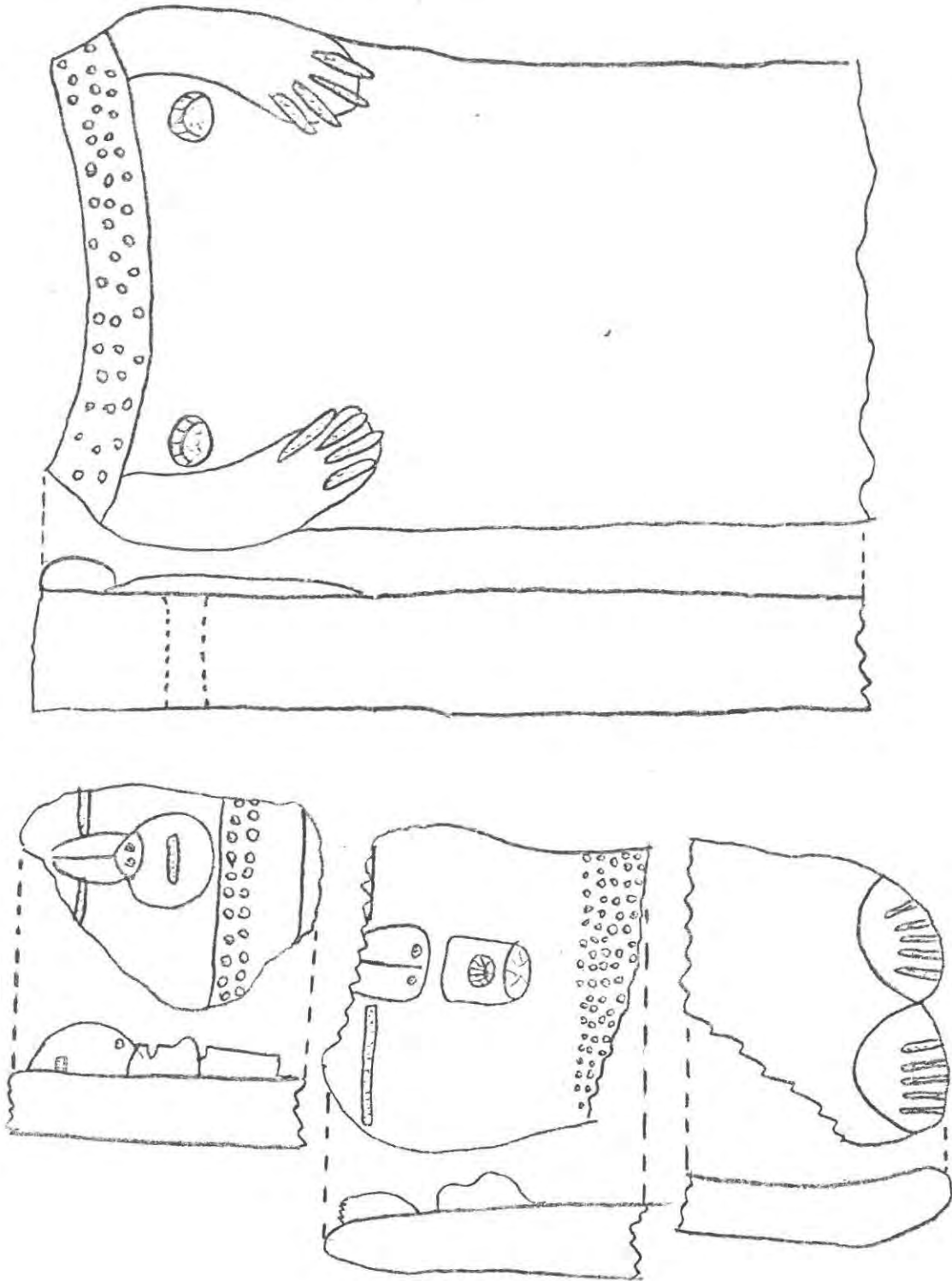

COCHACHONGOS ABÉC

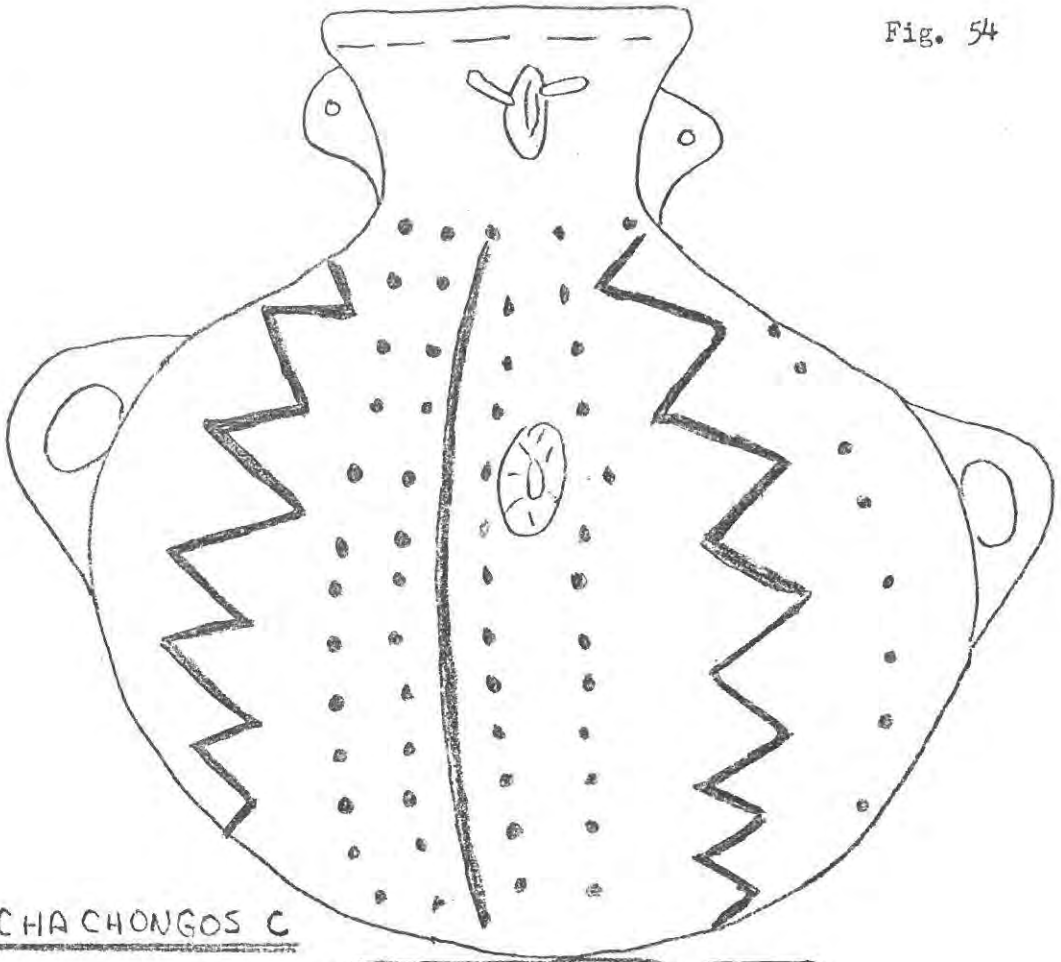

COCHACHONGOS C

PJUM 613

OFFERING DEPOSIT

(RED ON CREAM)

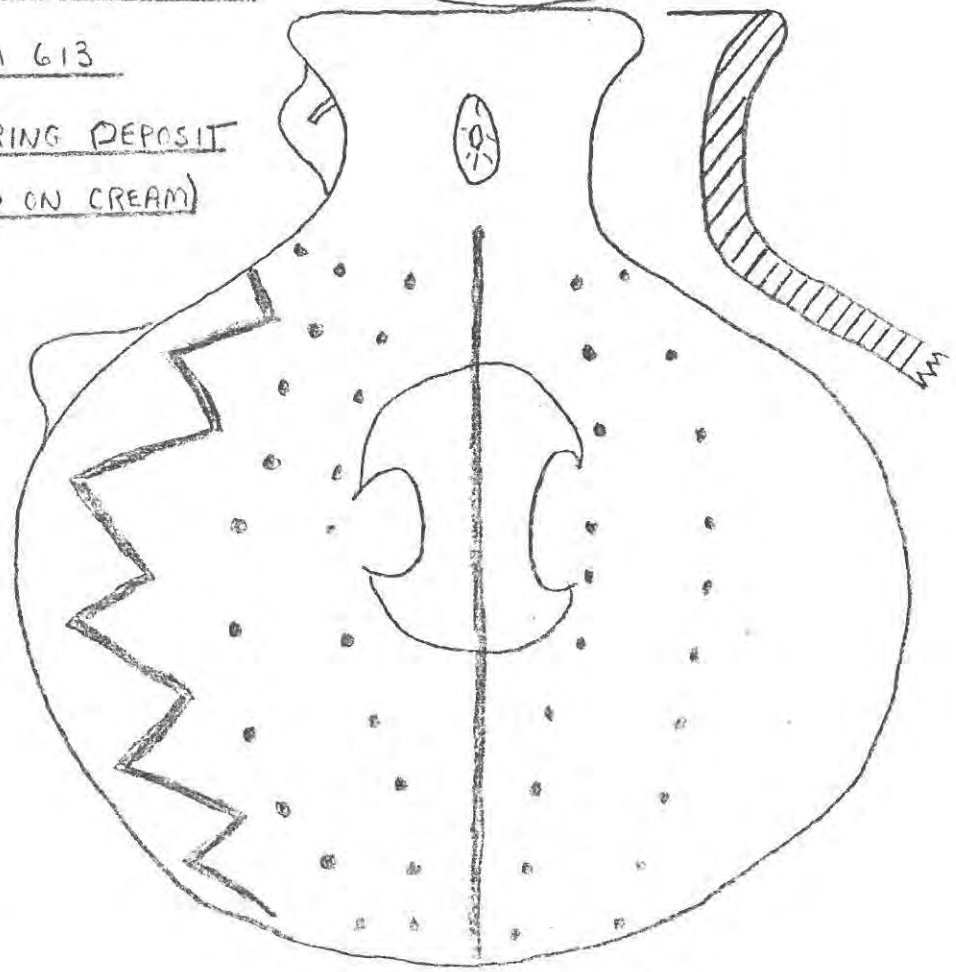

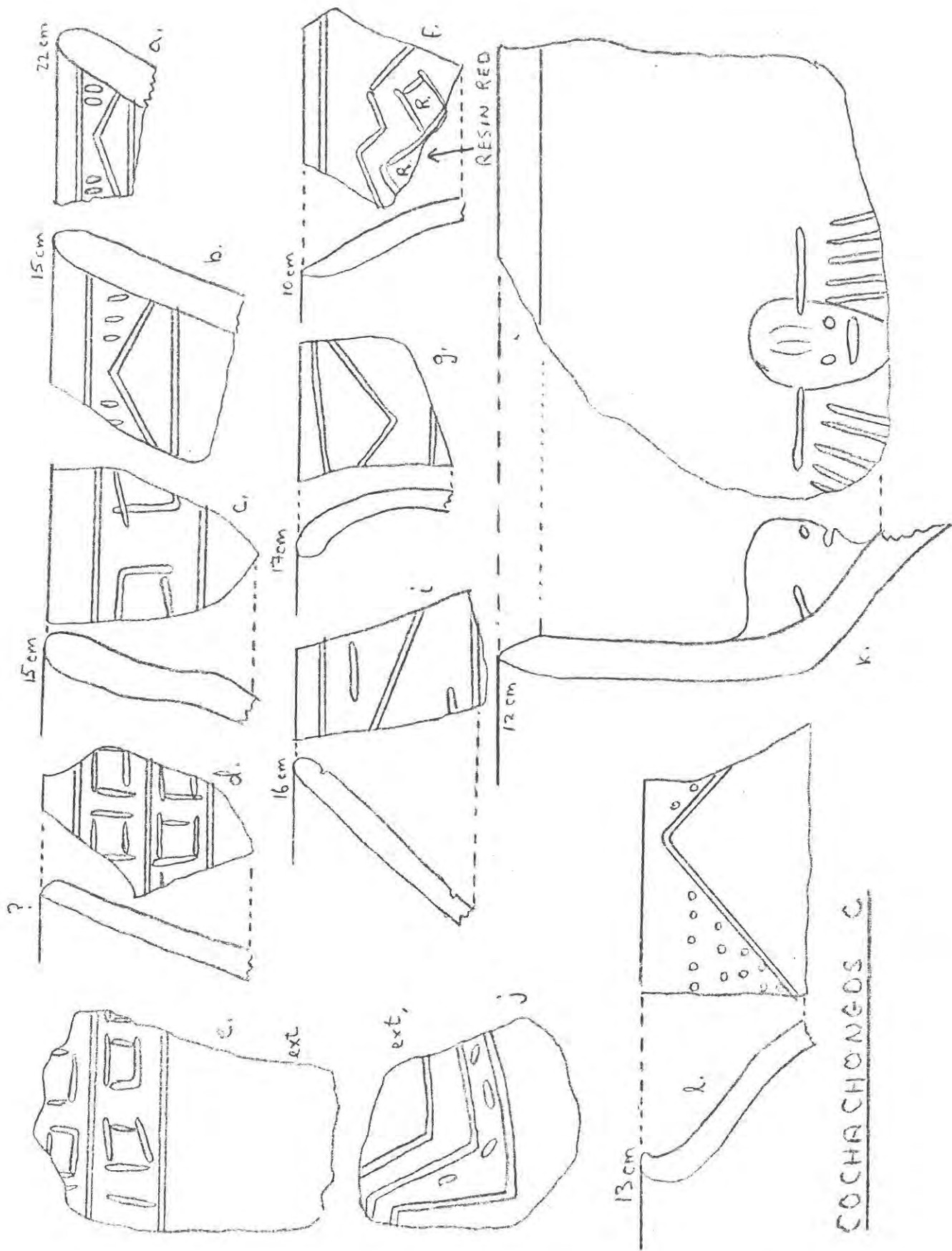
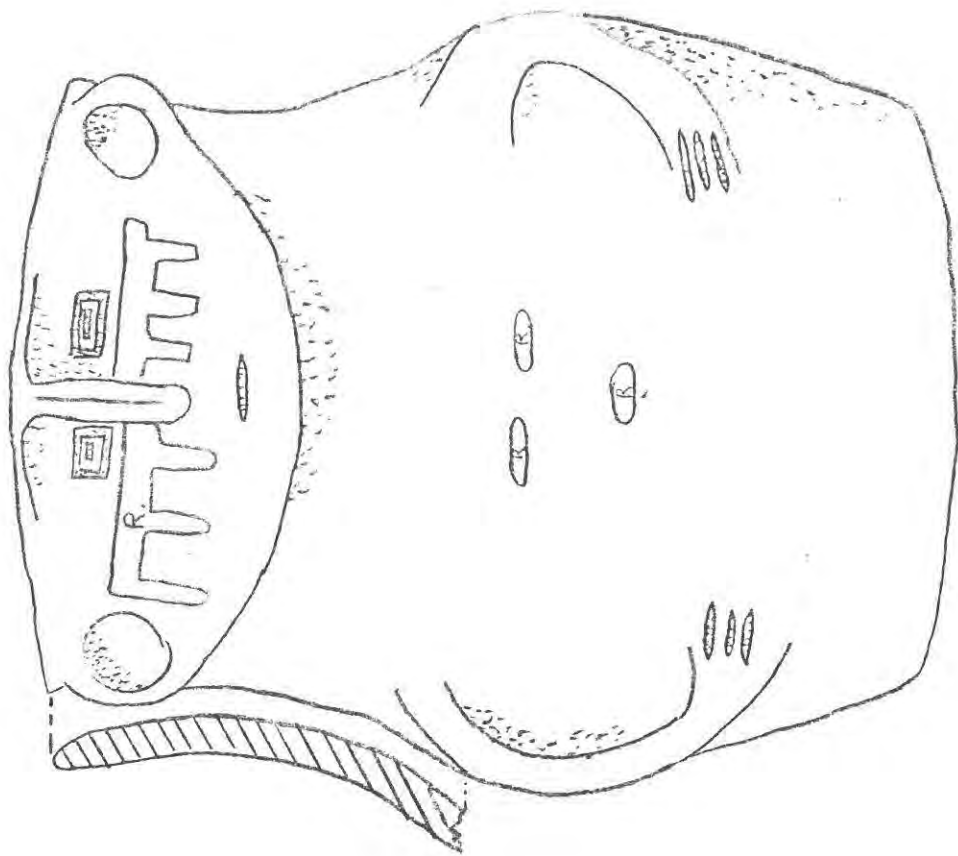
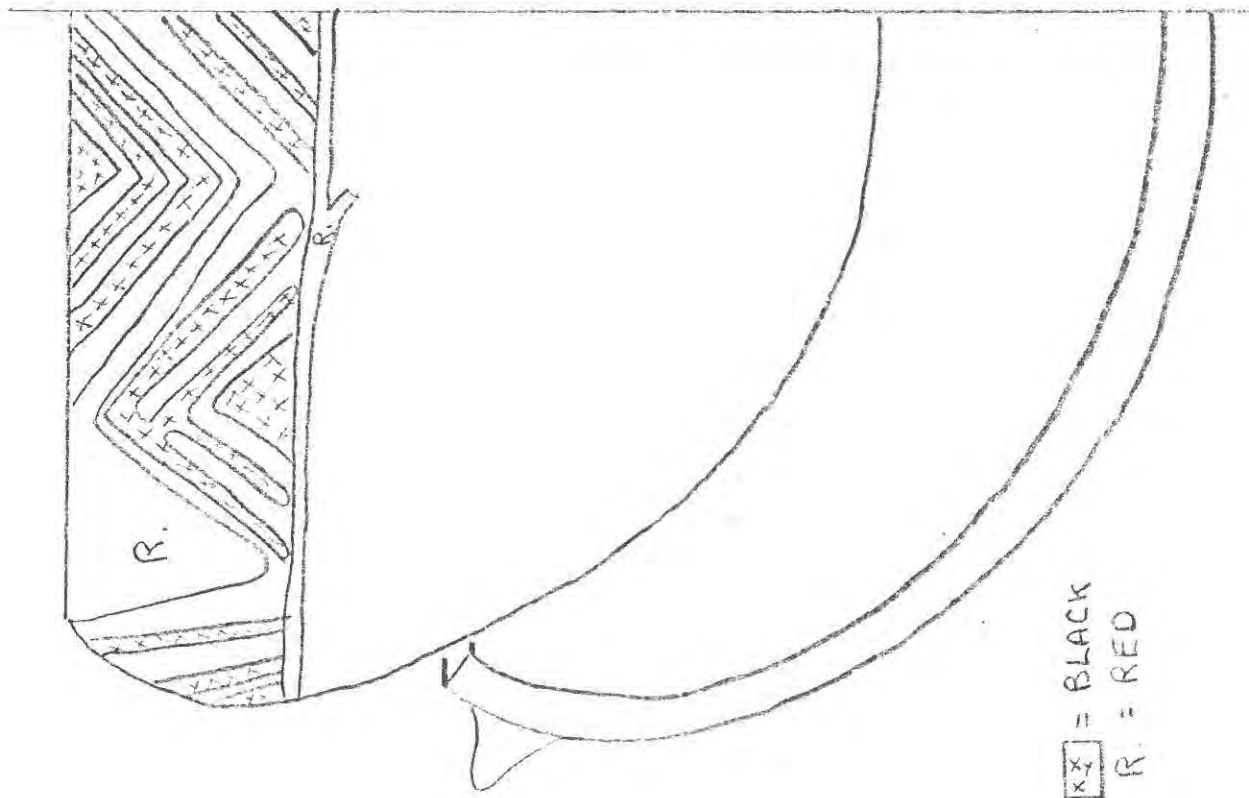

Fig. 56



COCHACHONGOS C



$\square \times \times$ = BLACK
R. = RED

Fig. 57

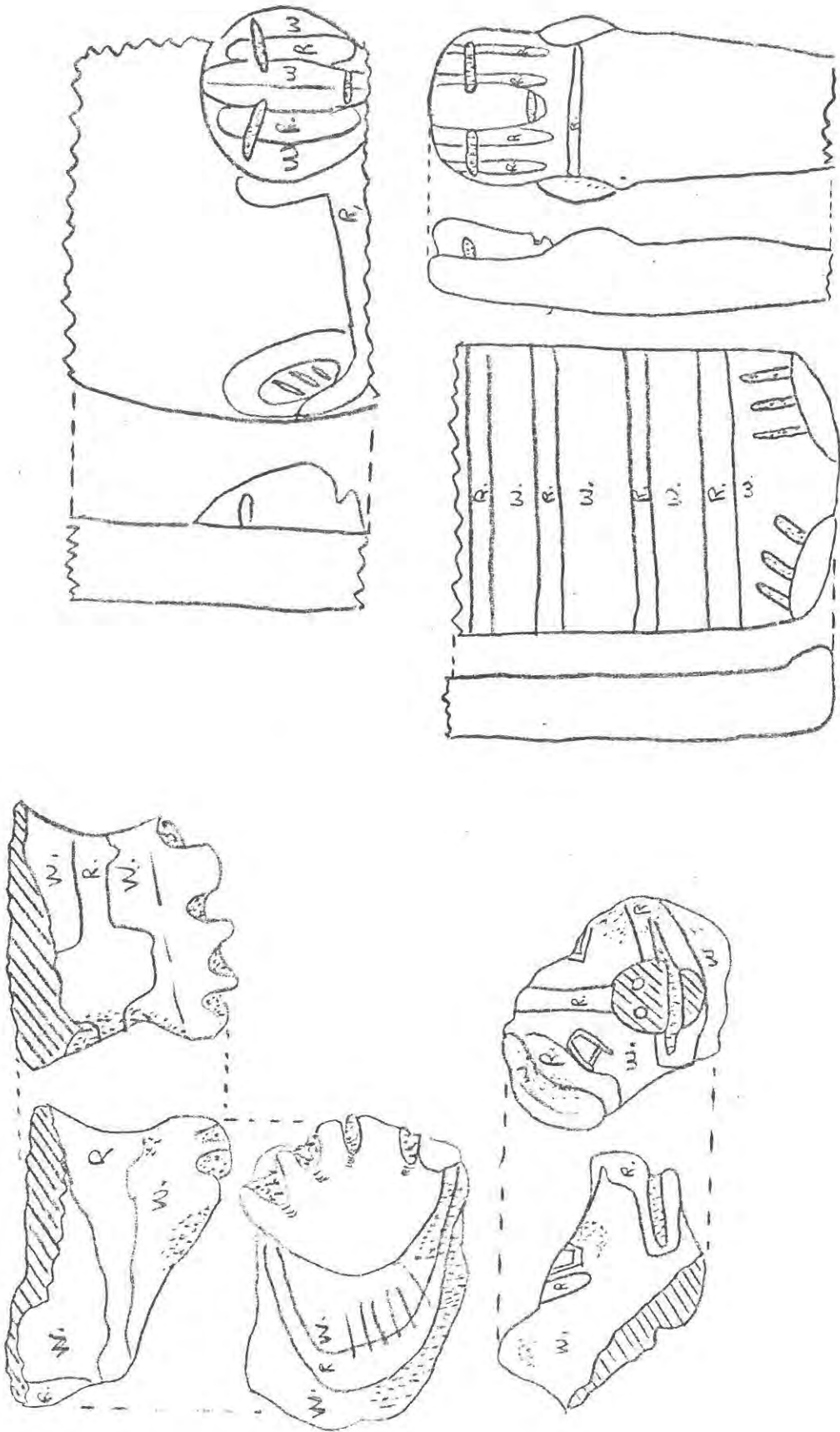

COCHACHONGOS C

Fig. 58

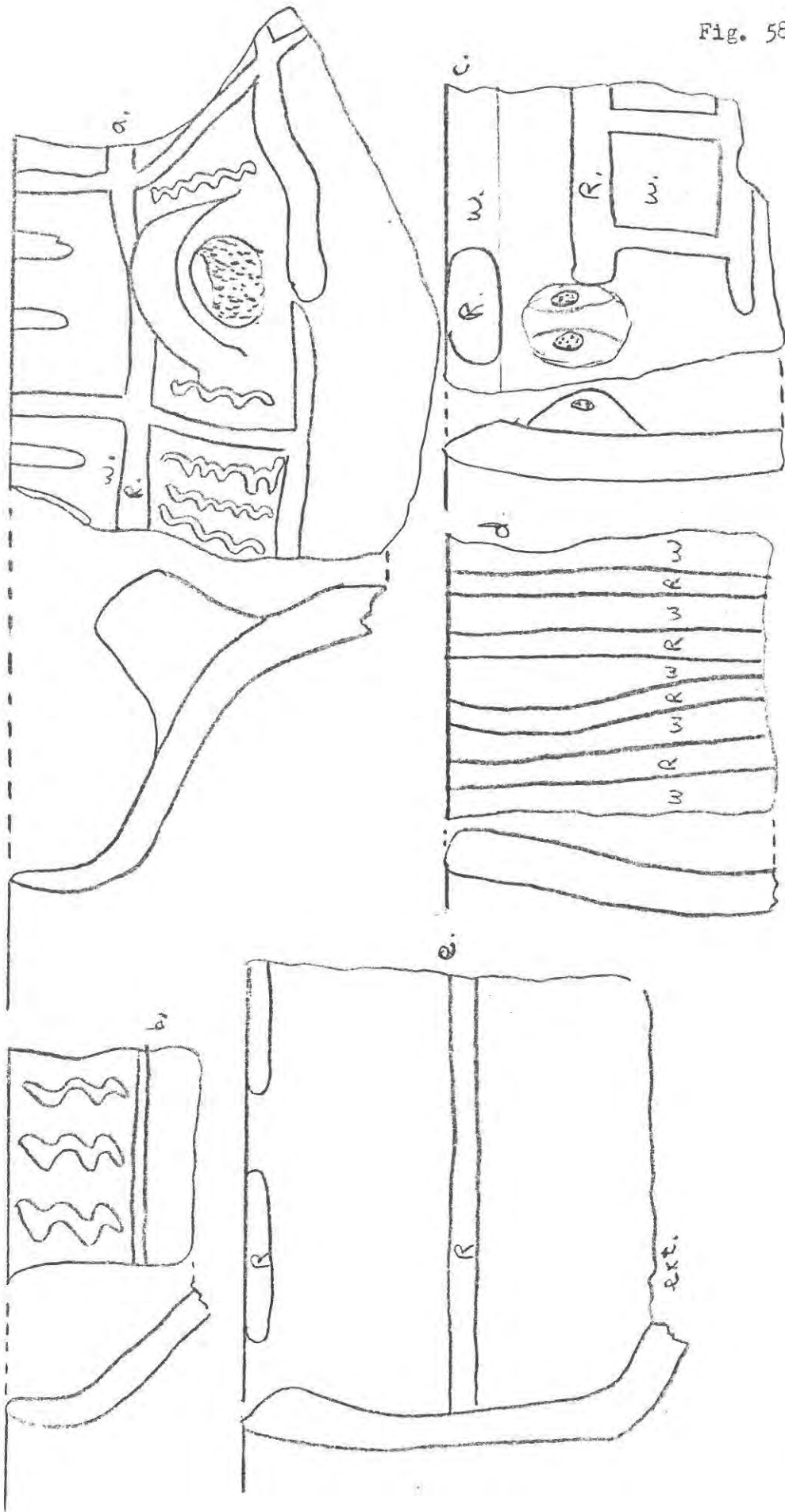

COCHACHONGOS C

Fig. 59

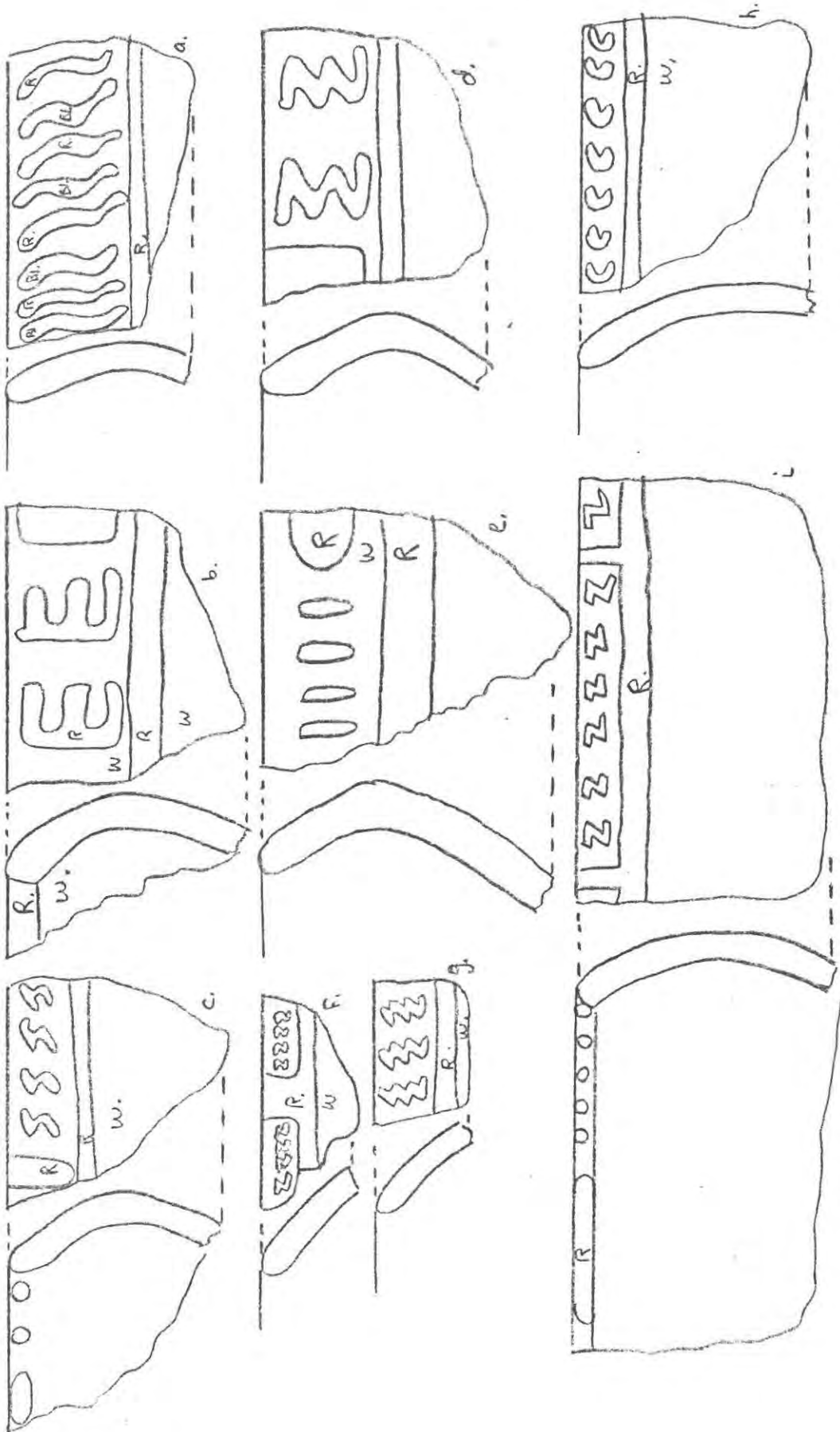

COCHACHONGOS C

Fig. 60

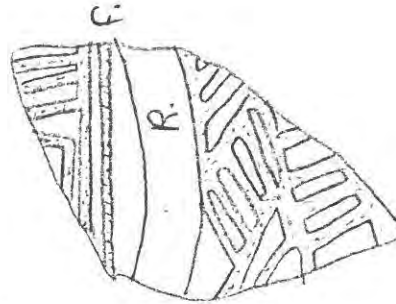
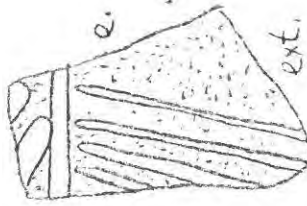
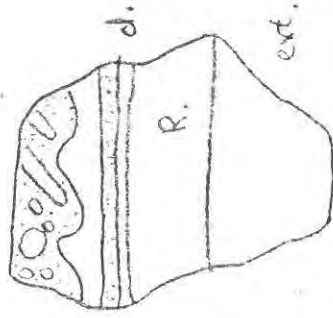
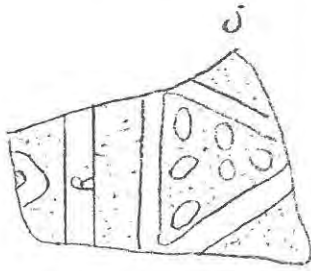
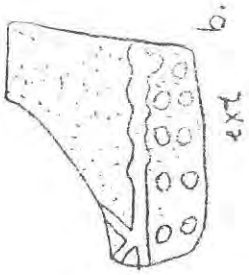
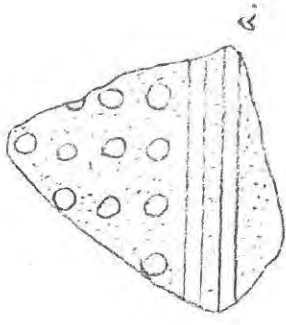

COCHACHONGOS C NEGATIVE

COCHACHONGOS D NEGATIVE

Fig. 61

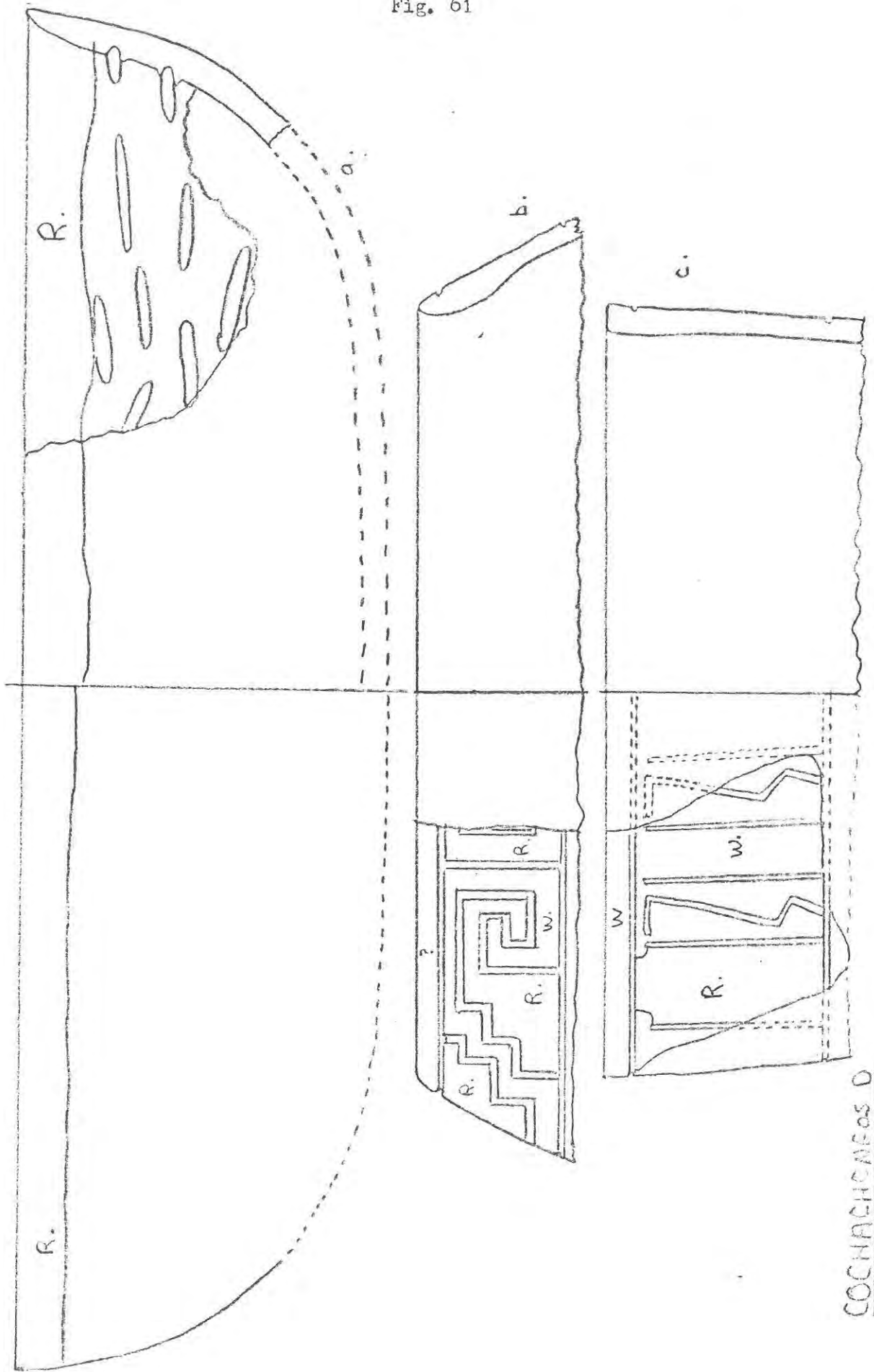

COCHACHICHIMPOS D

Fig. 62

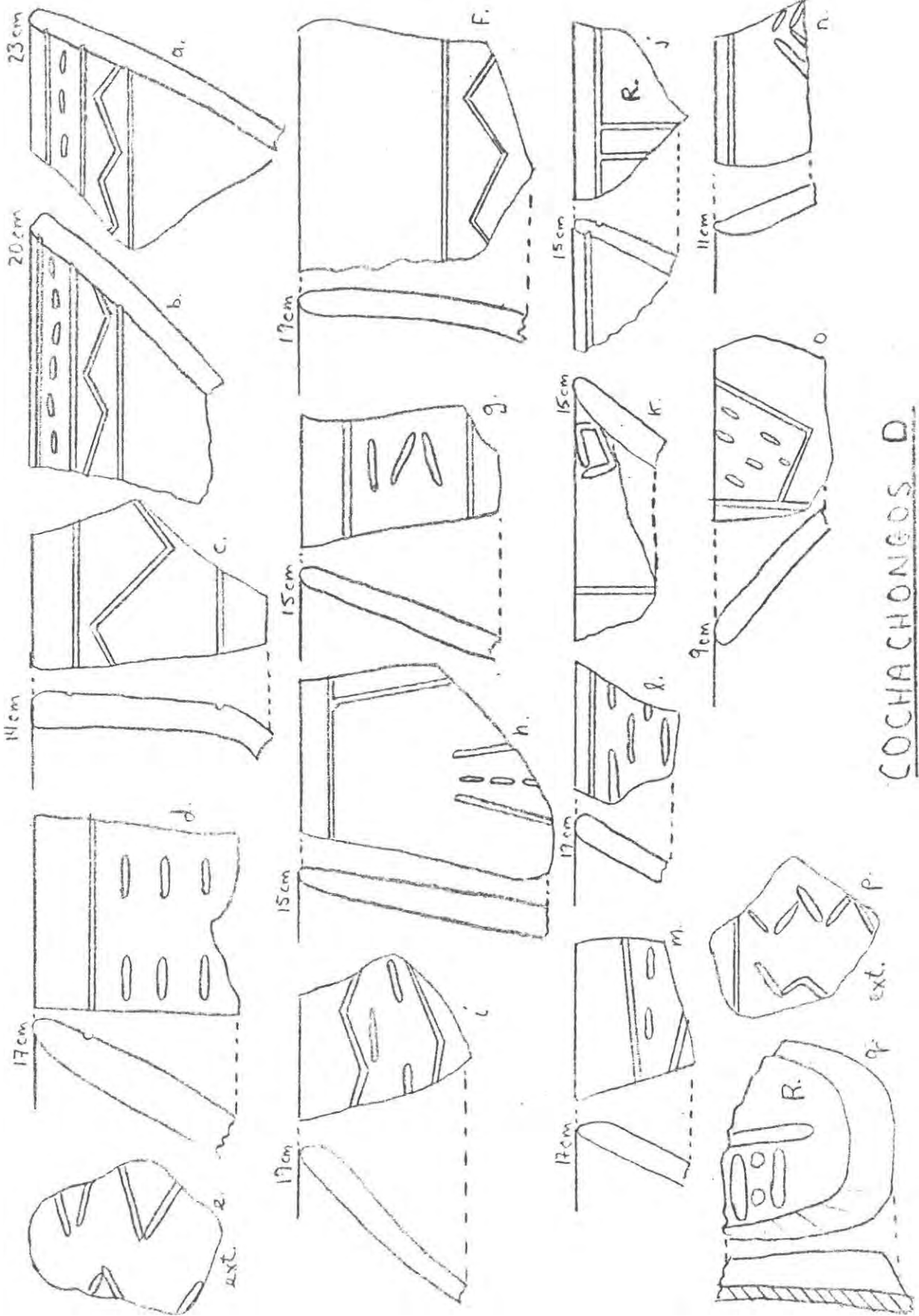

COCHACHONGOS D

Fig. 63

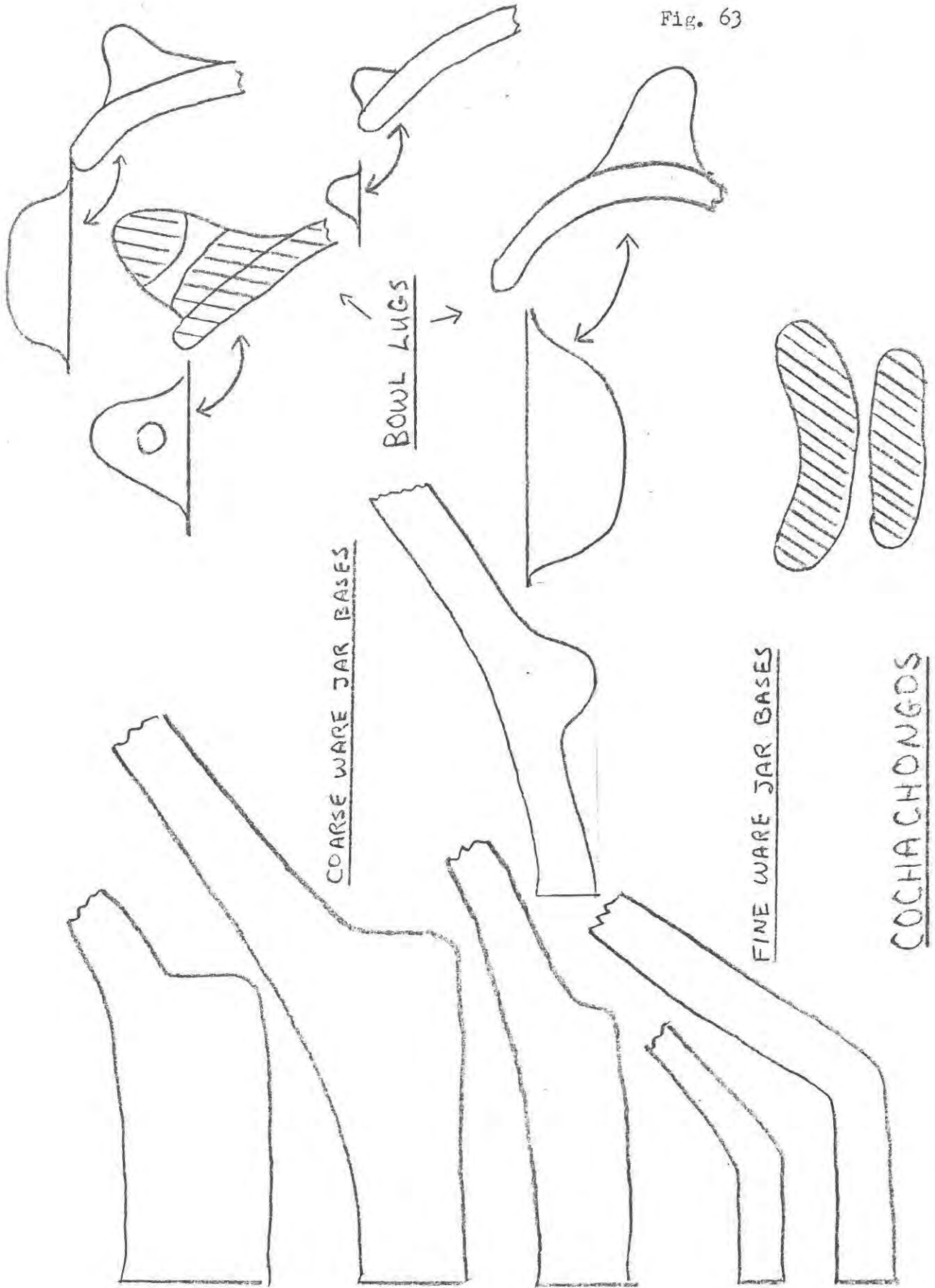

COARSE WARE JAR BASES

BOWL LUGS

FINE WARE JAR BASES

COCHACHONGOS

Fig. 64

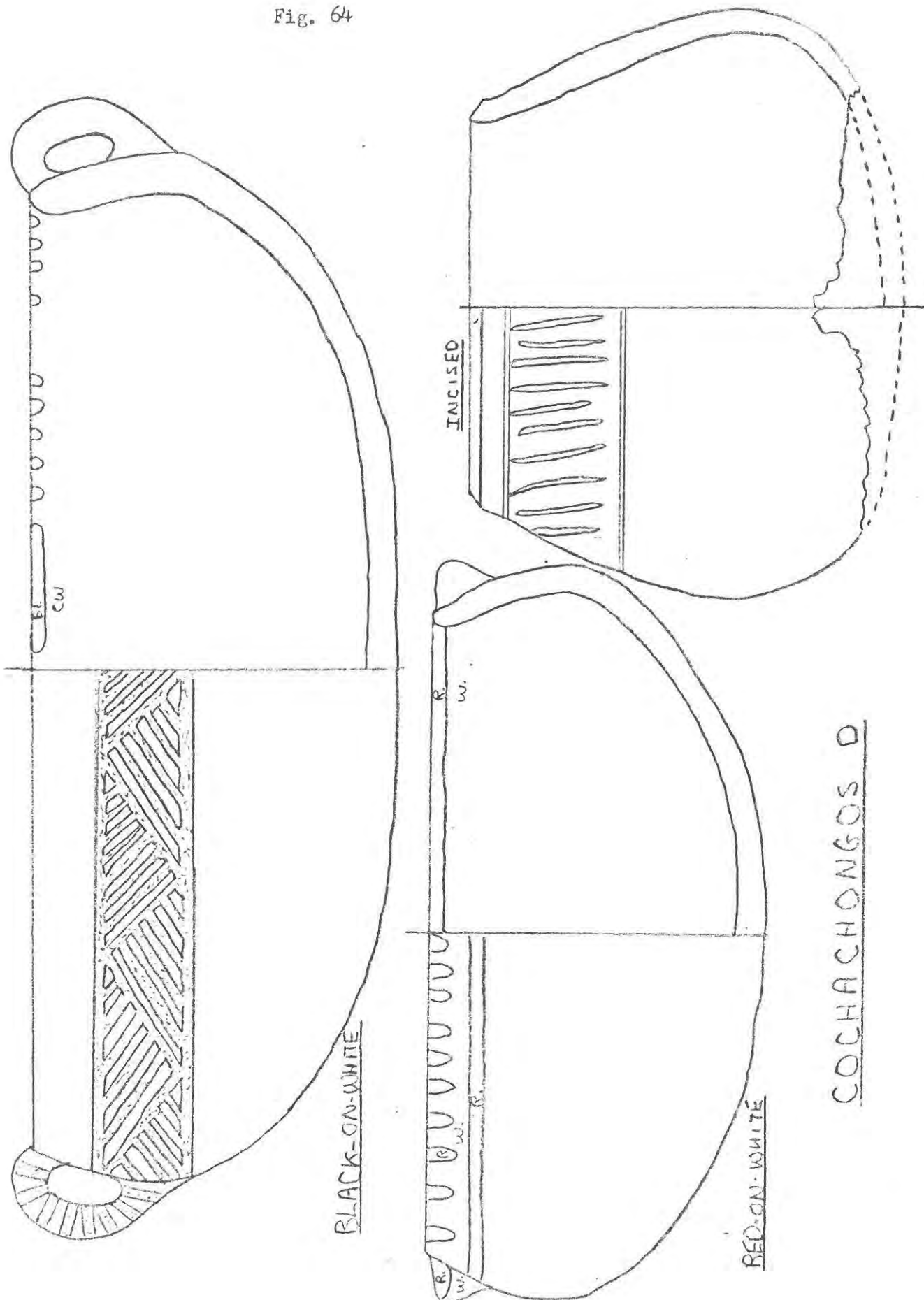
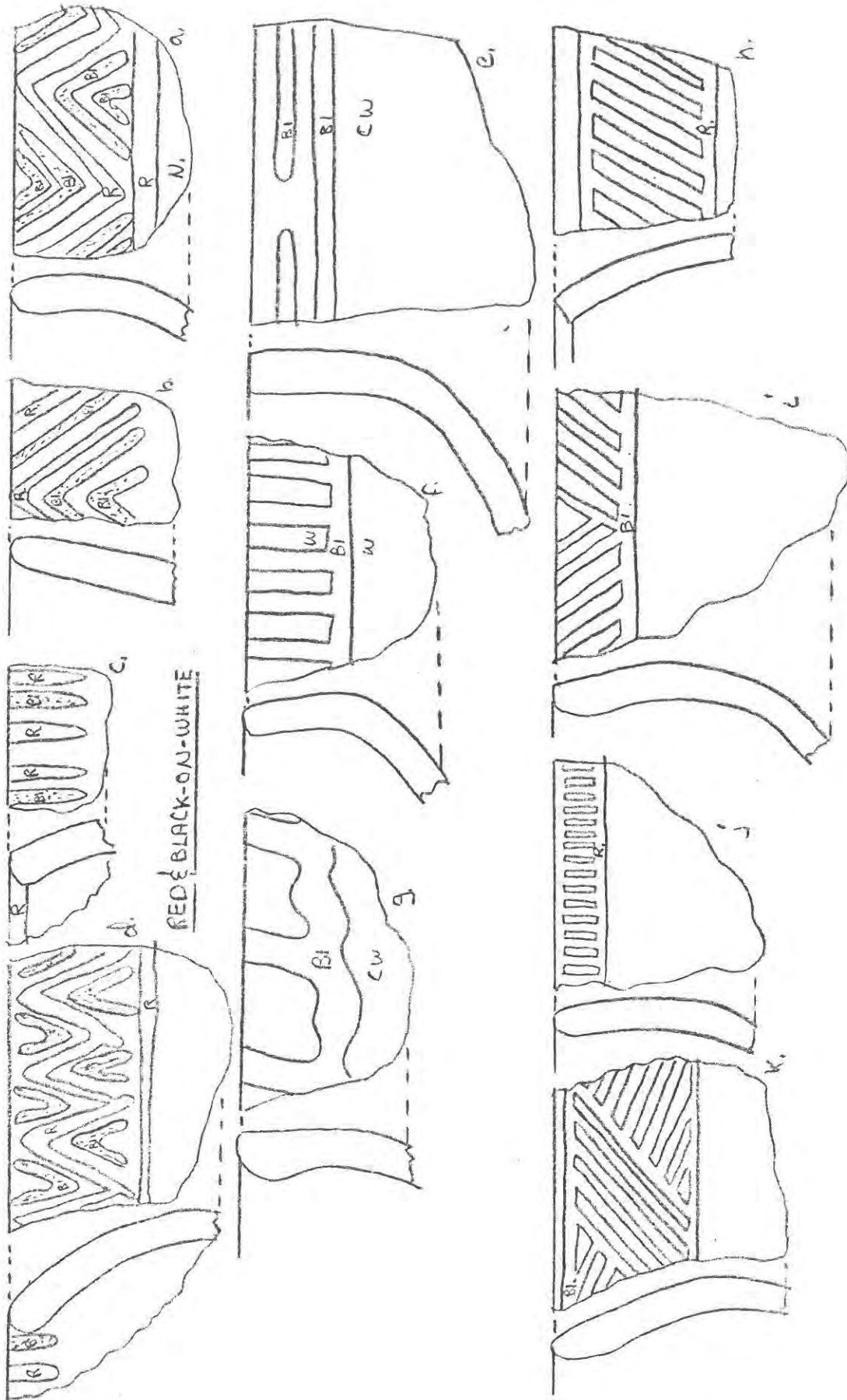
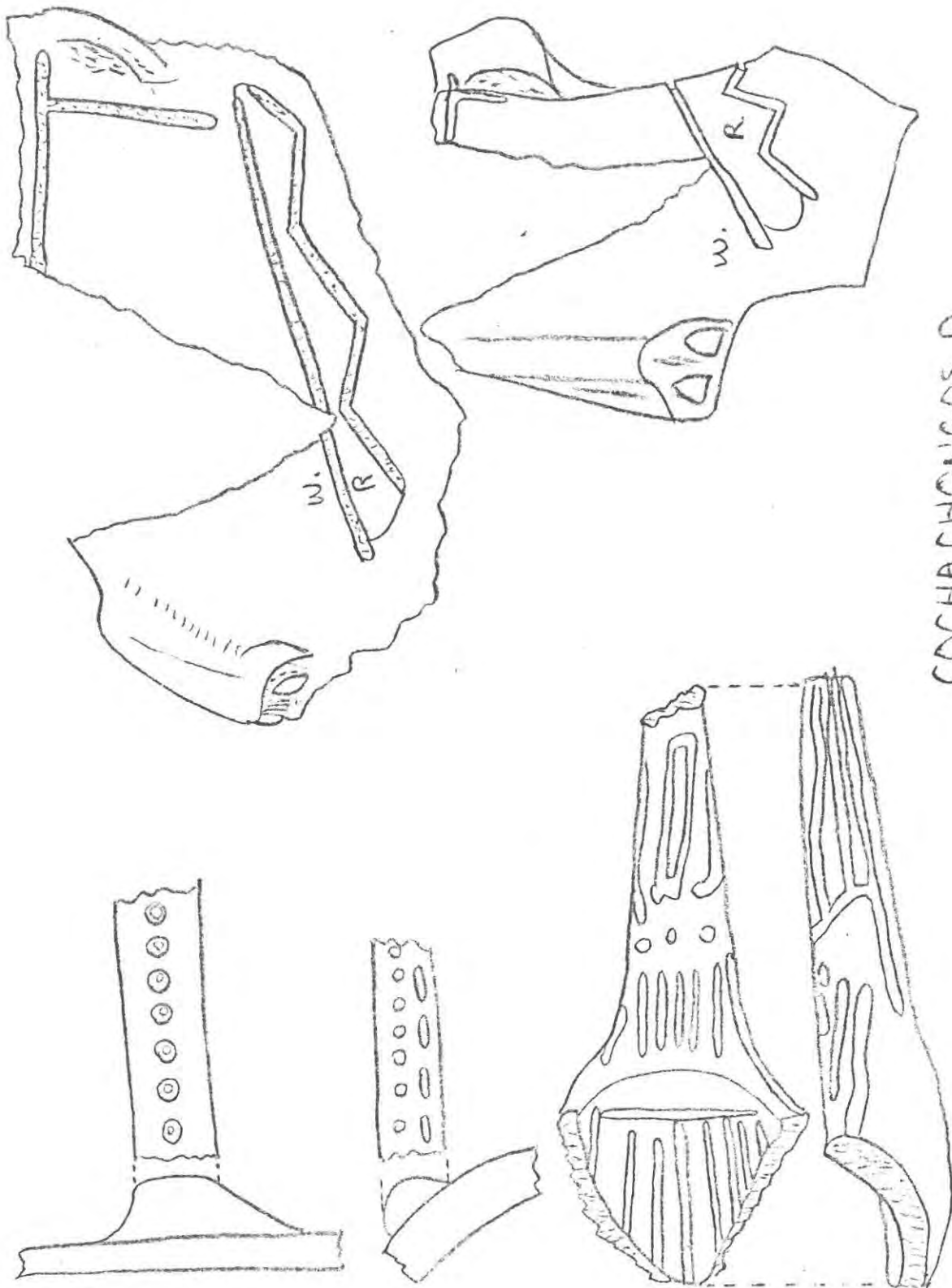

Fig. 65



COCHACHONGOS D

Fig. 66



COCHA CHONGOS D

Fig. 67

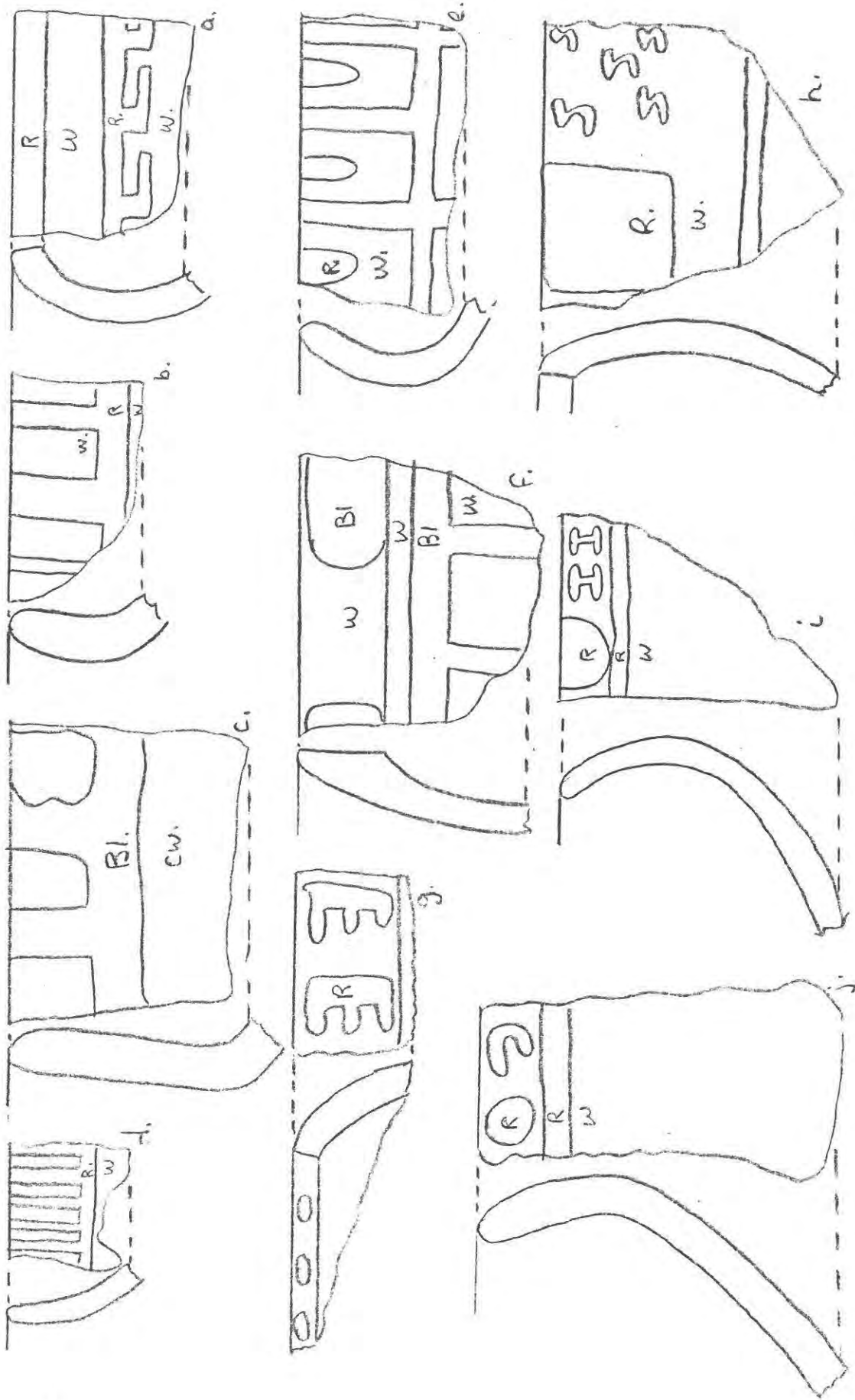

COCHACHONGOS D

Fig. 68

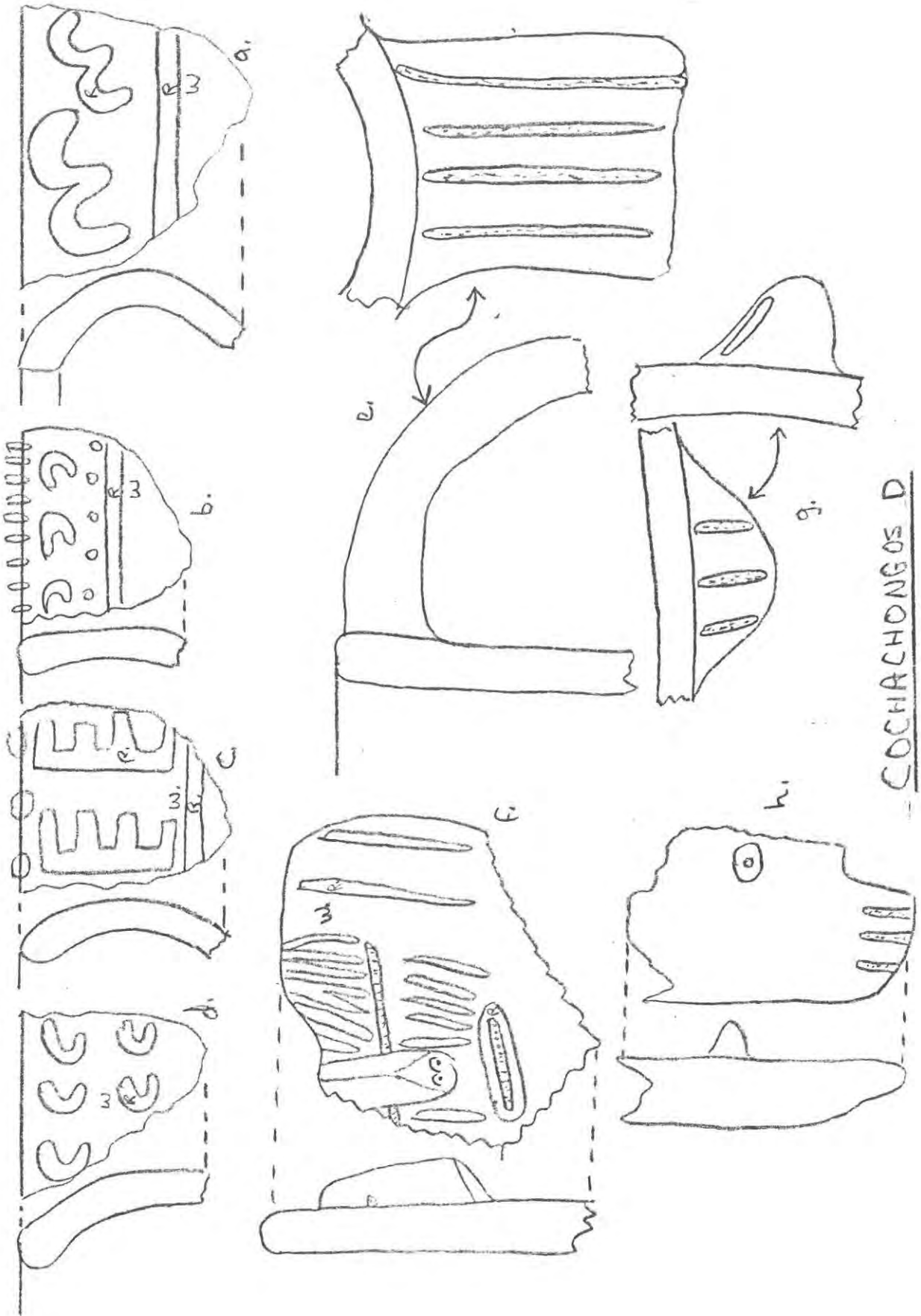

COCHACHONGOS D

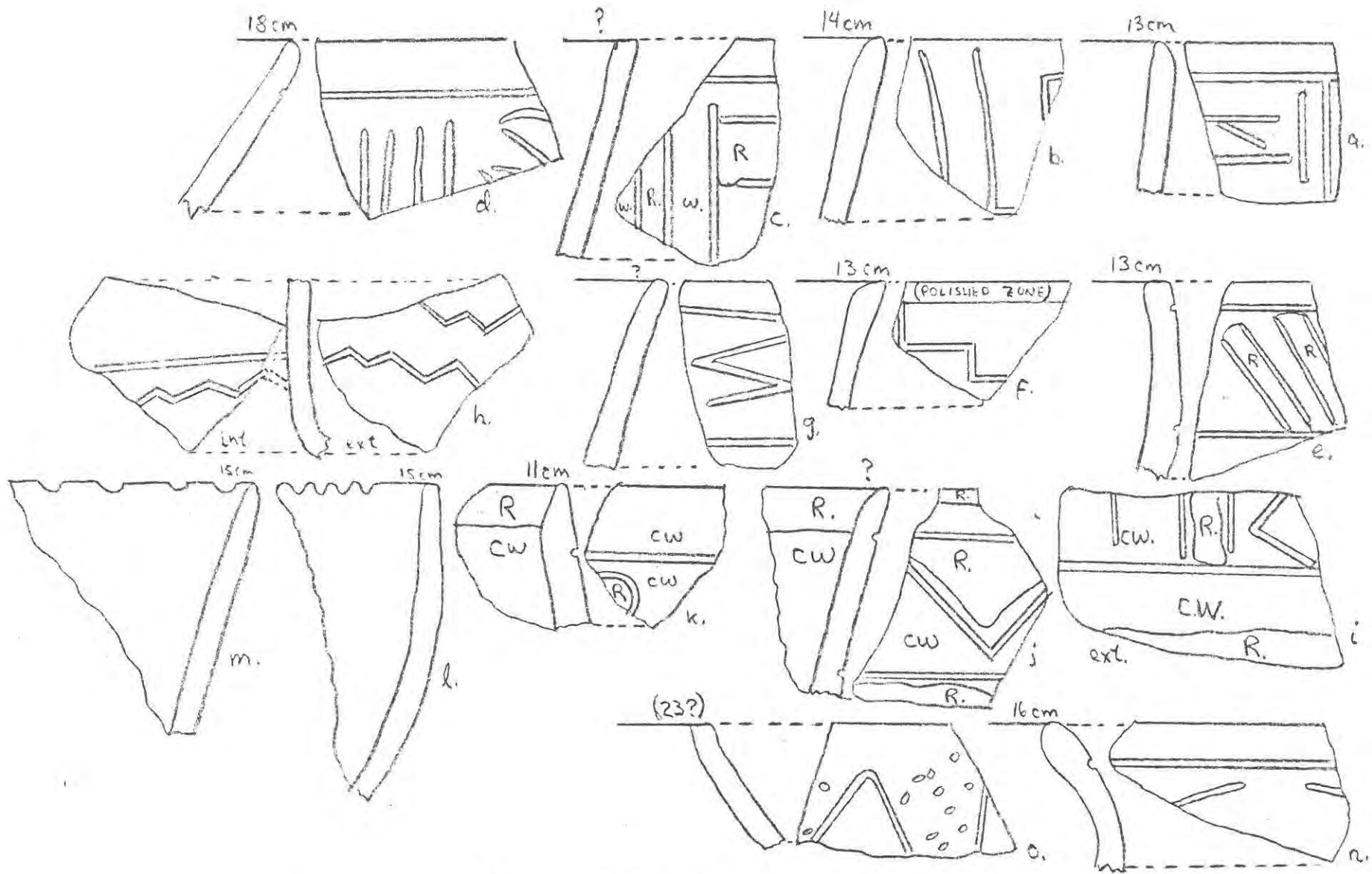
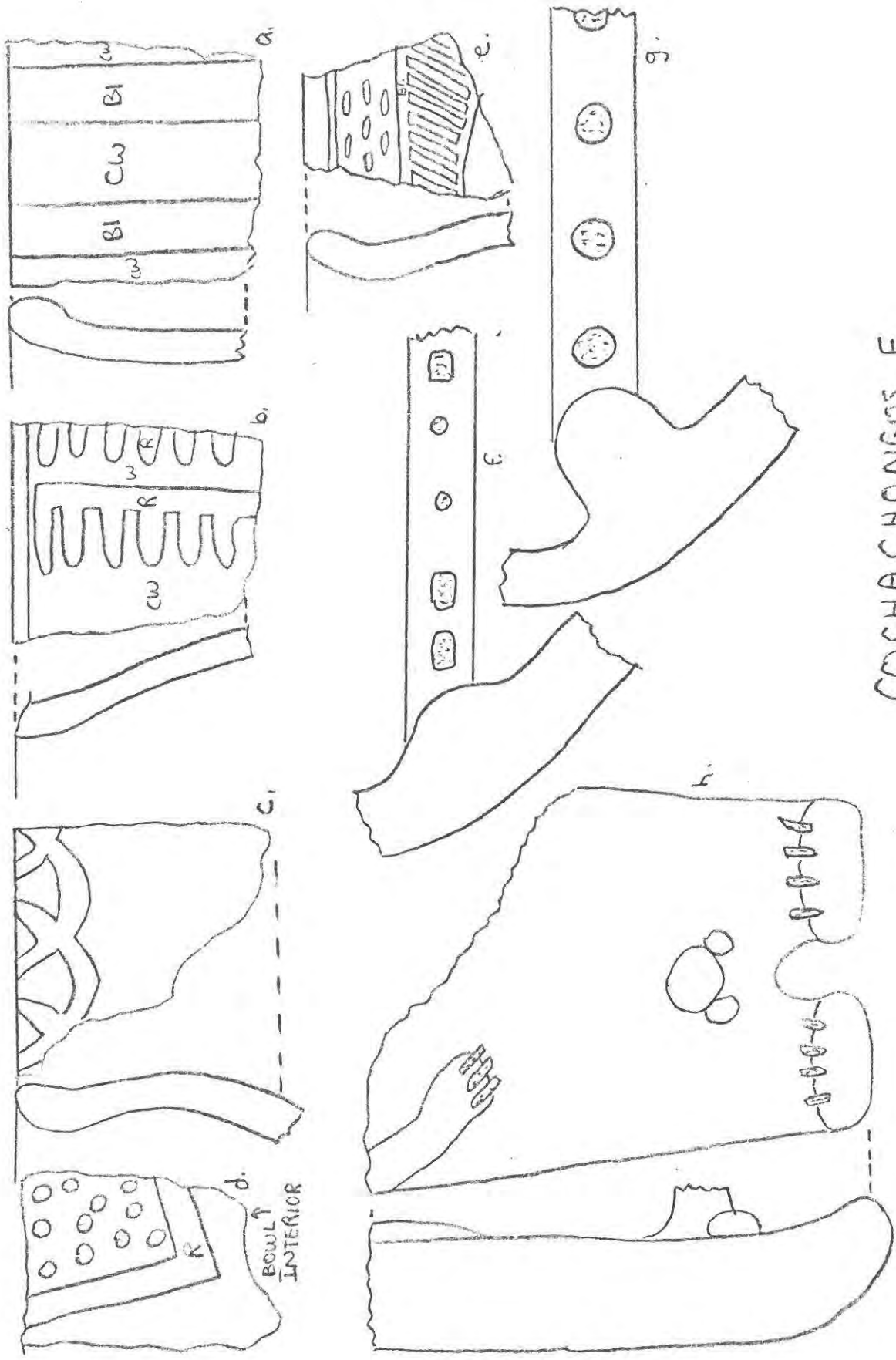

Fig. 69

COCHACHONGOS E

Fig. 70



COCHACHONGOS E

Fig. 71

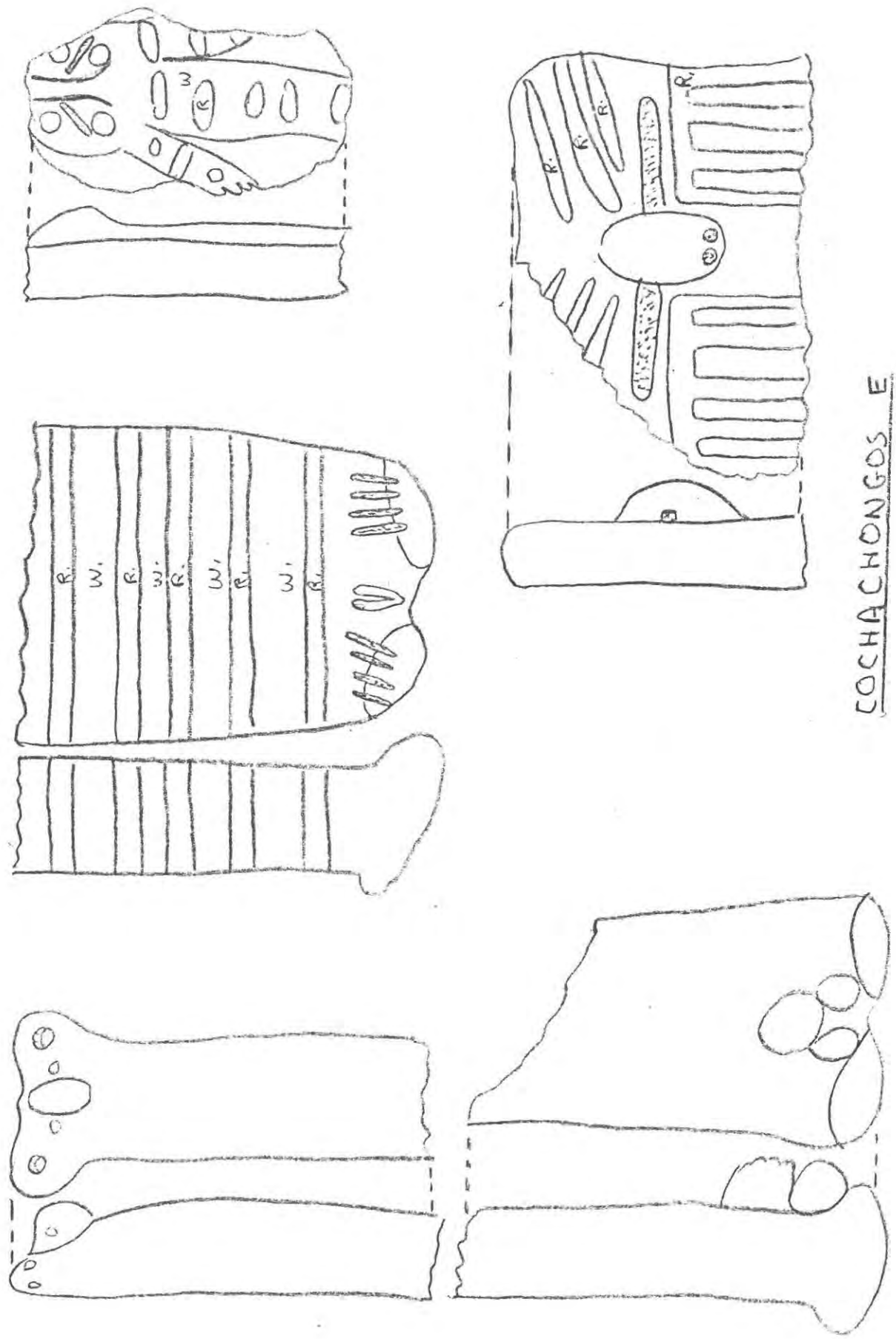

COCHACHONGOS E

Fig. 72

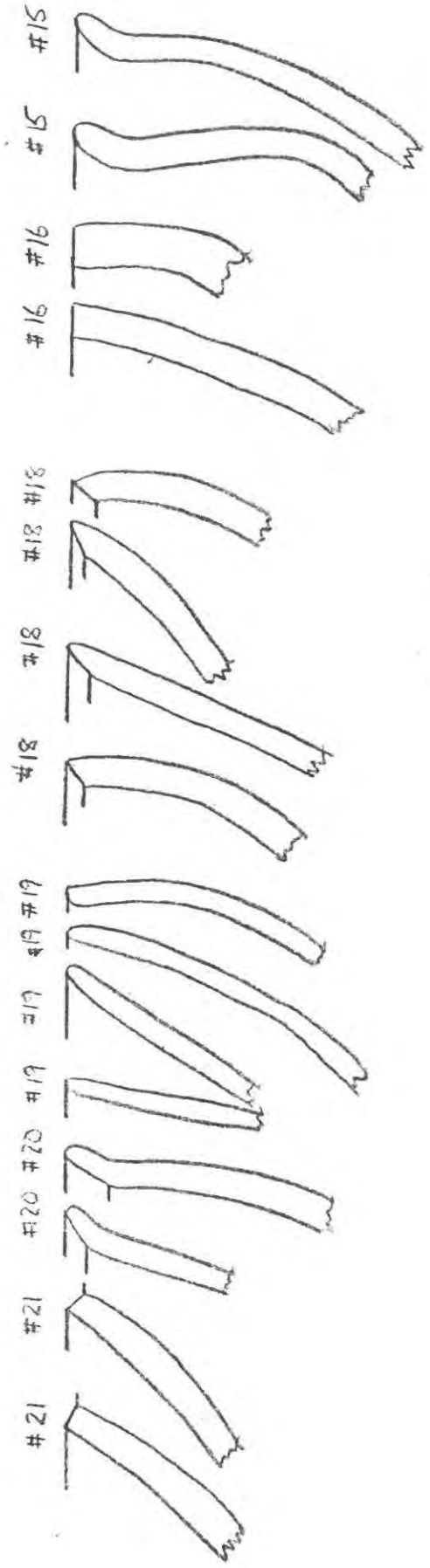
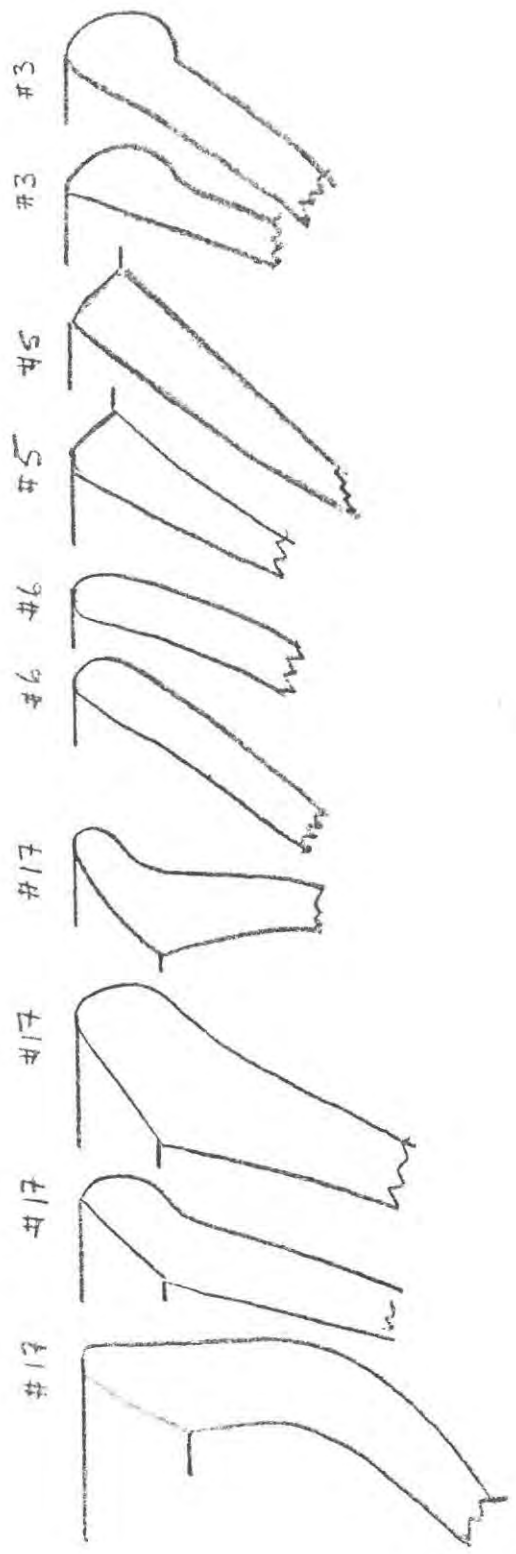

UCHUPAS OPEN BOWLS

Fig. 73

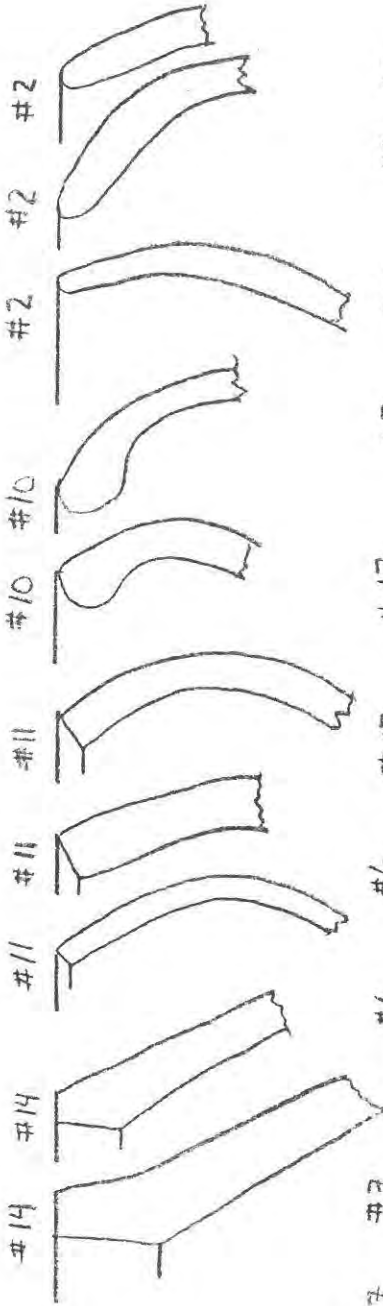

ENCLOSED BOWLS

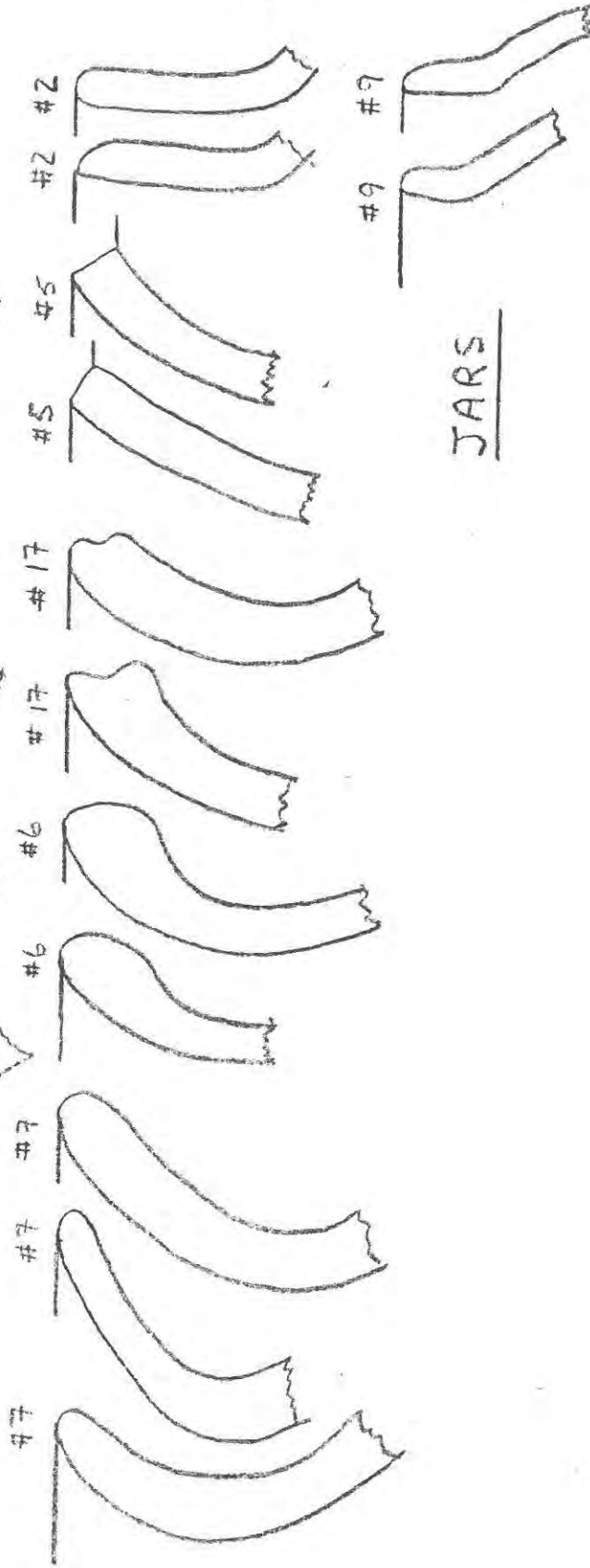

JARS

UCHUPAS JARS & ENCLOSED BOWLS

Fig. 74

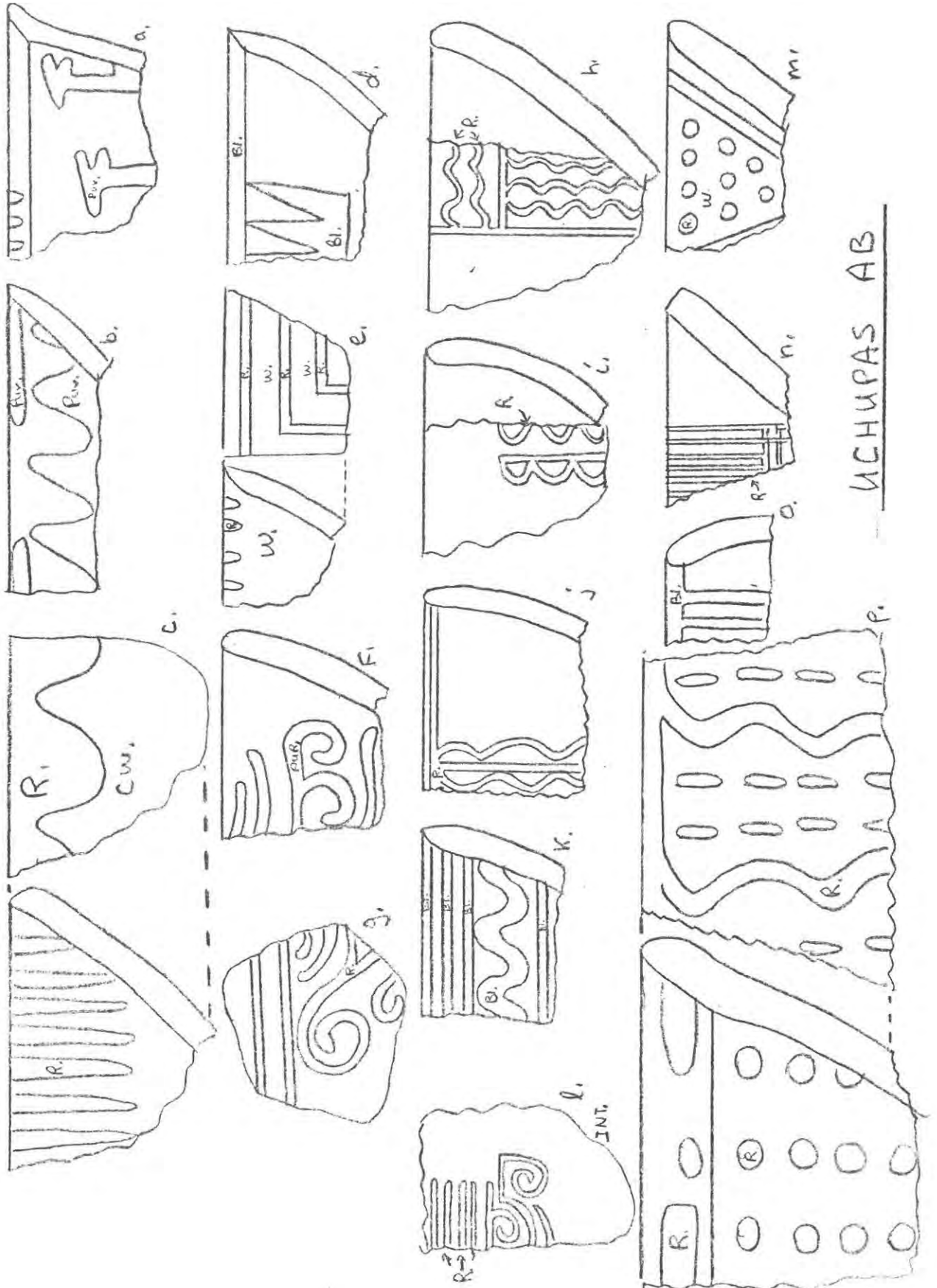
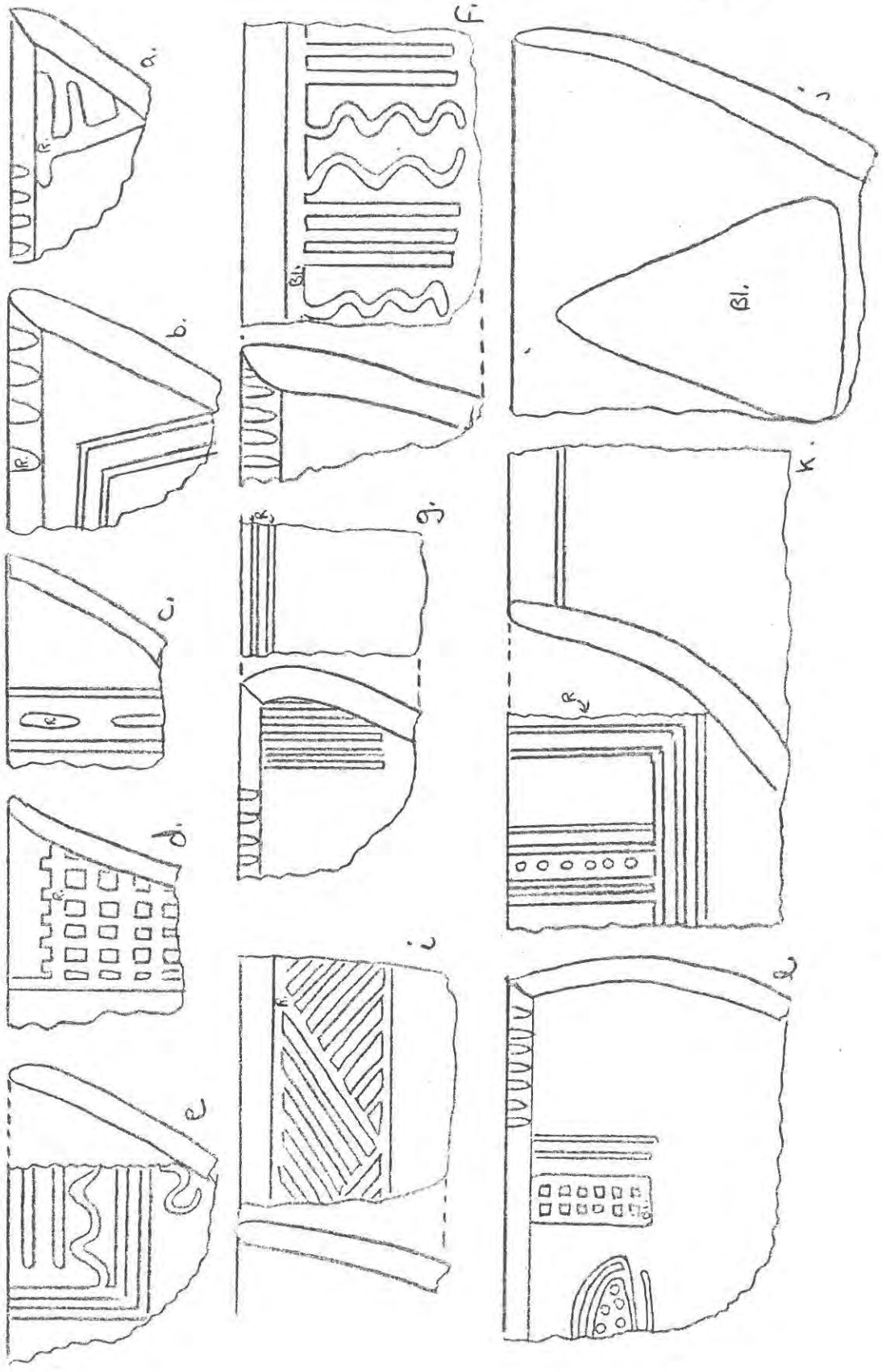
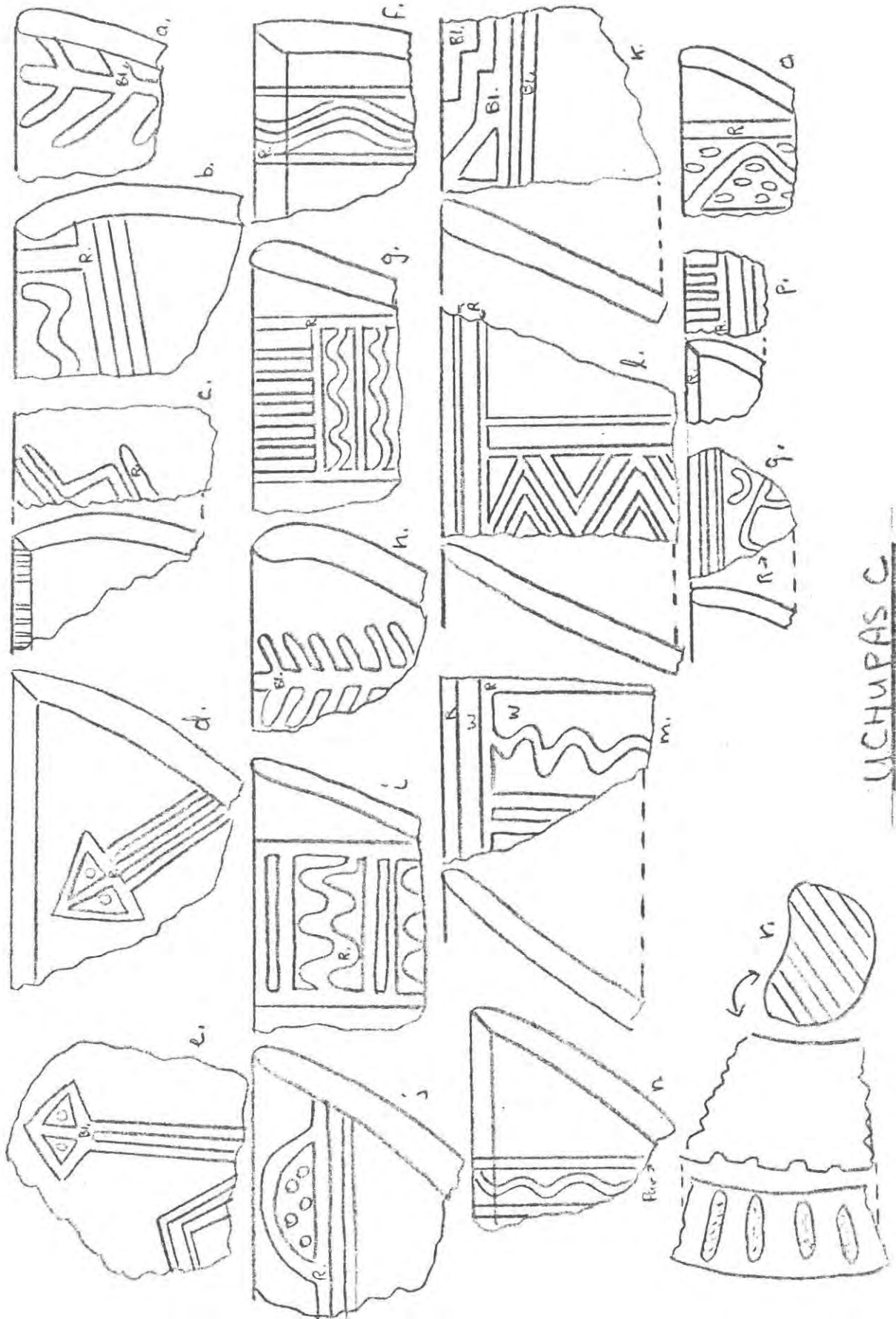

Fig. 75



UCHUPAS C

Fig. 76



UCHUPAS C

Fig. 77

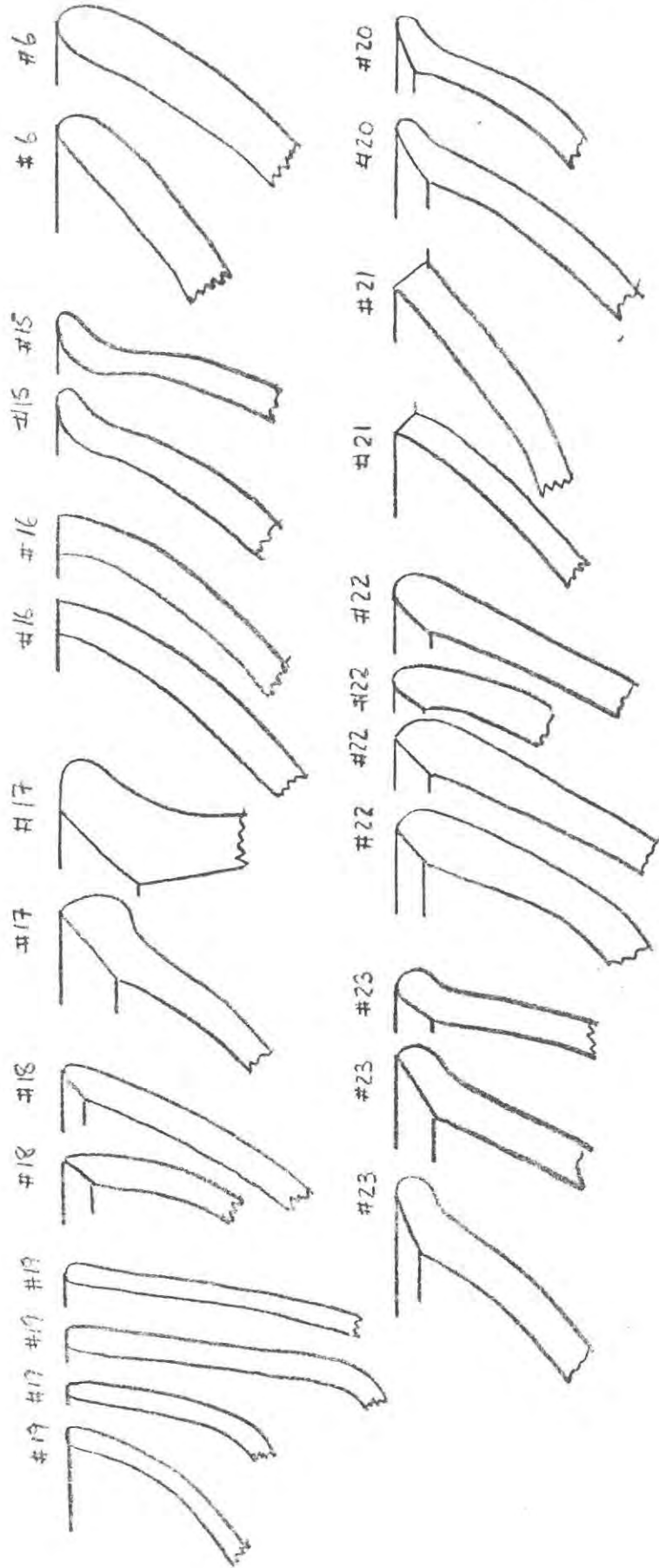

WASH PUQUILIO OPEN BOWLS

Fig. 78

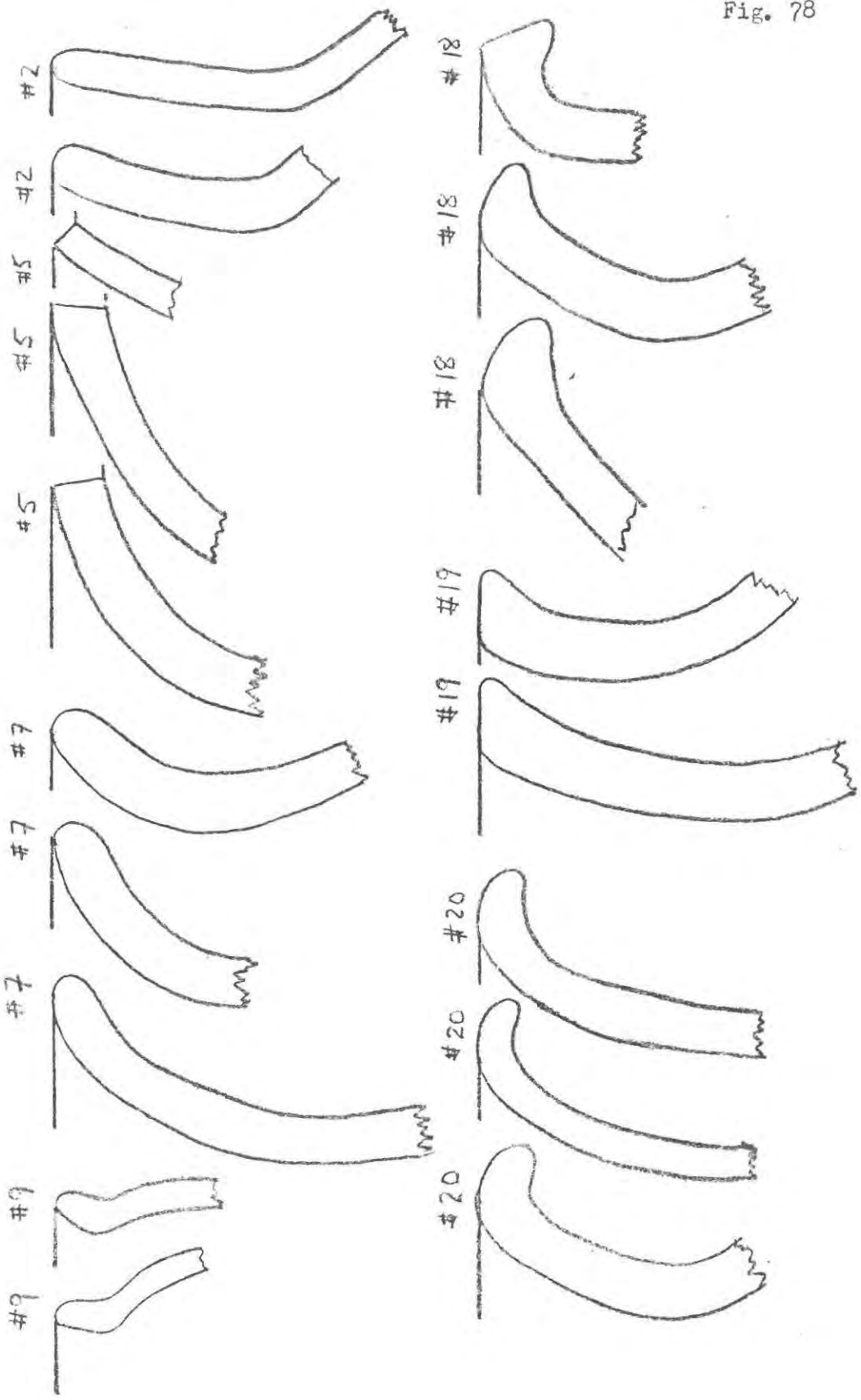

USUPUQUIO JARS

Fig. 79

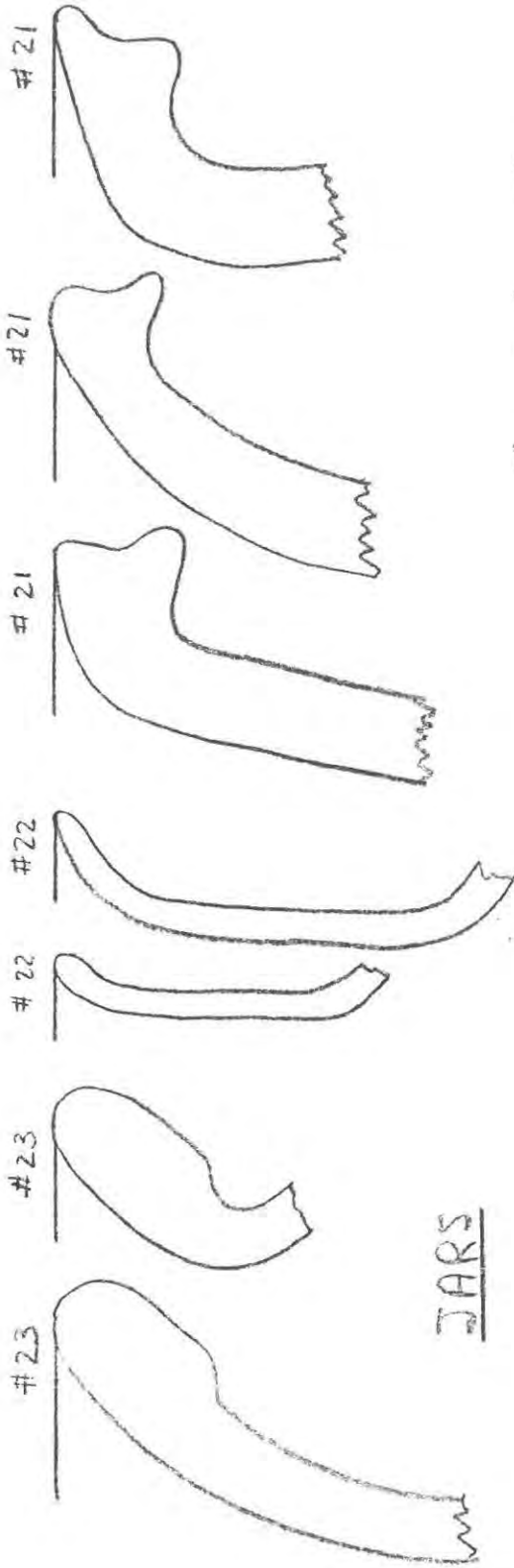

JARS

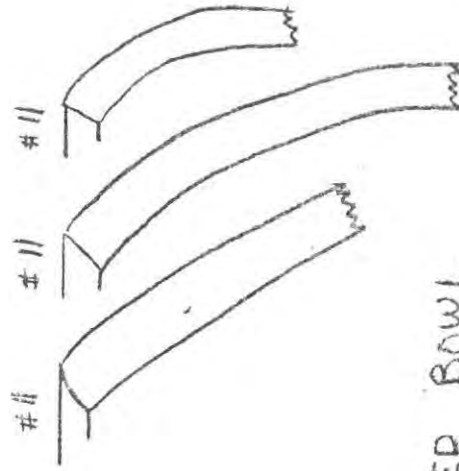

LID

ENCLOSED BOWL

USUPUQUIO - VARIOUS

Fig. 80

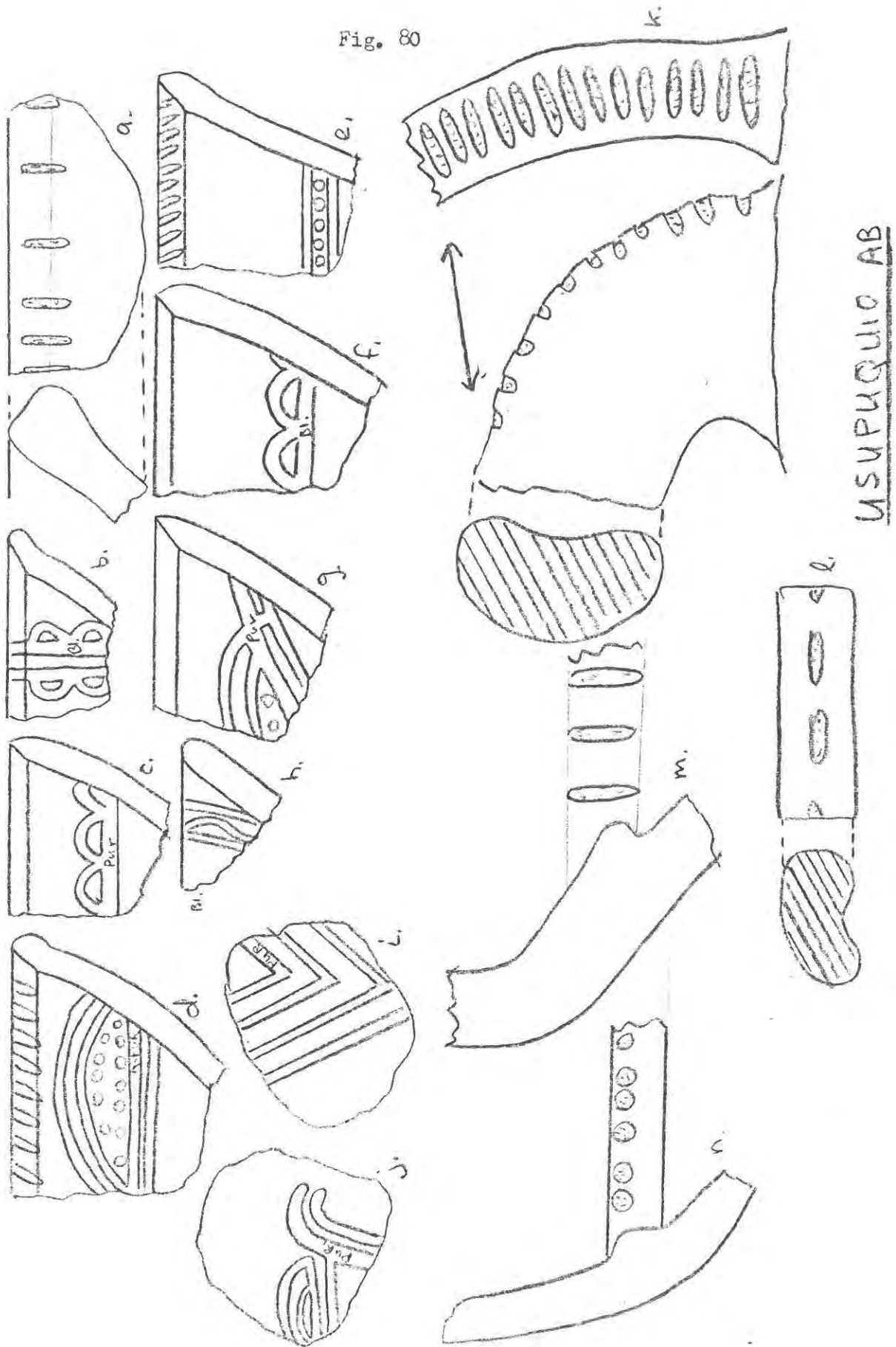
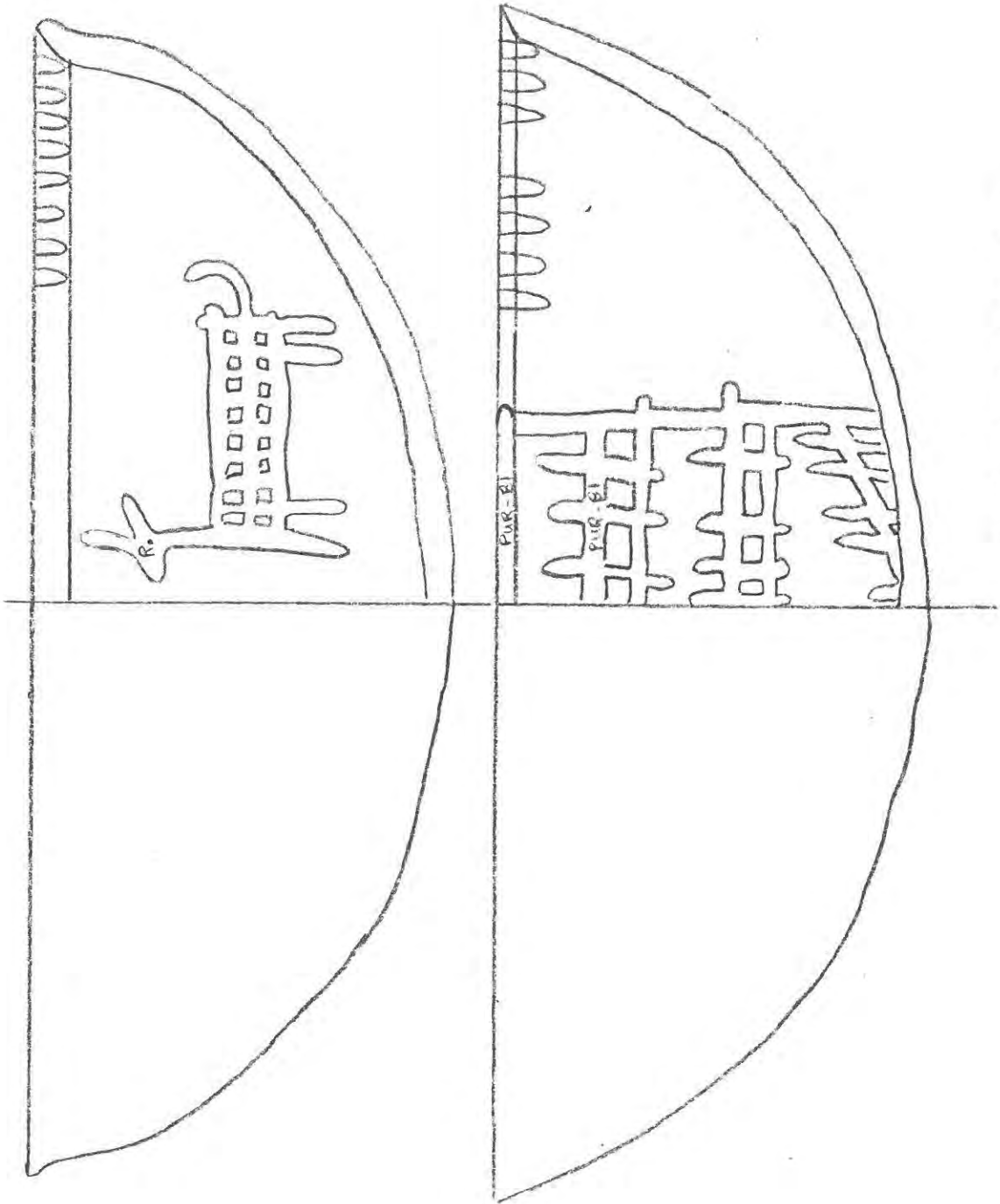
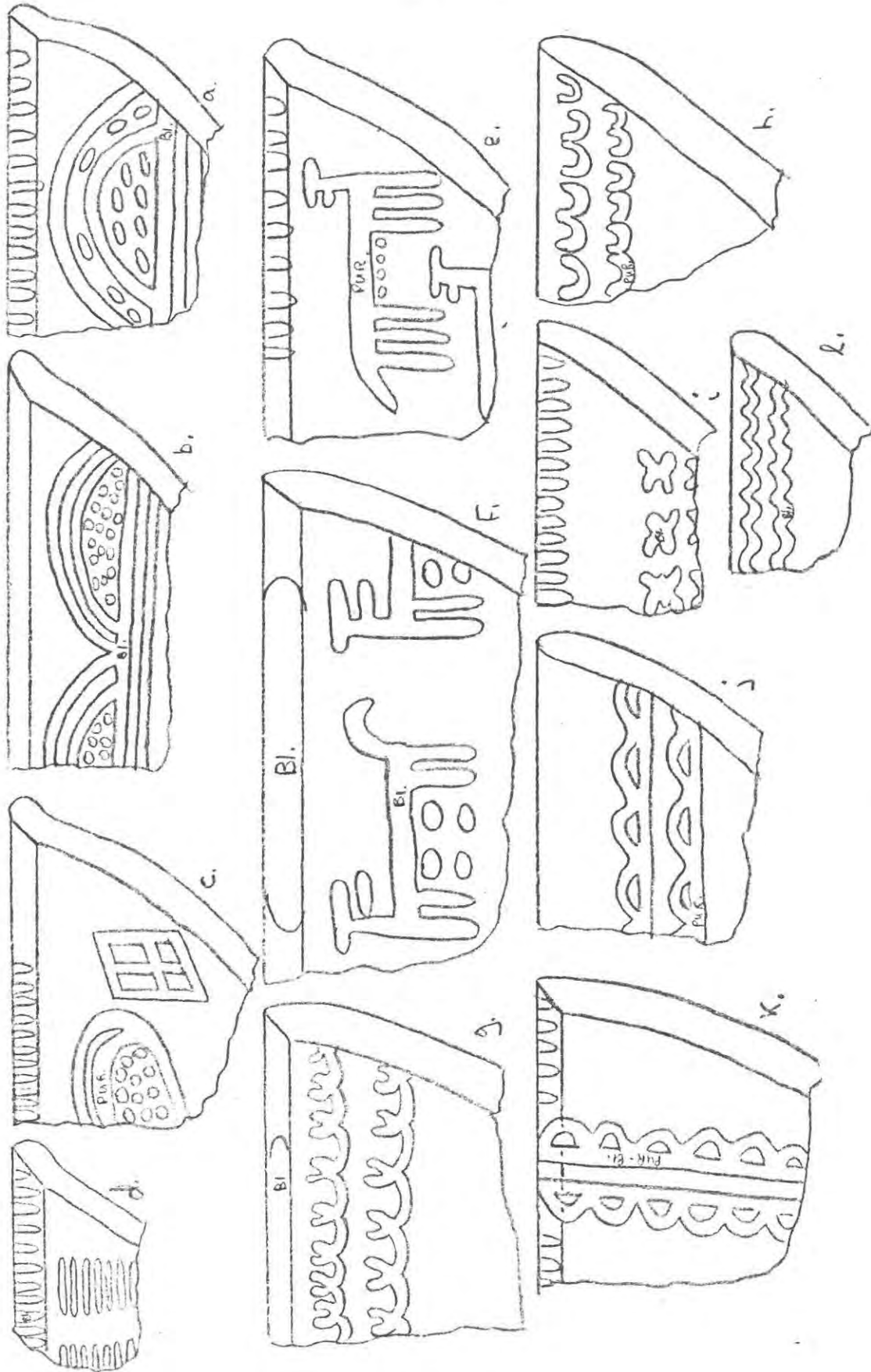

Fig. 81



USUPUQUIC AB

Fig. 82



USU PUQUIMO C

Fig. 83

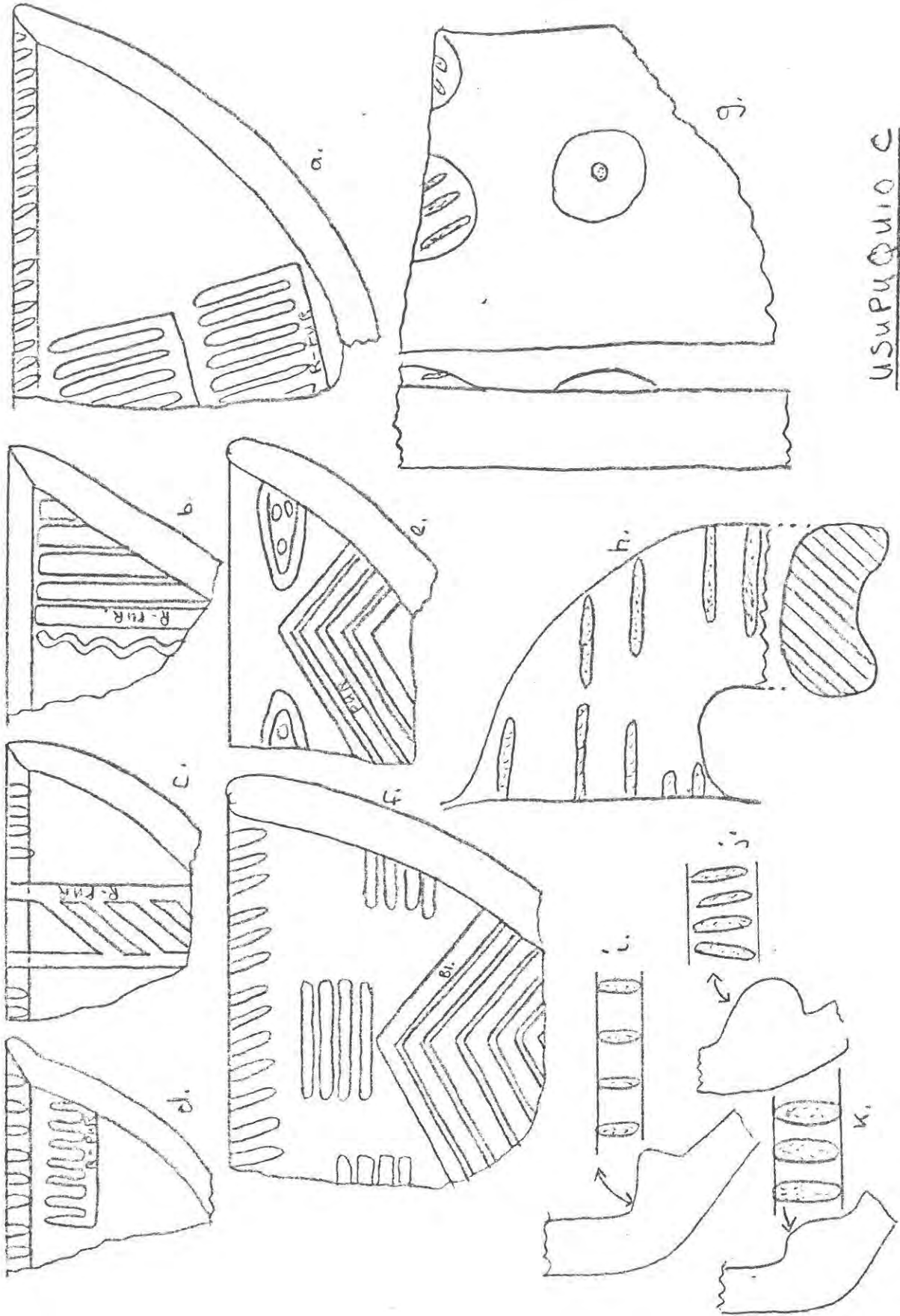

USUPUQUIO C

Fig. 84

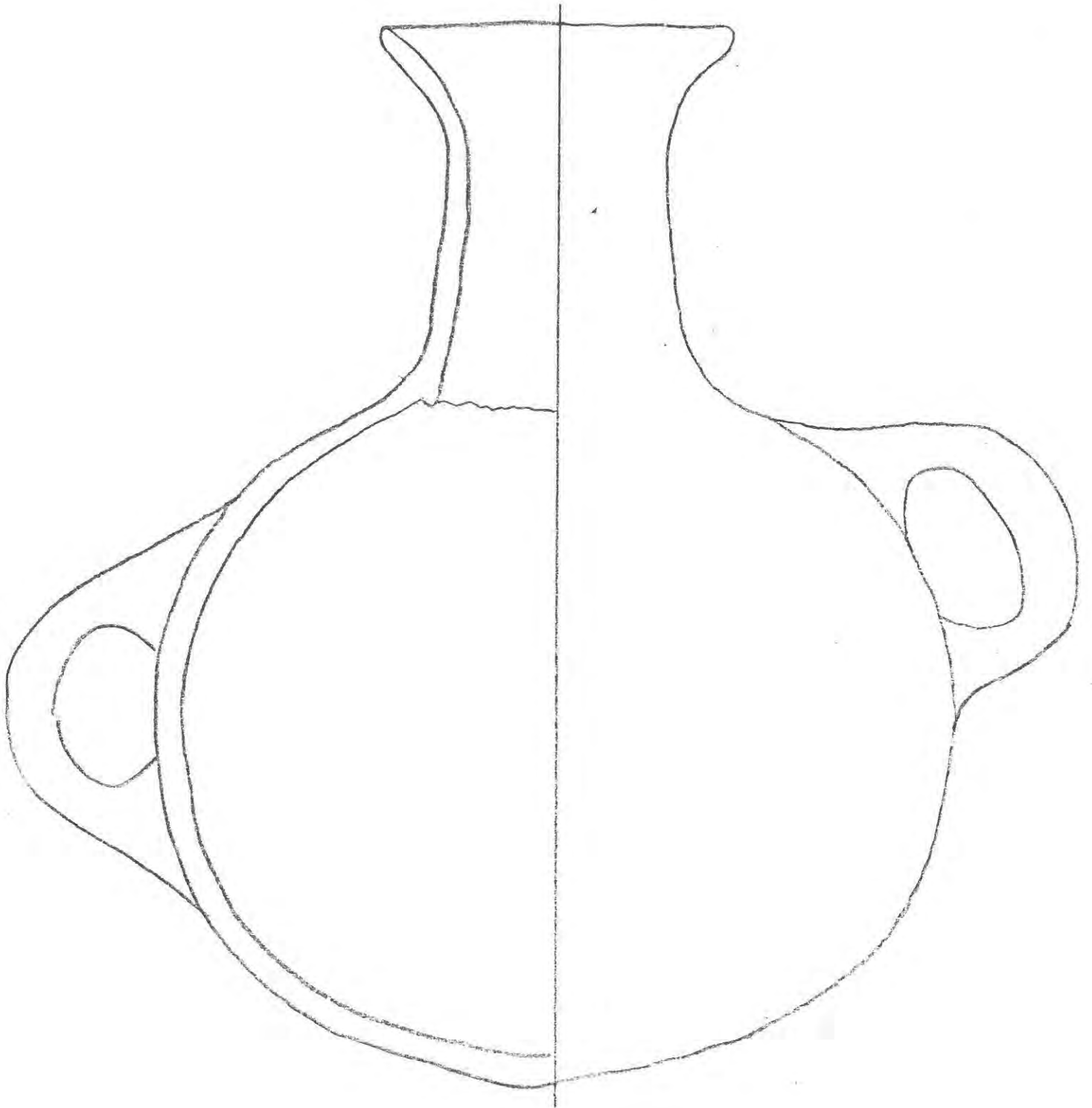

MSYPHQWIO D

PJUM 677-?, TOMB 7

Fig. 85

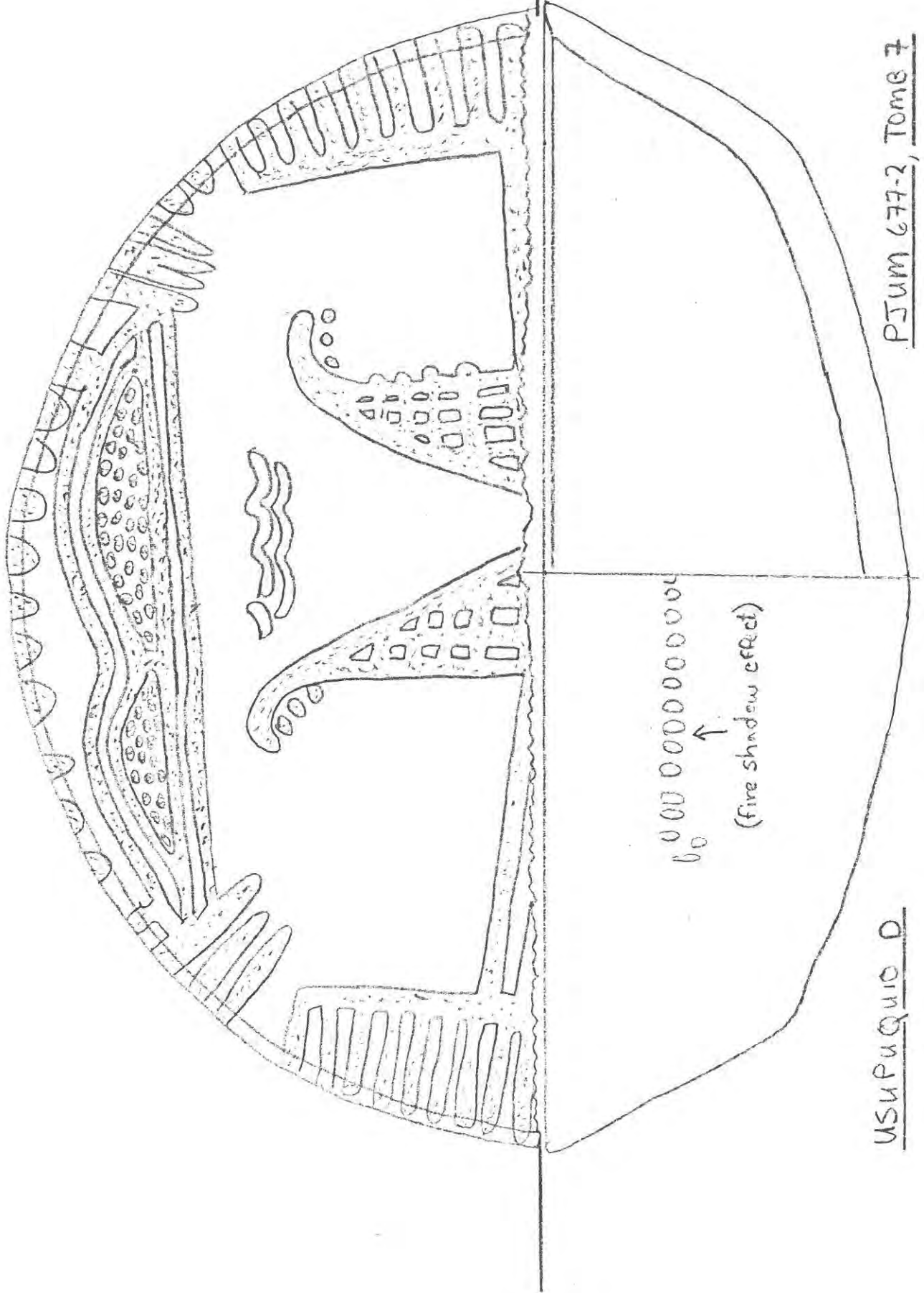

USUPUQUID O

PJUM 677-2, Tome 7

↑
(fire shadow effect)

Fig. 86

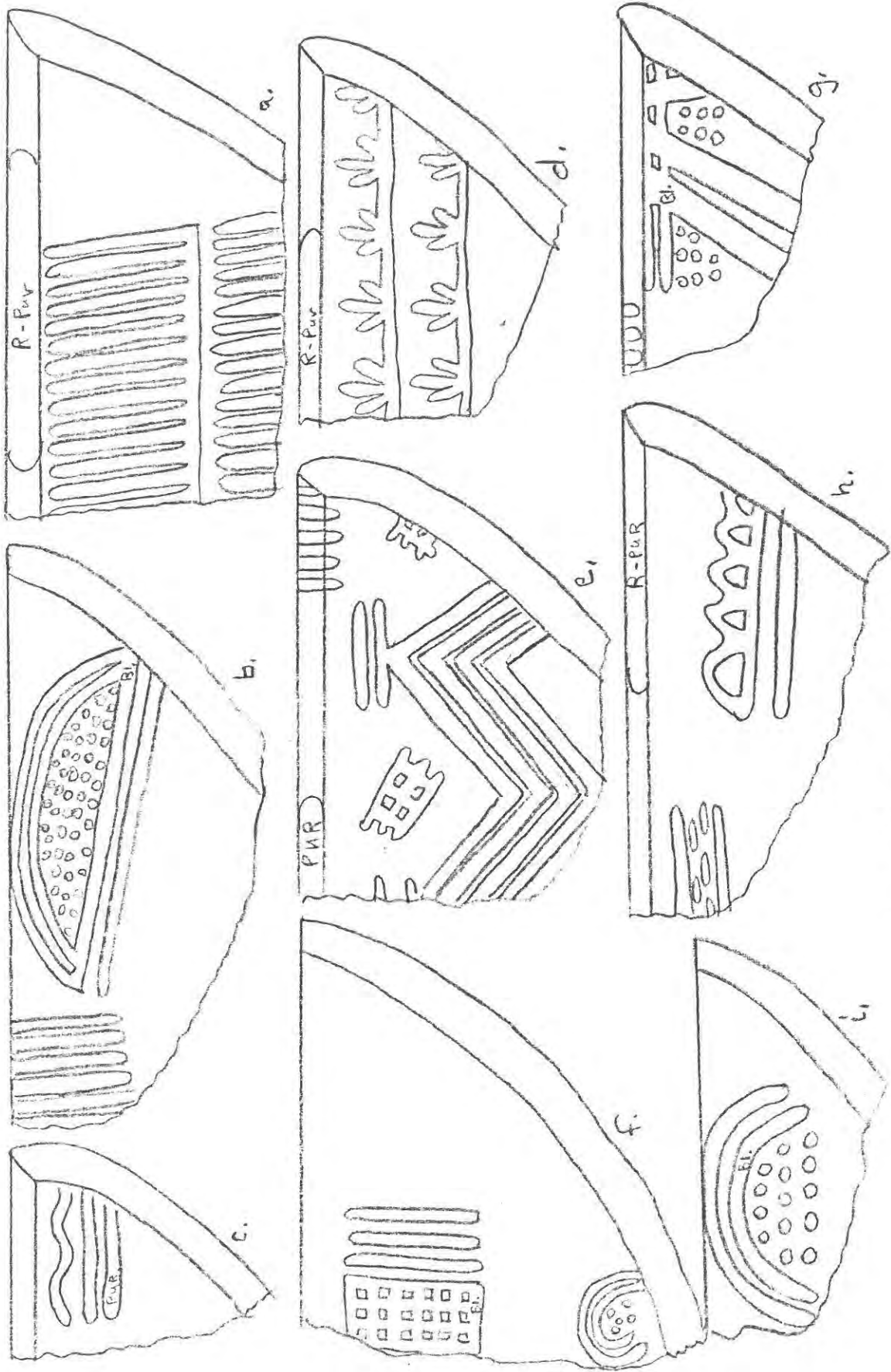

USUPUQUID D

Fig. 87

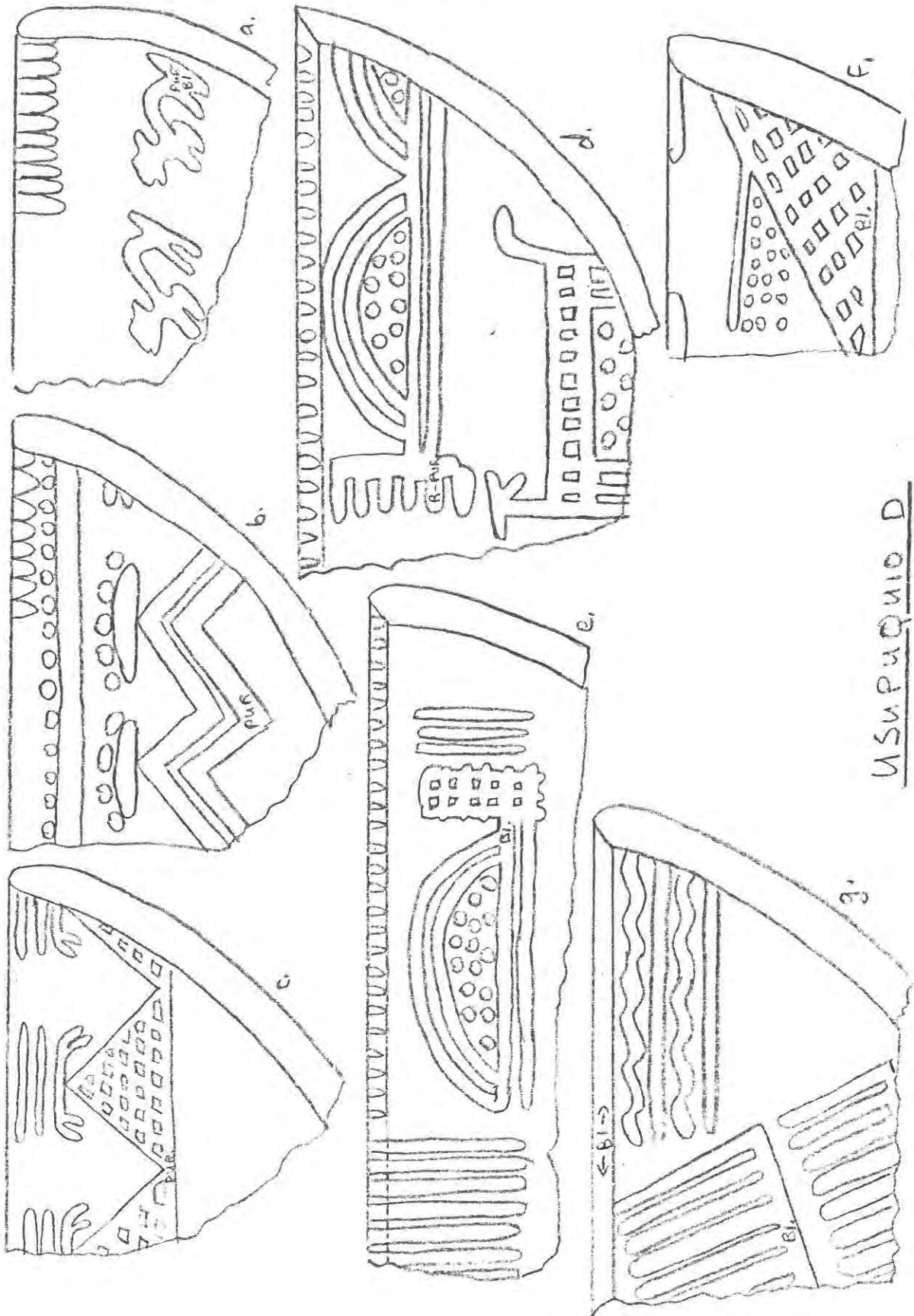

USUPUQUIO D

Fig. 88

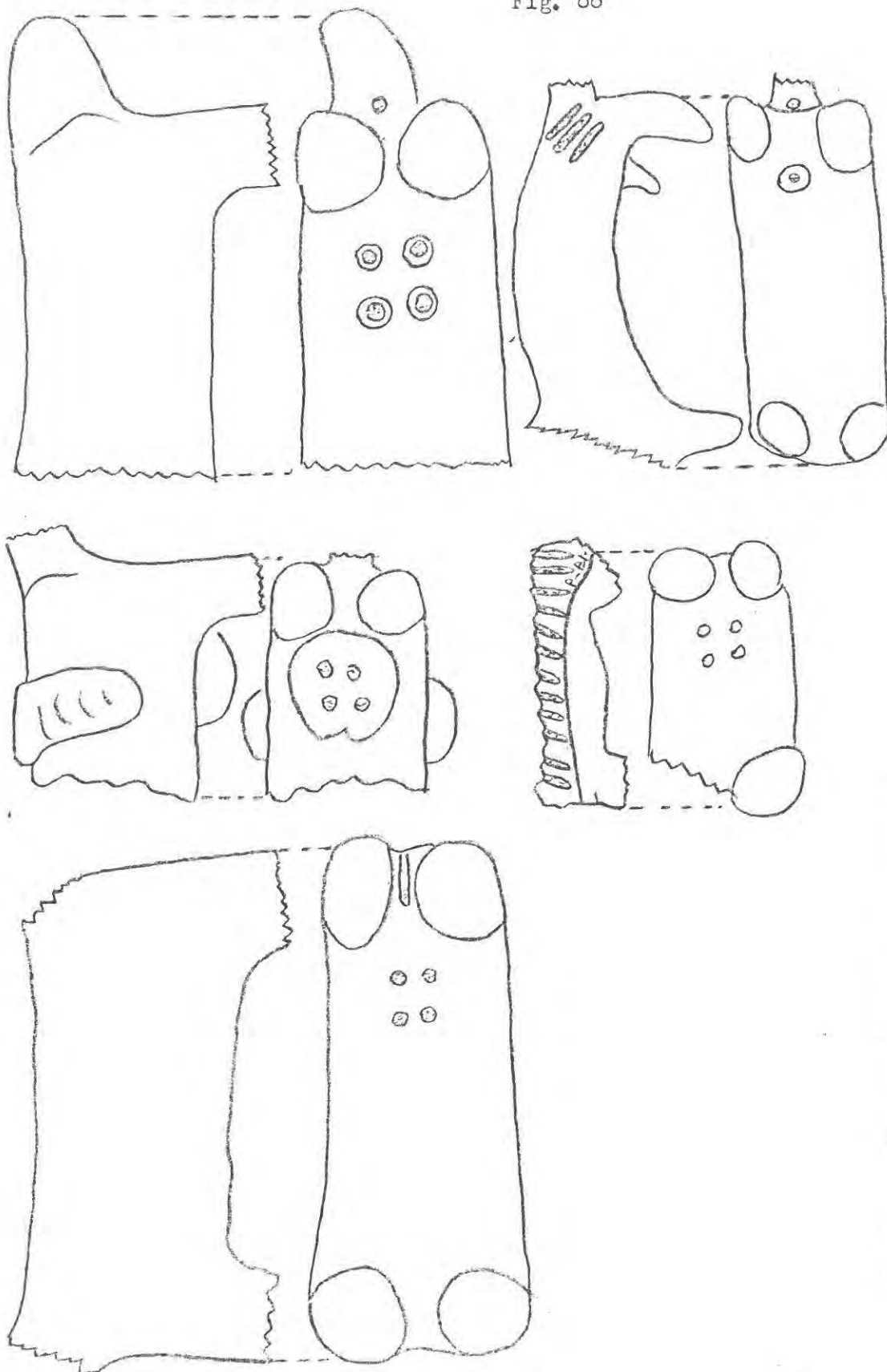

USUPUQUIO C-D-E LLAMAS

Fig. 89

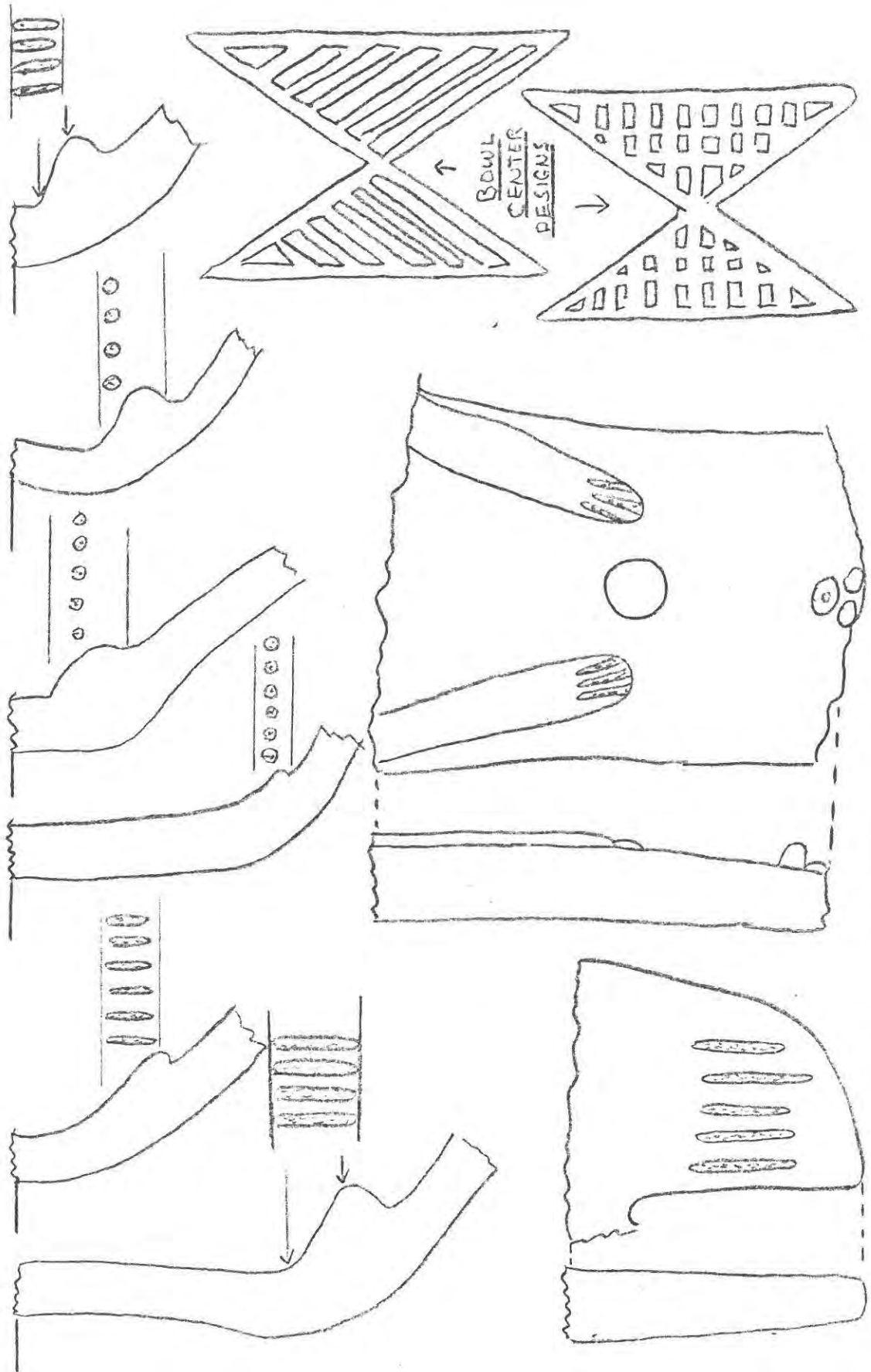

USUPUQUIO D

Fig. 90

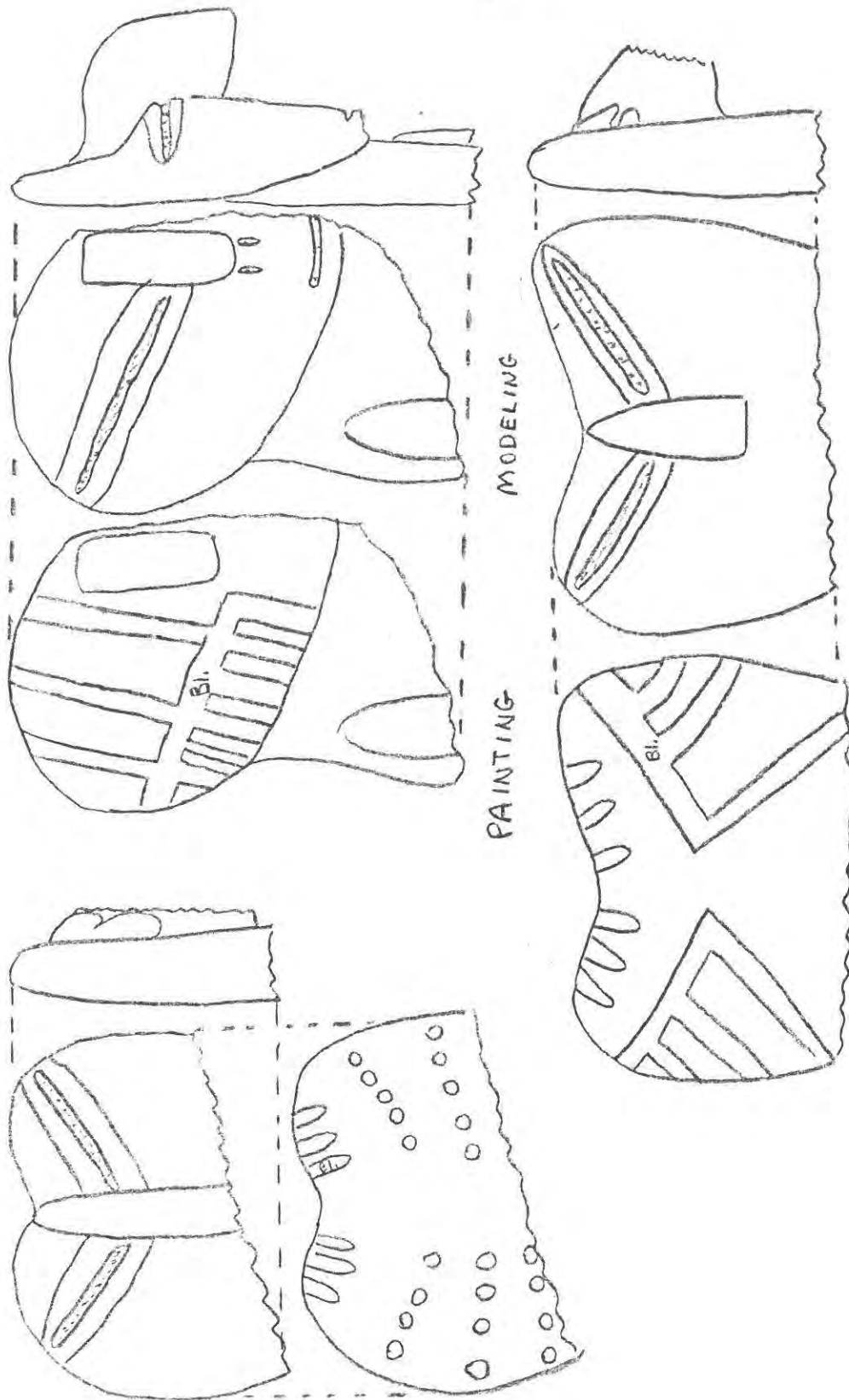

USYPUQUIO D

Fig. 91

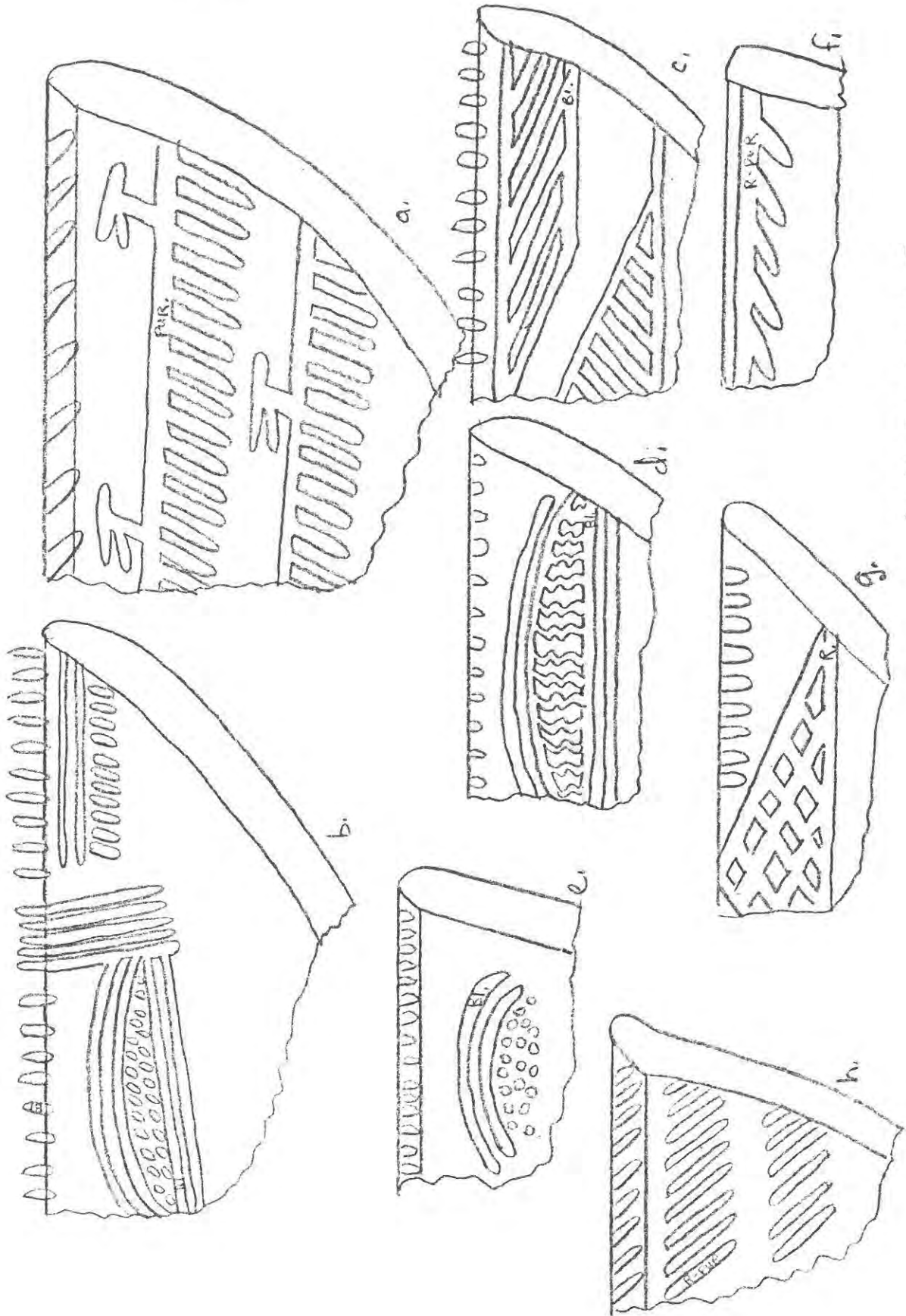

USUPUQUIO E

Fig. 93

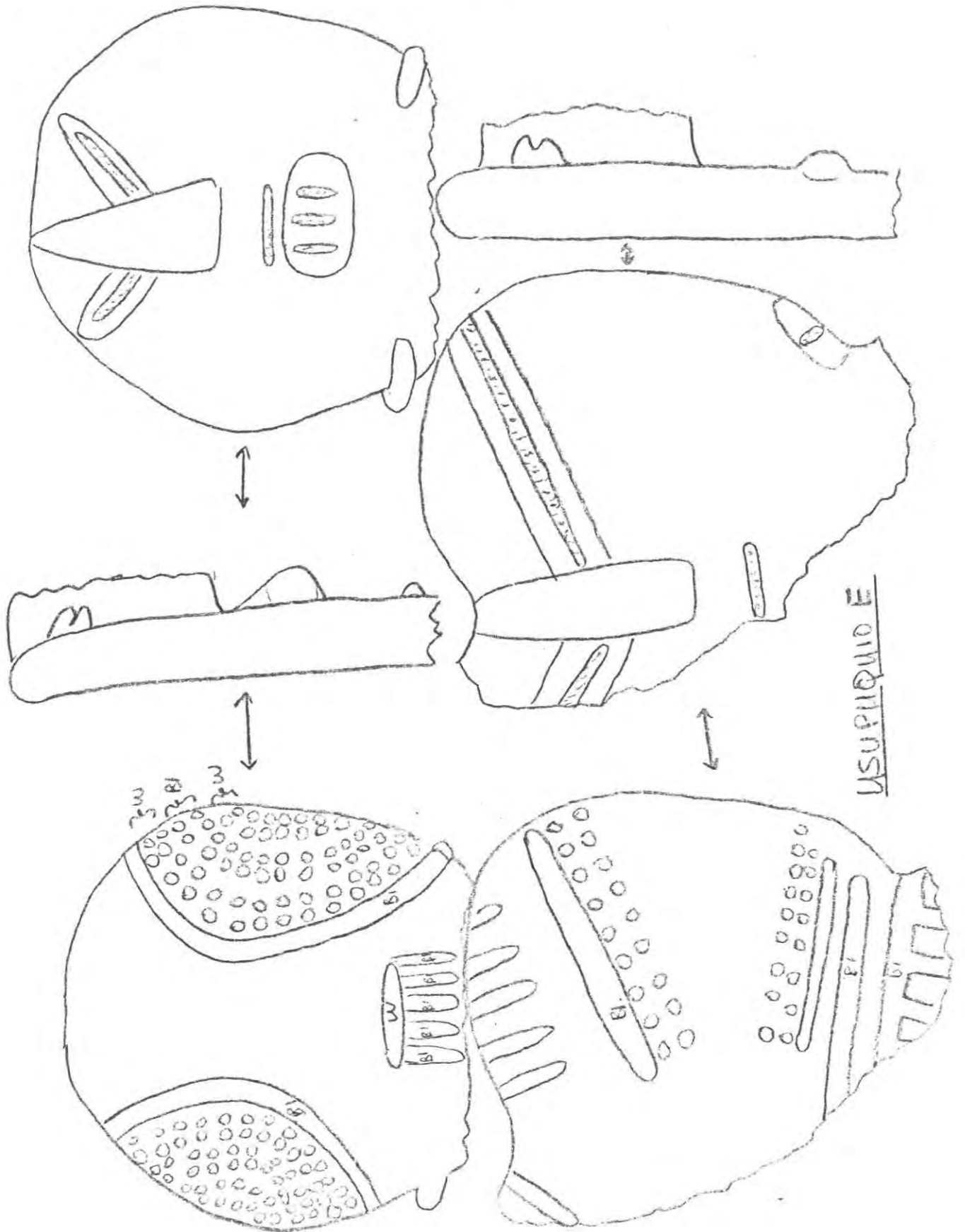
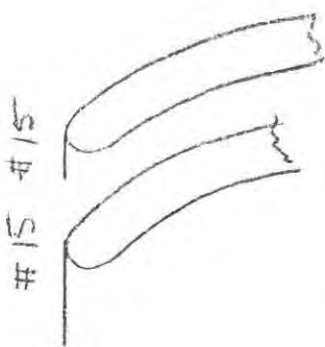
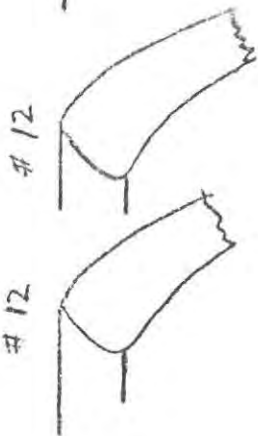
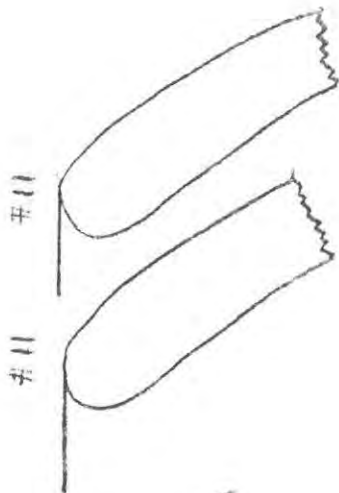

Fig. 94



OLLAS

ENCLOSED BOWL



LID

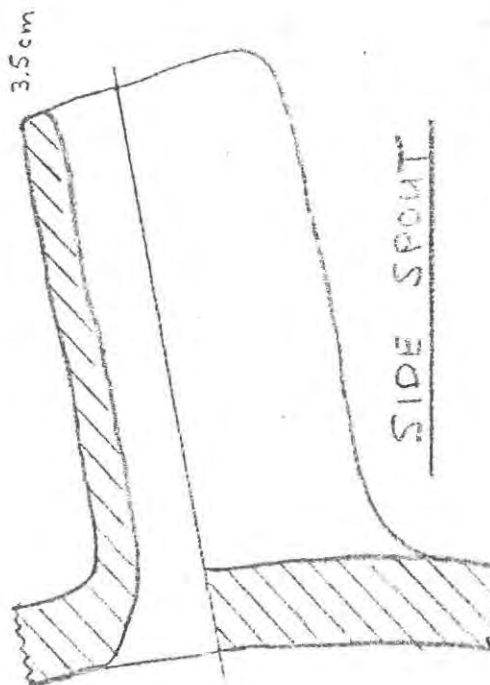

SIDE SPOUT

HUACRAPUQUID - VARIOUS

Fig. 95

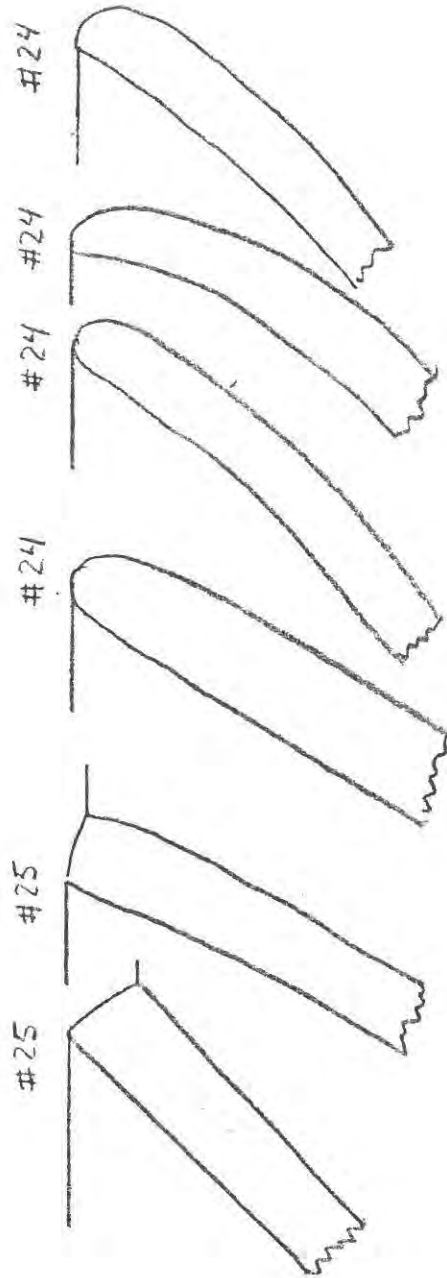
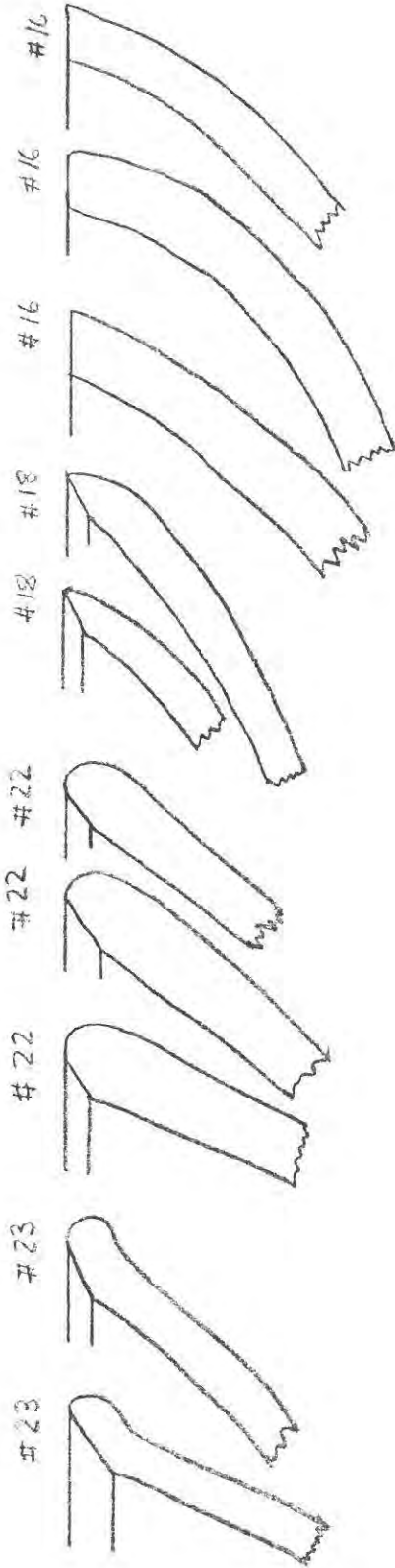

HUACRAPUQUIO OPEN BOWLS

Fig. 97

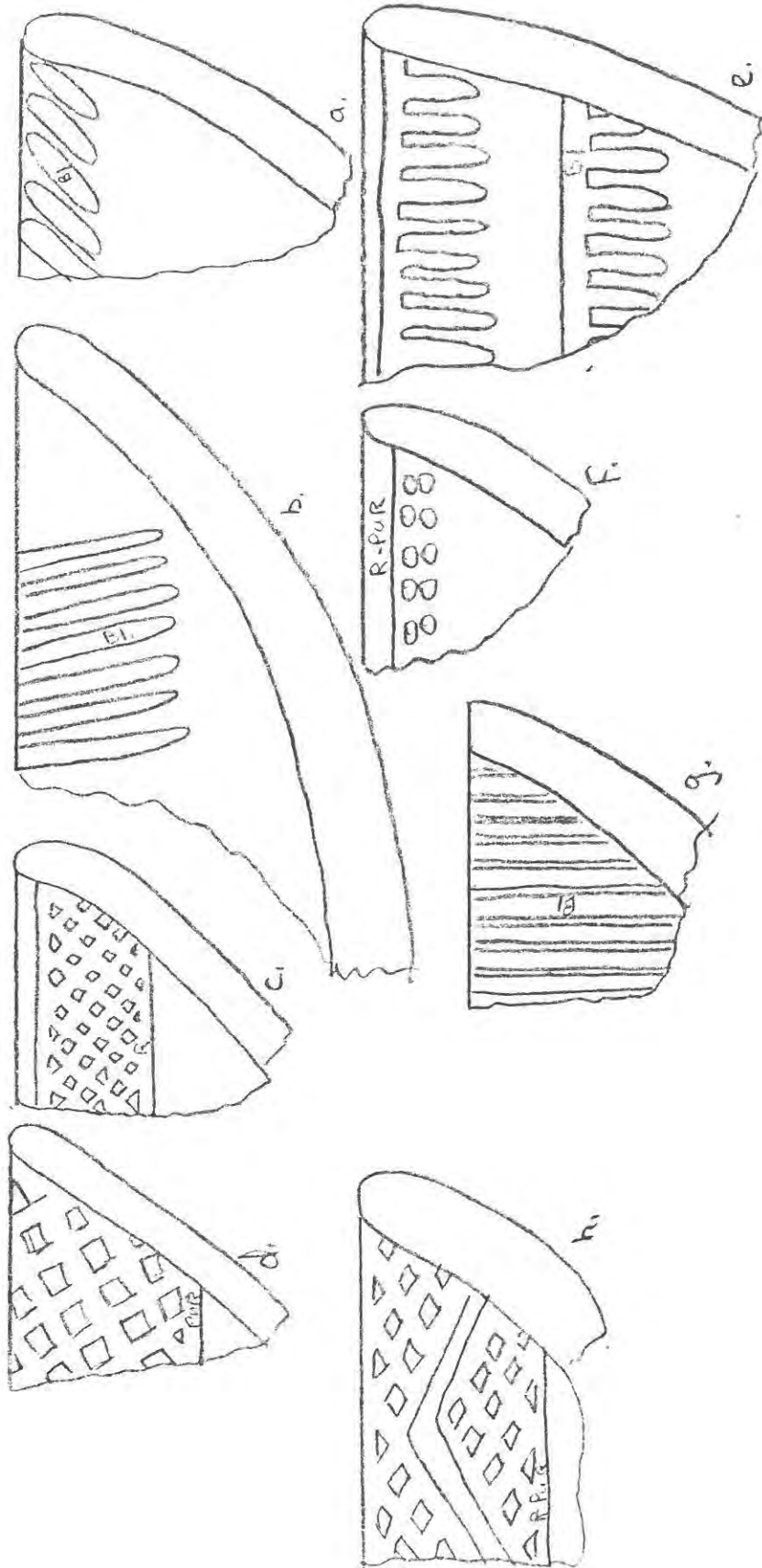

HUACRAPUQUIO A - USUPUQUIO WARE

Fig. 98

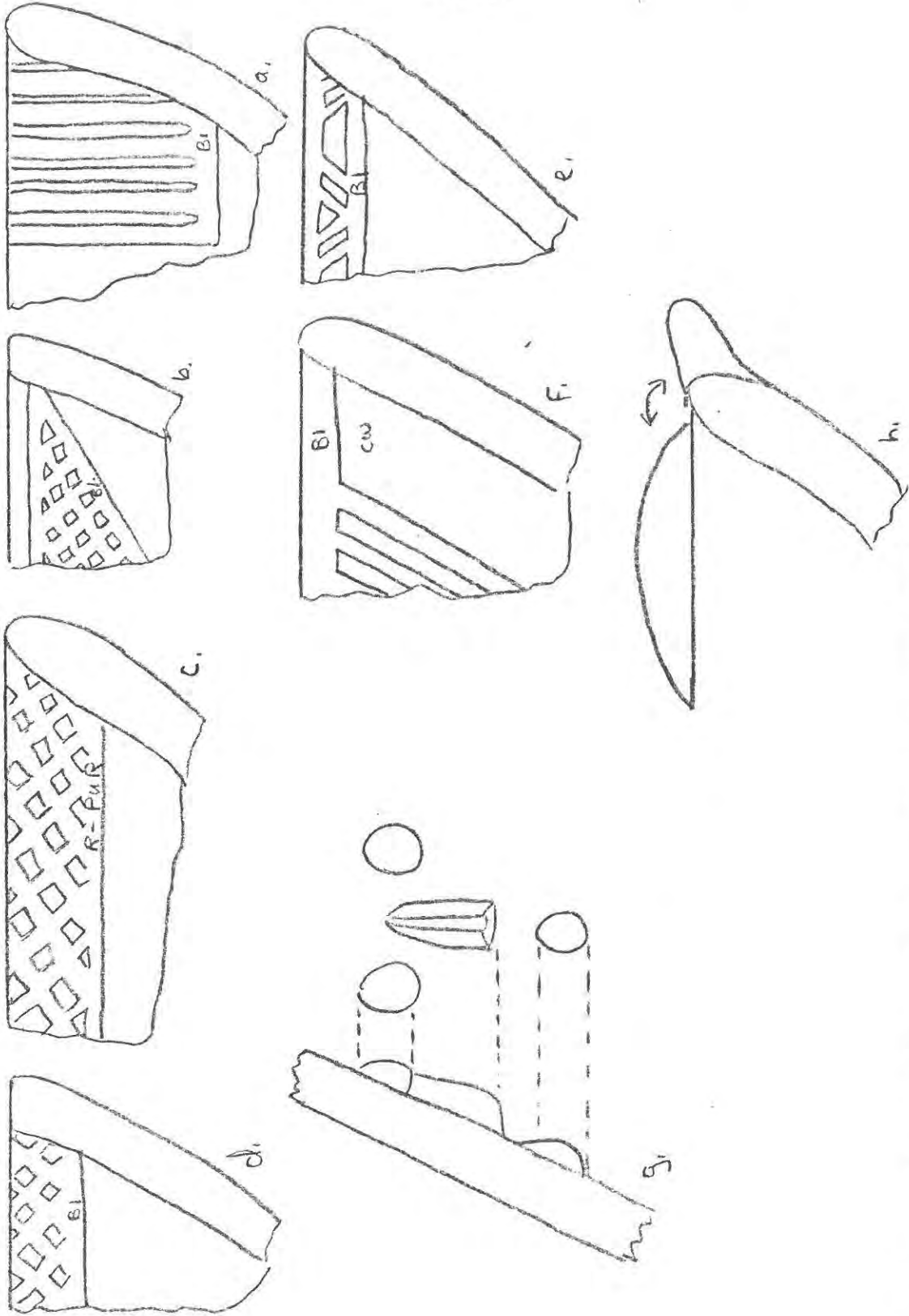

HUACRAPUQUIO A - HUACRAPUQUIO WARE

Fig. 99

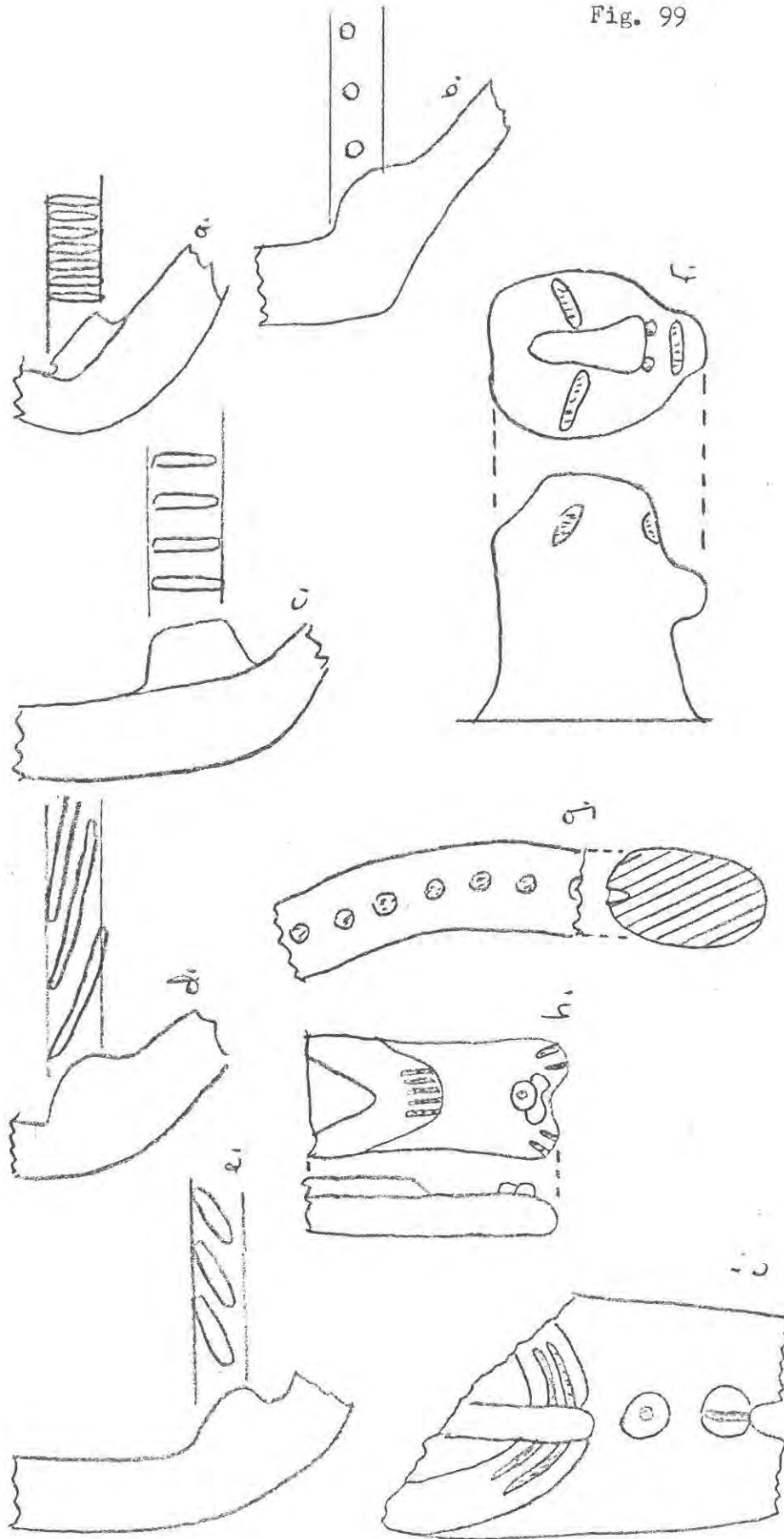

HUACRAPUQUIO A-B

Fig. 101

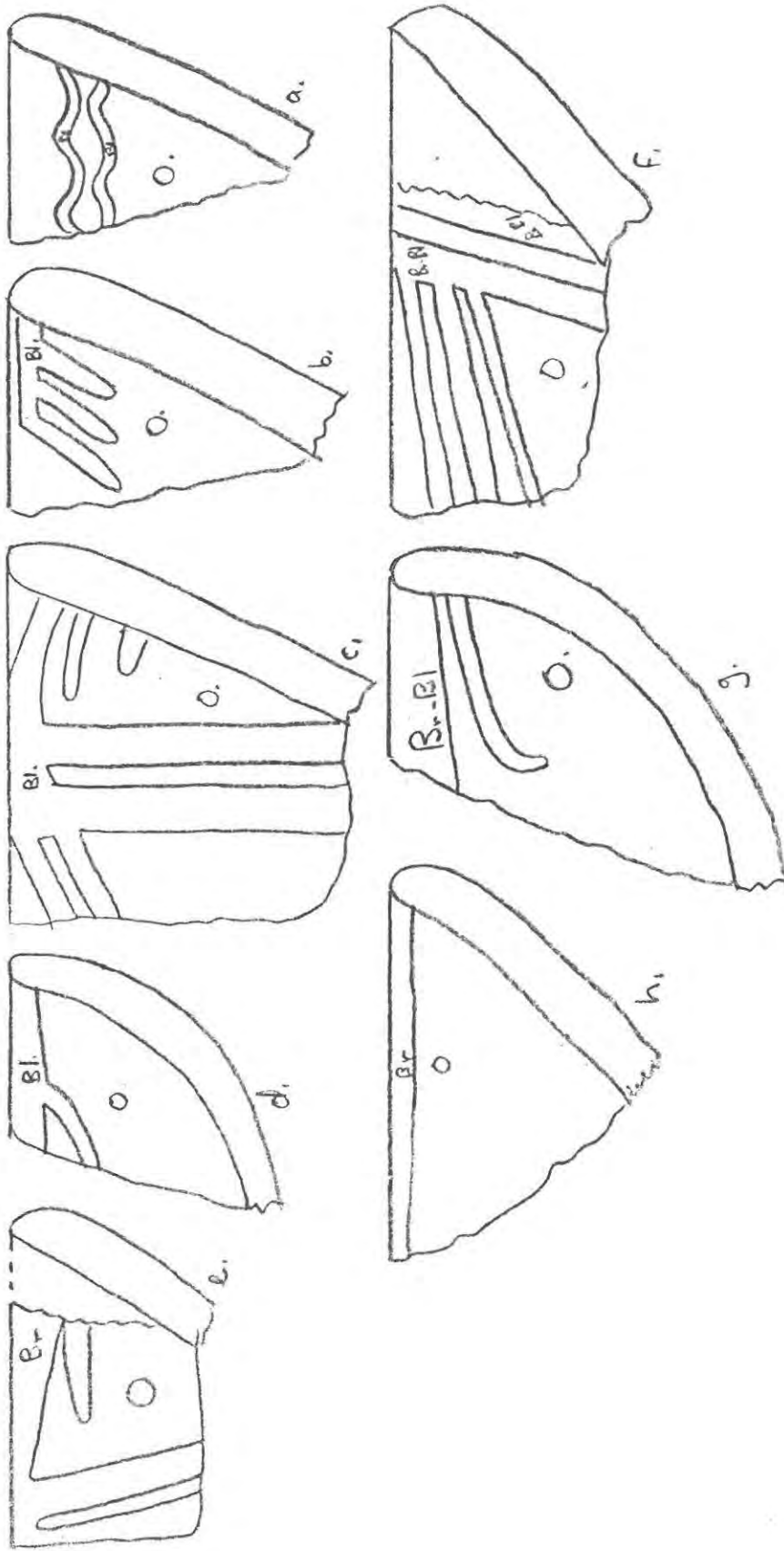

HUACRAPUQUID C - HUACAWATO ORANGE WARE

Fig. 102

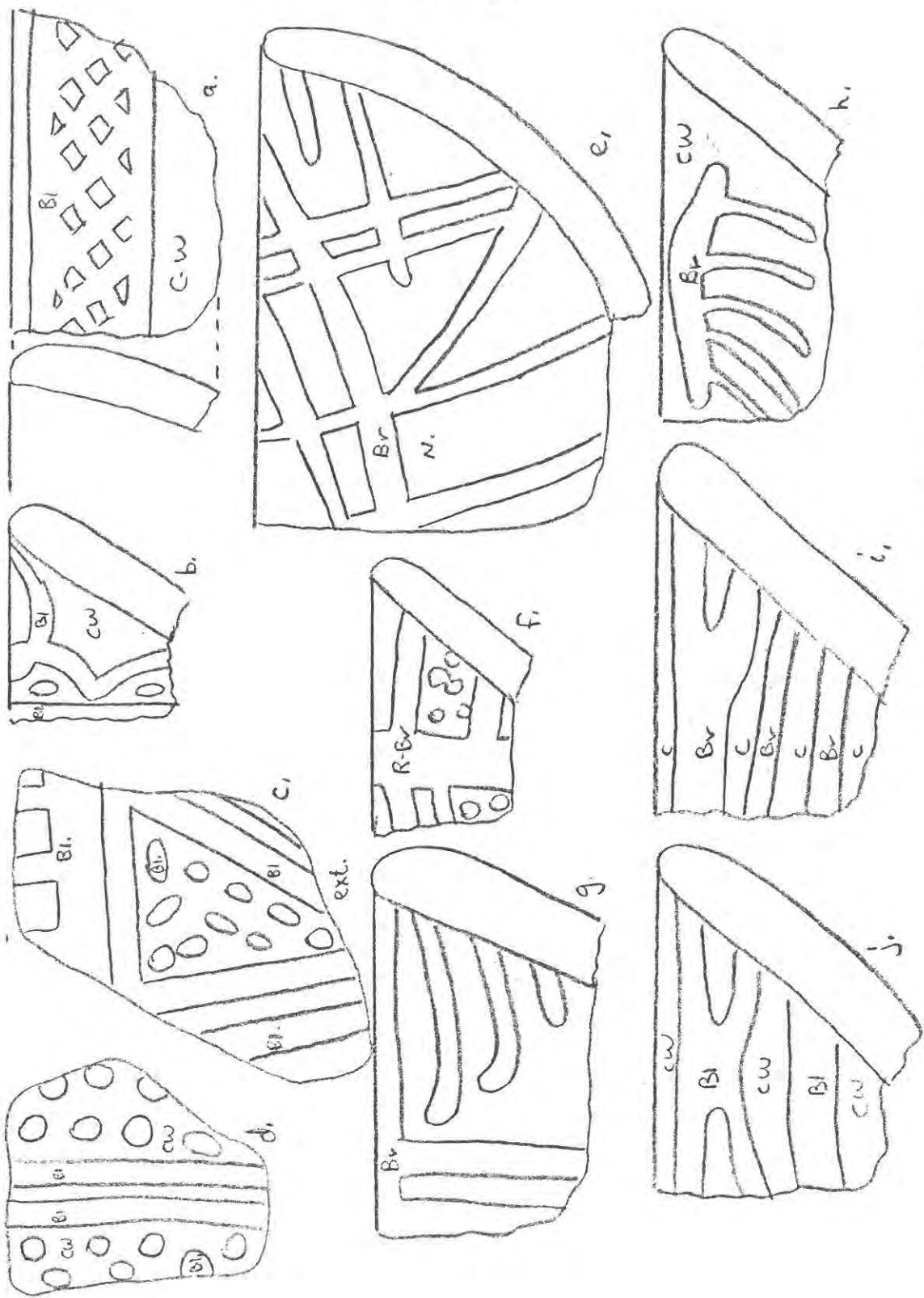

HUACRAPUQUIC

Fig. 103

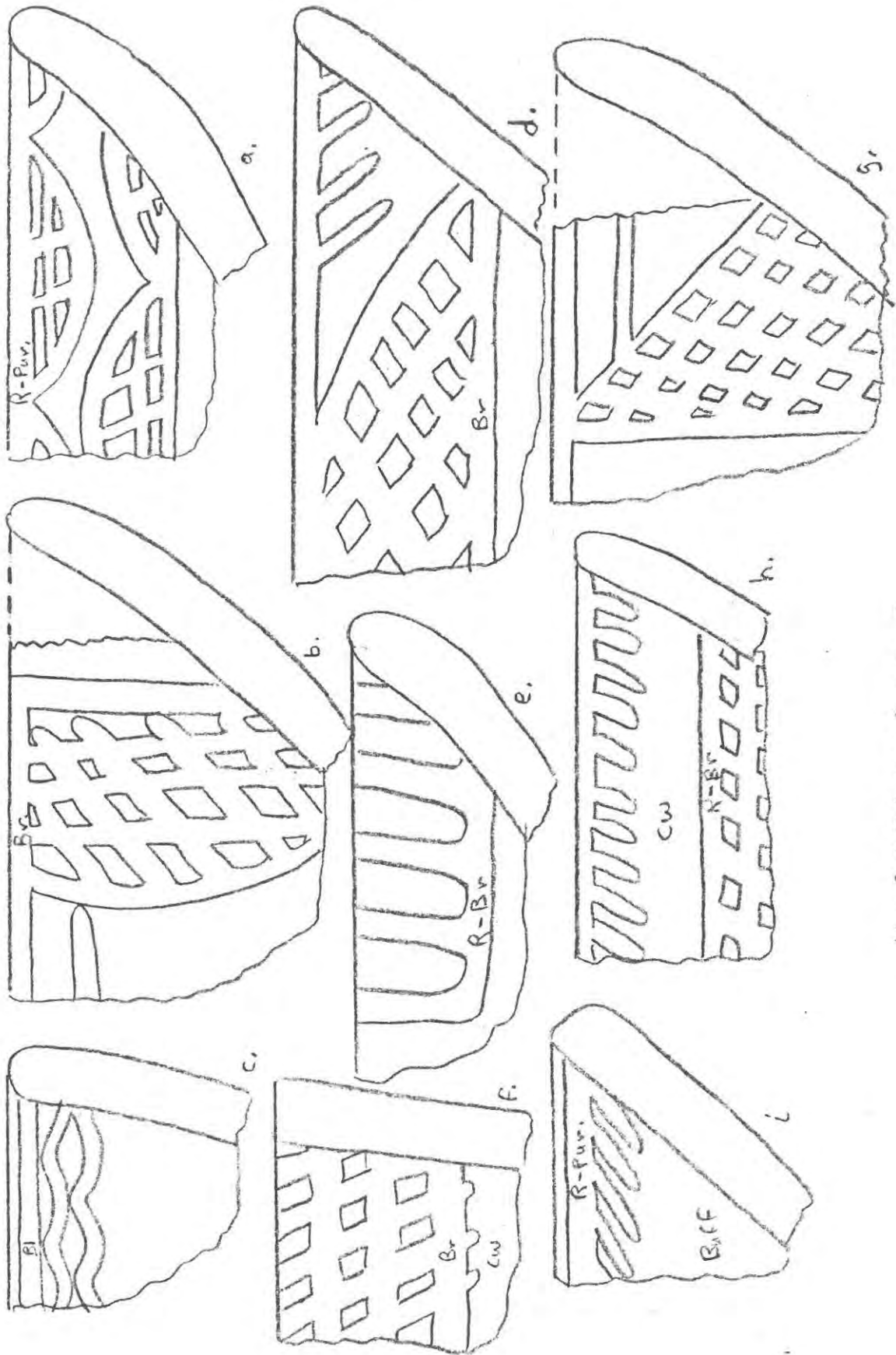

HUACRAPIQUIO C

Fig. 104

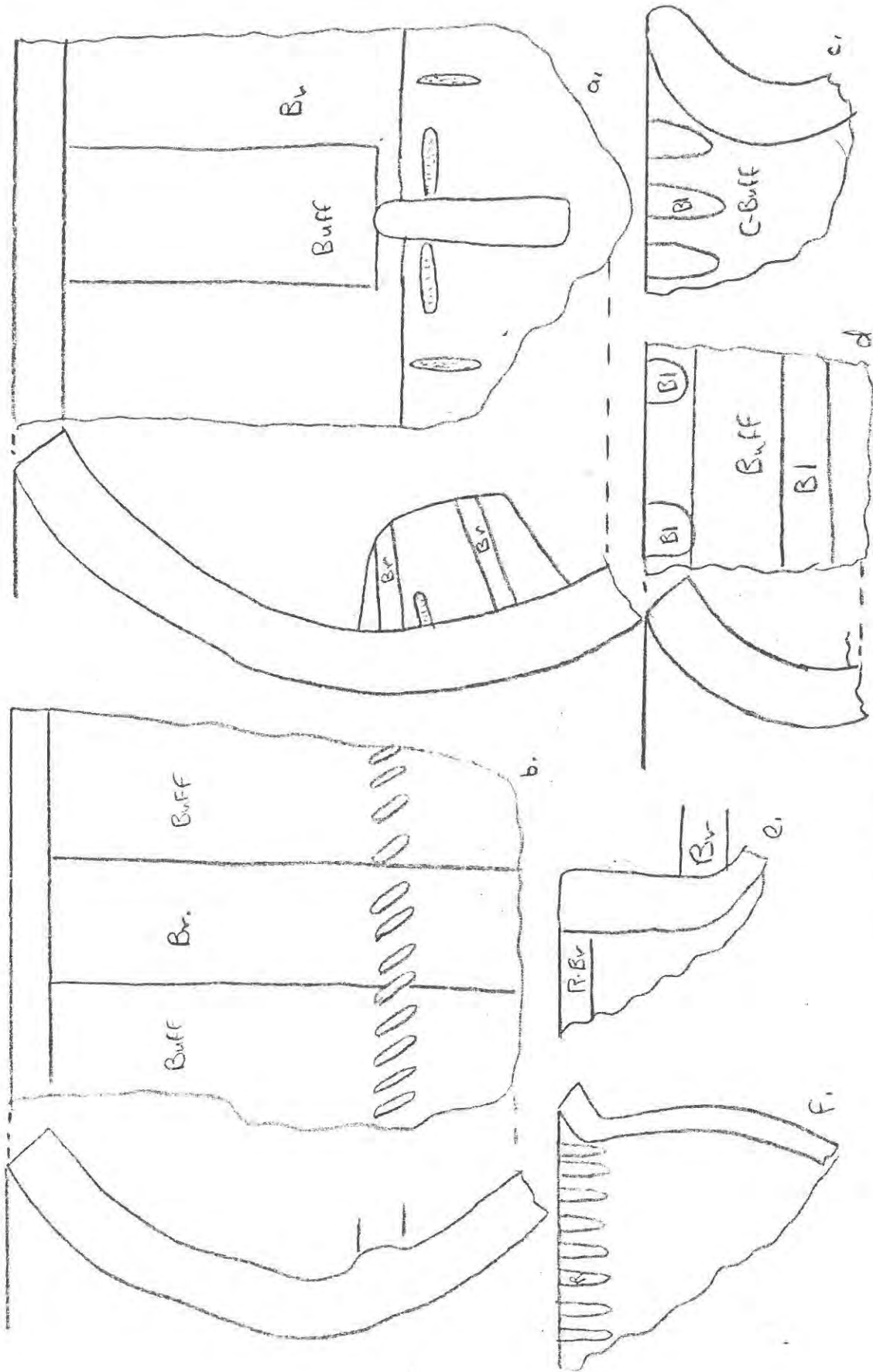

HUACRAPUQUIO C

Fig. 105

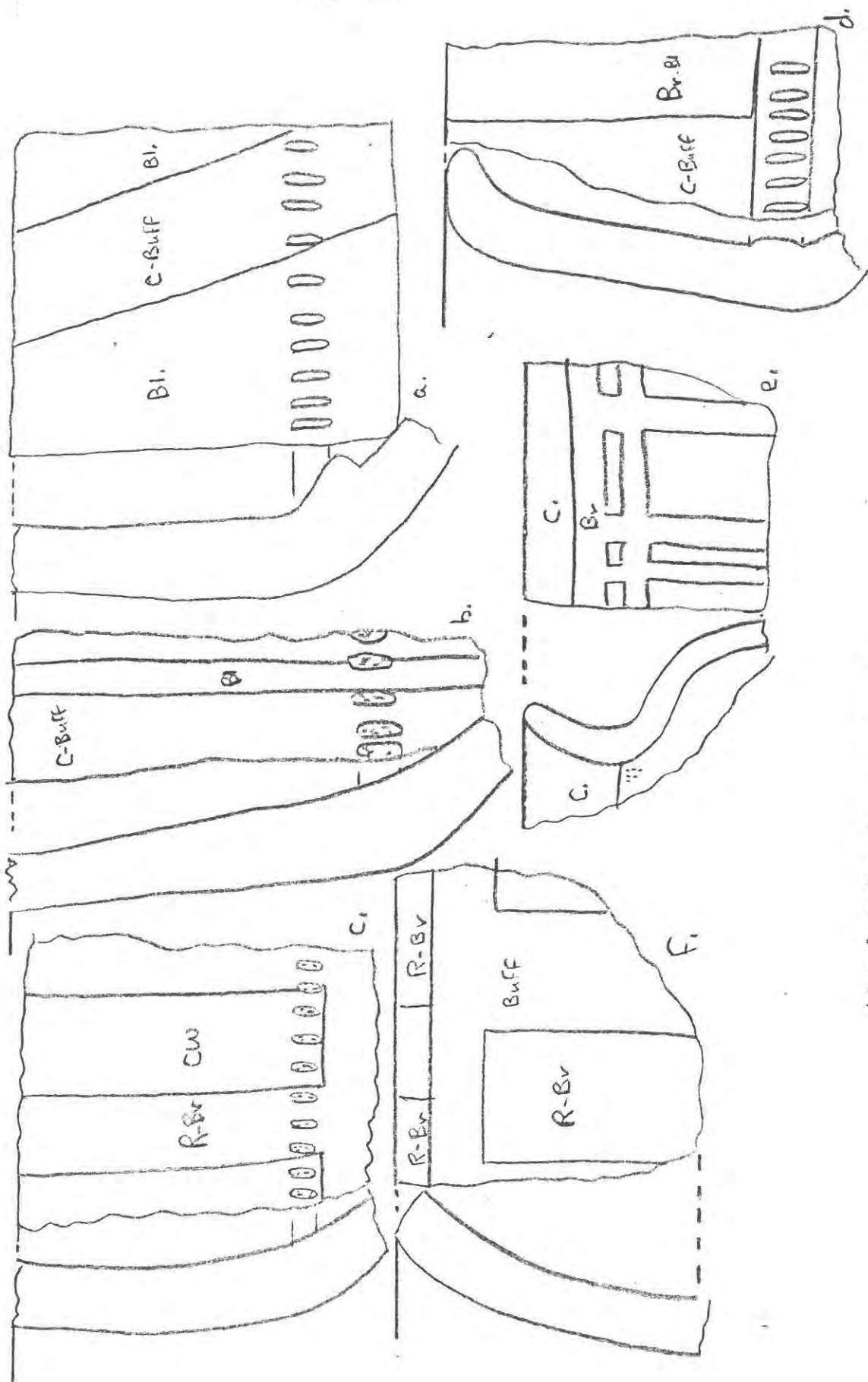

HUACRAPUQUIO C

Fig. 106.

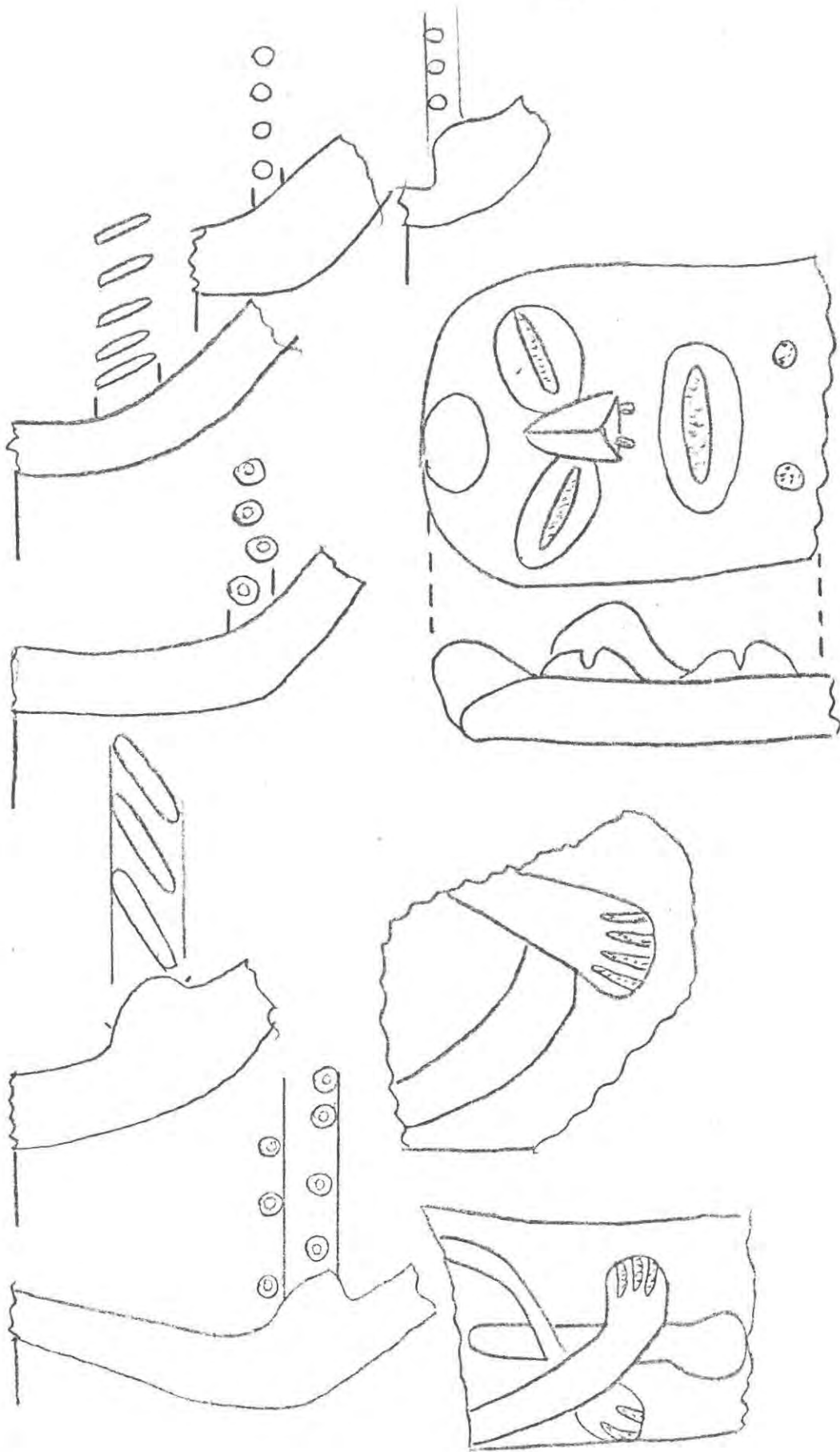

HUACRAPUQUID C

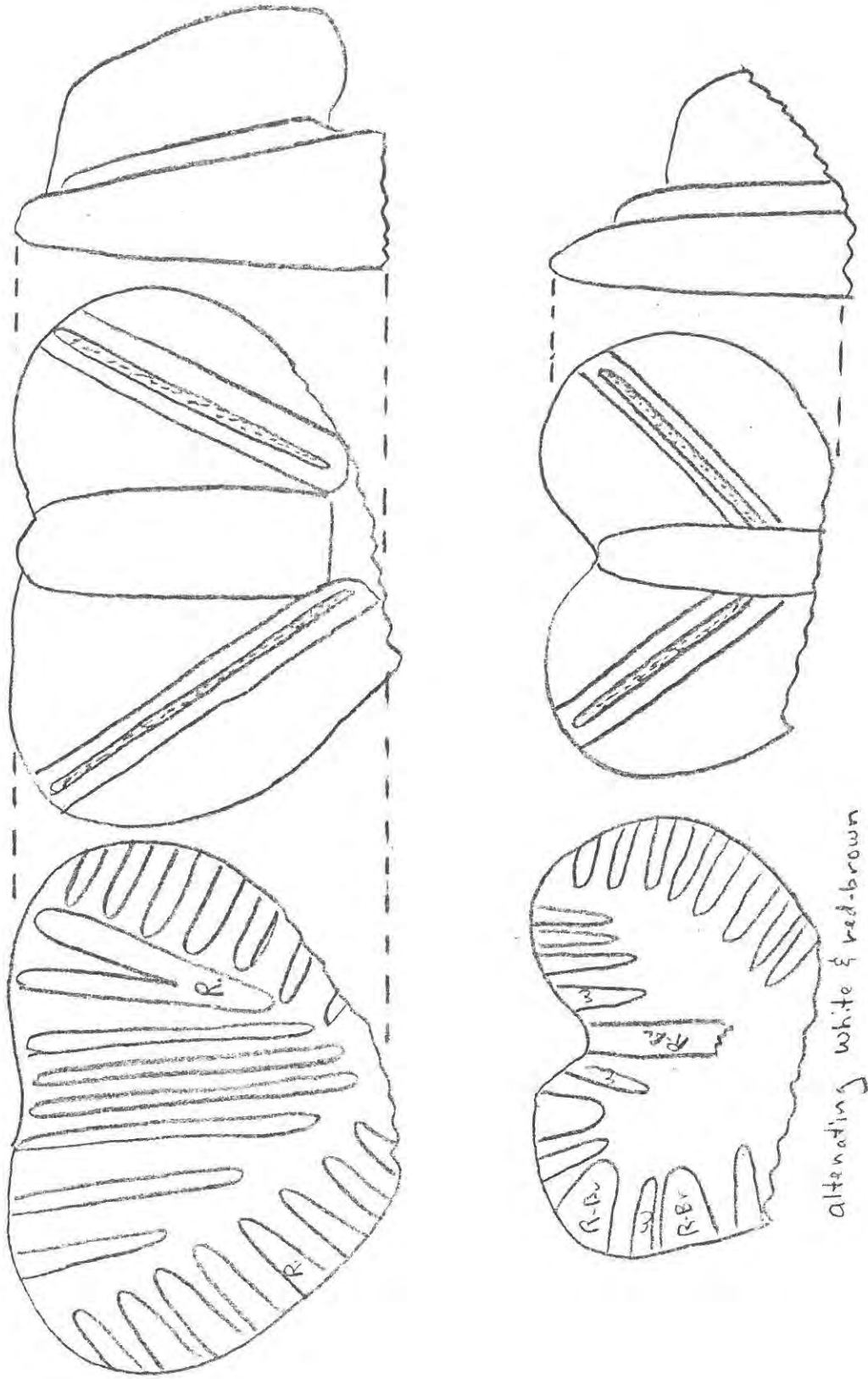

alternating white & red-brown

HUACRAPUQUIC C.

Fig. 108

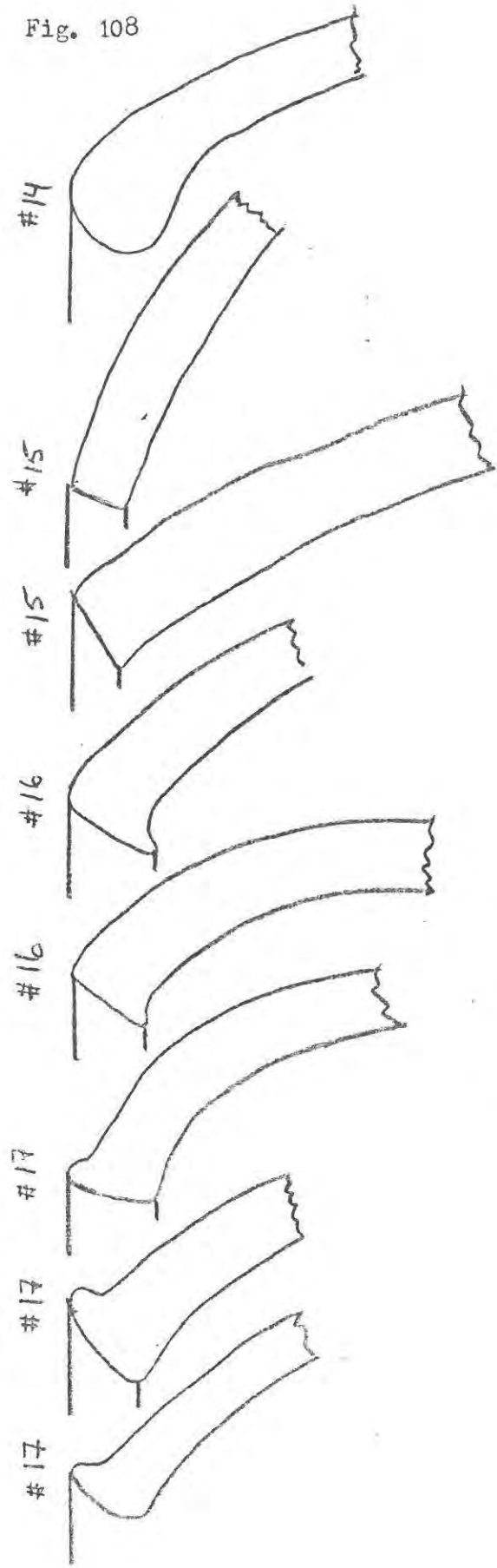
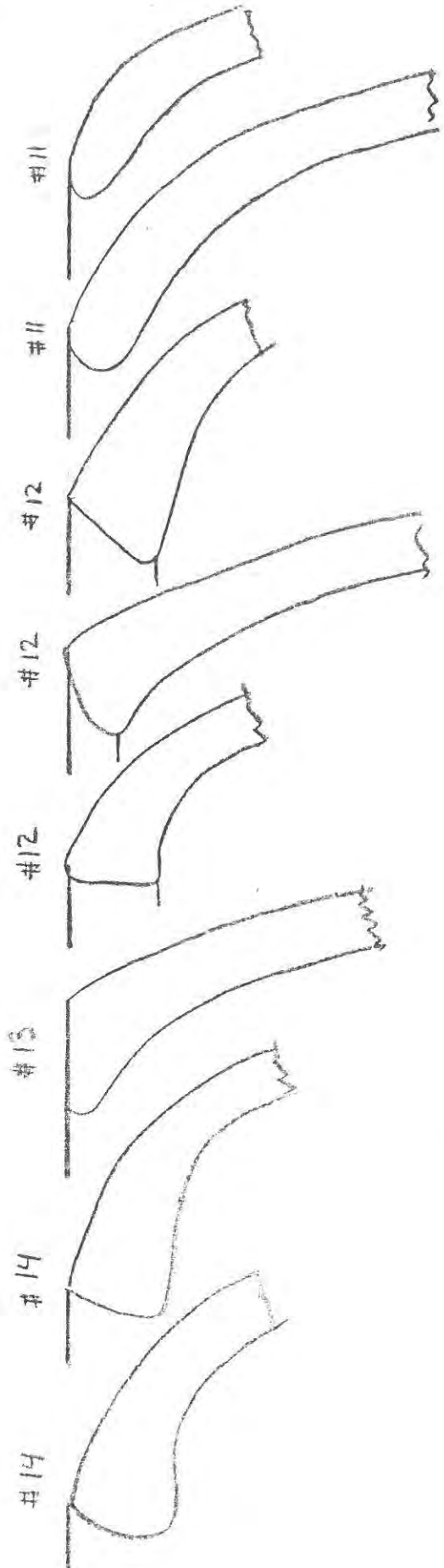

CALPISH OLLAS

Fig. 109

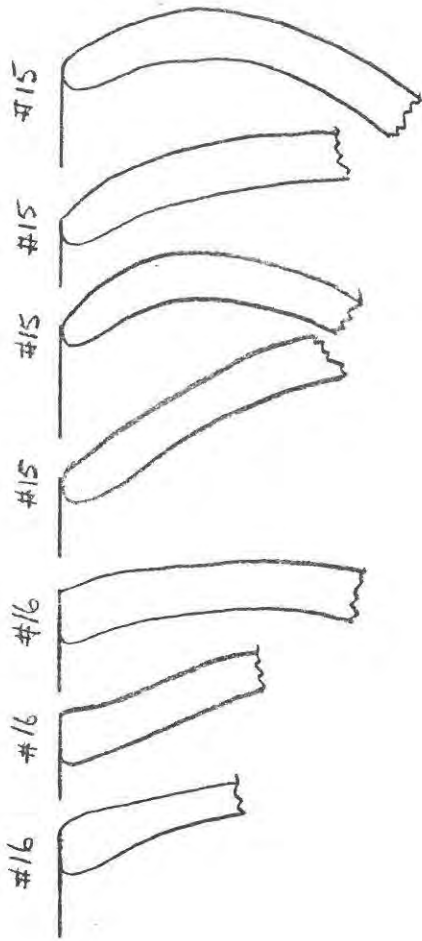

CALPISH

Fig. 110

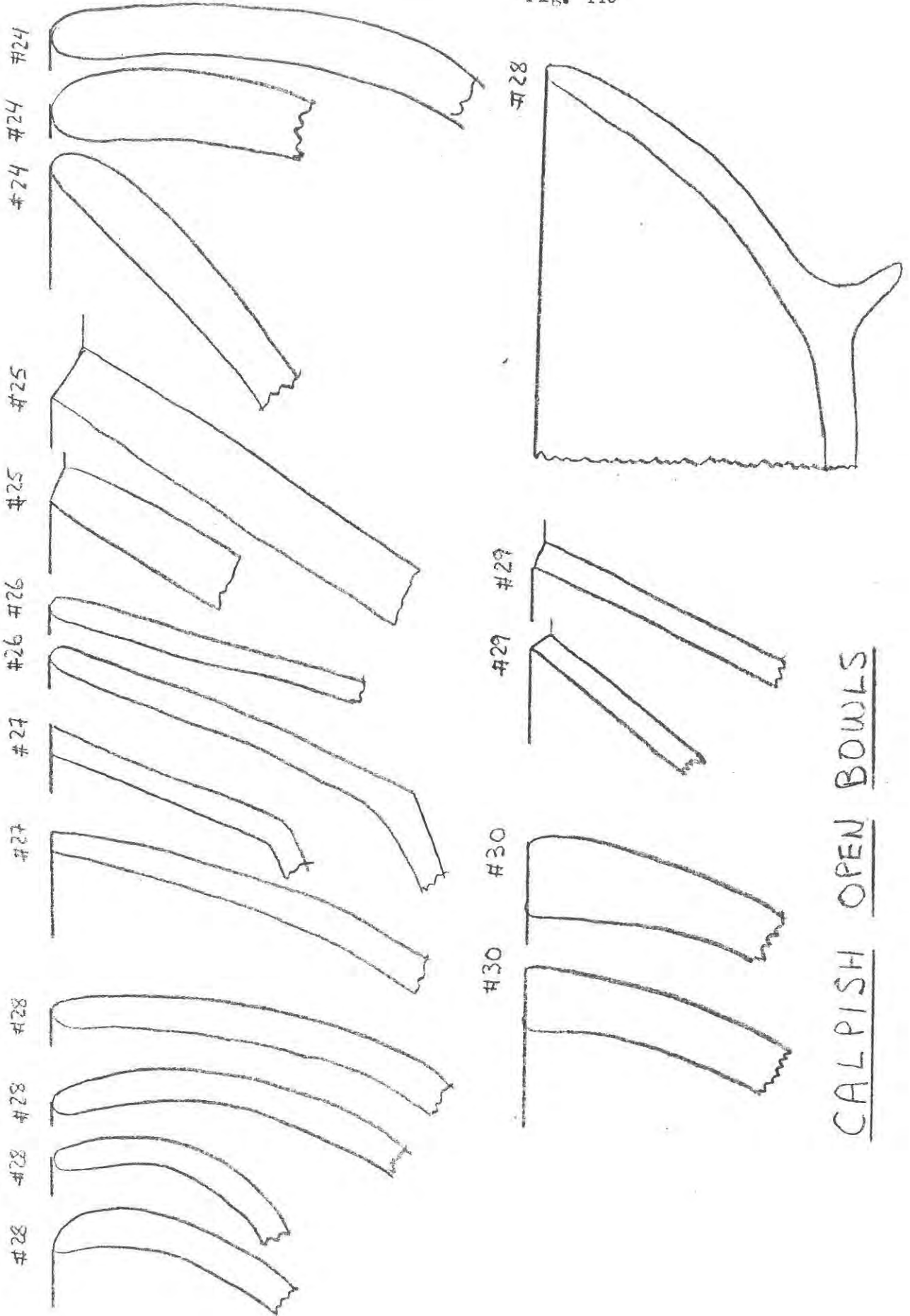

CALPISH OPEN BOWLS

Fig. 111

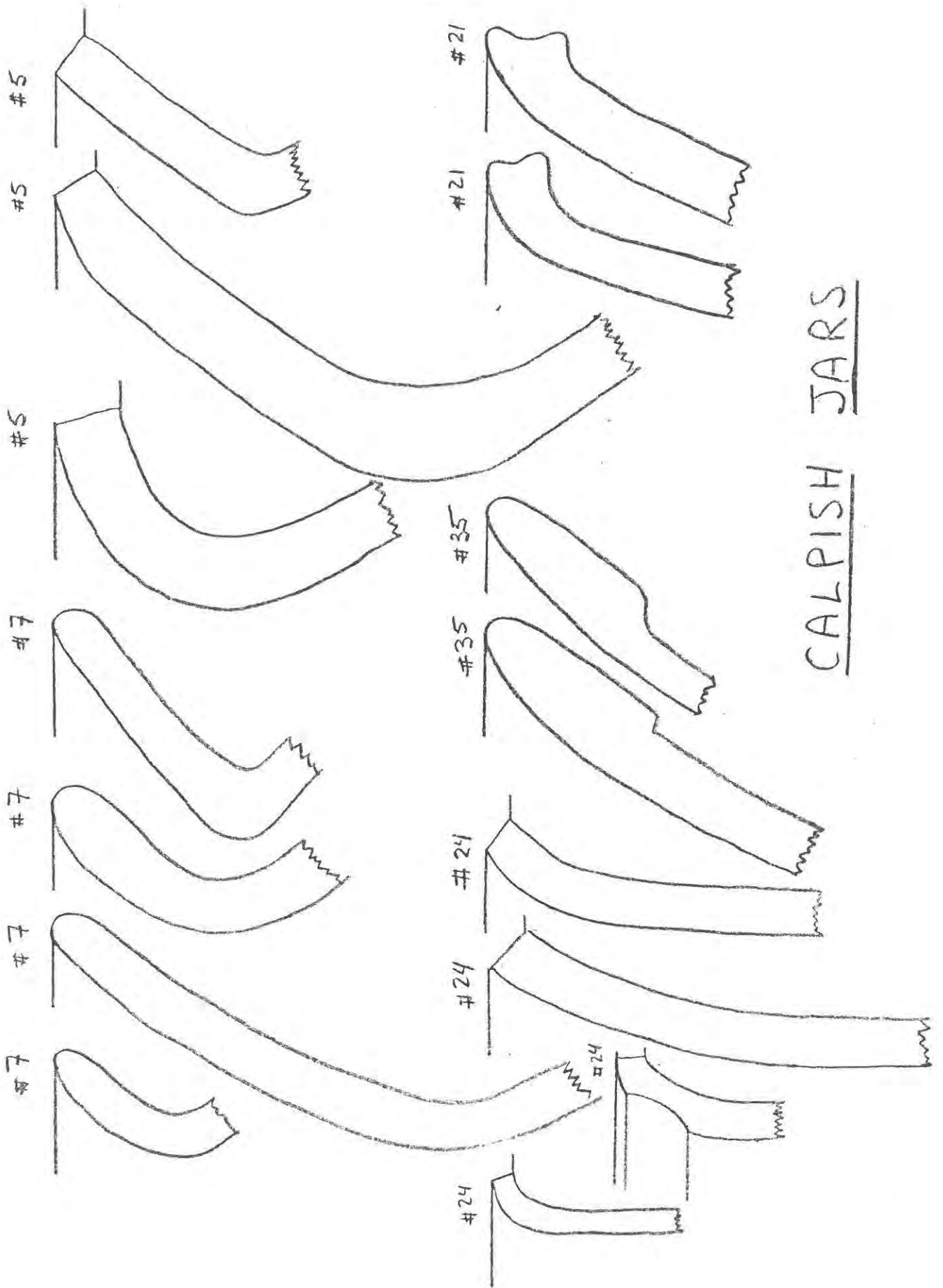

CALPISH JARS

Fig. 112

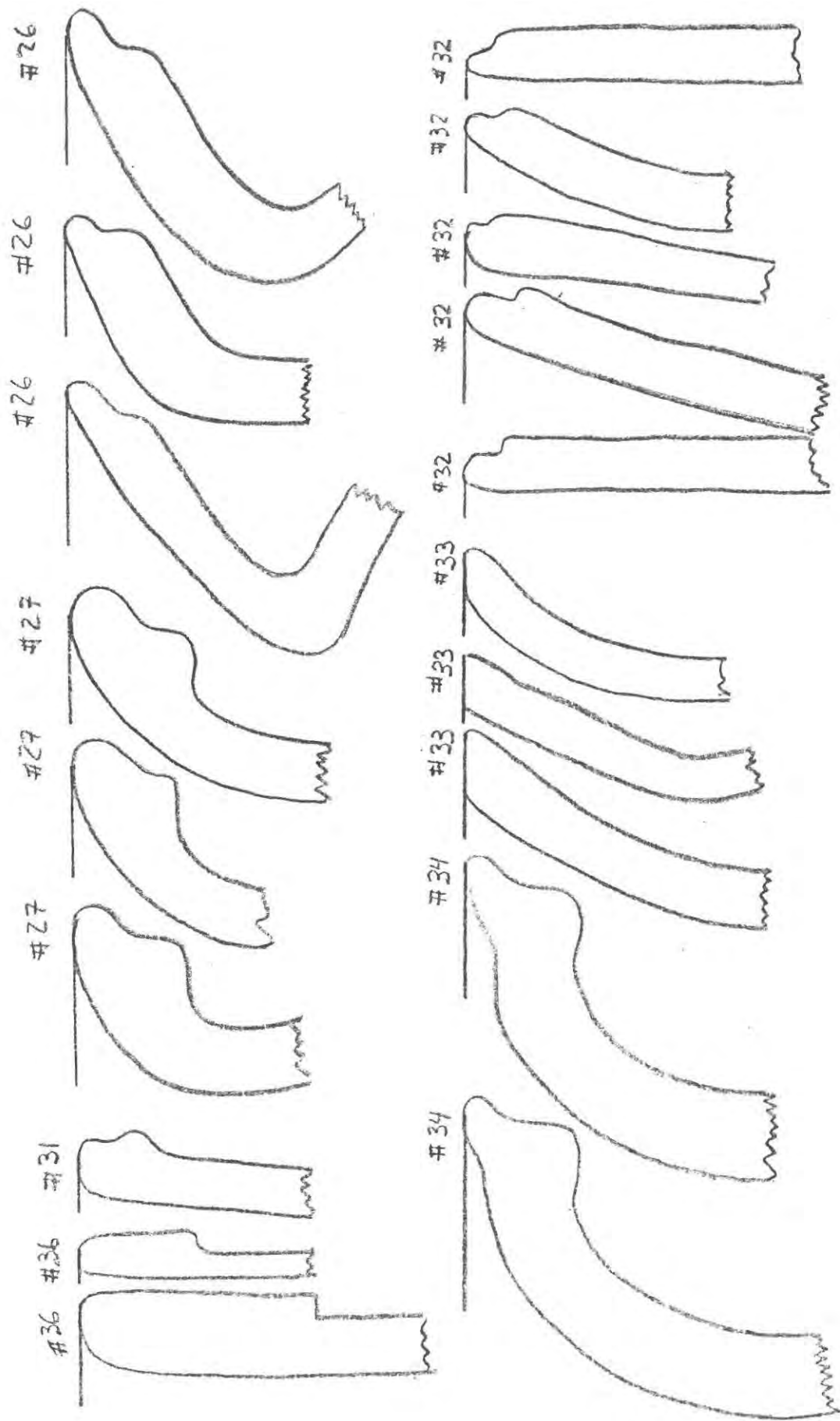

CALPISH JARS

Fig. 113

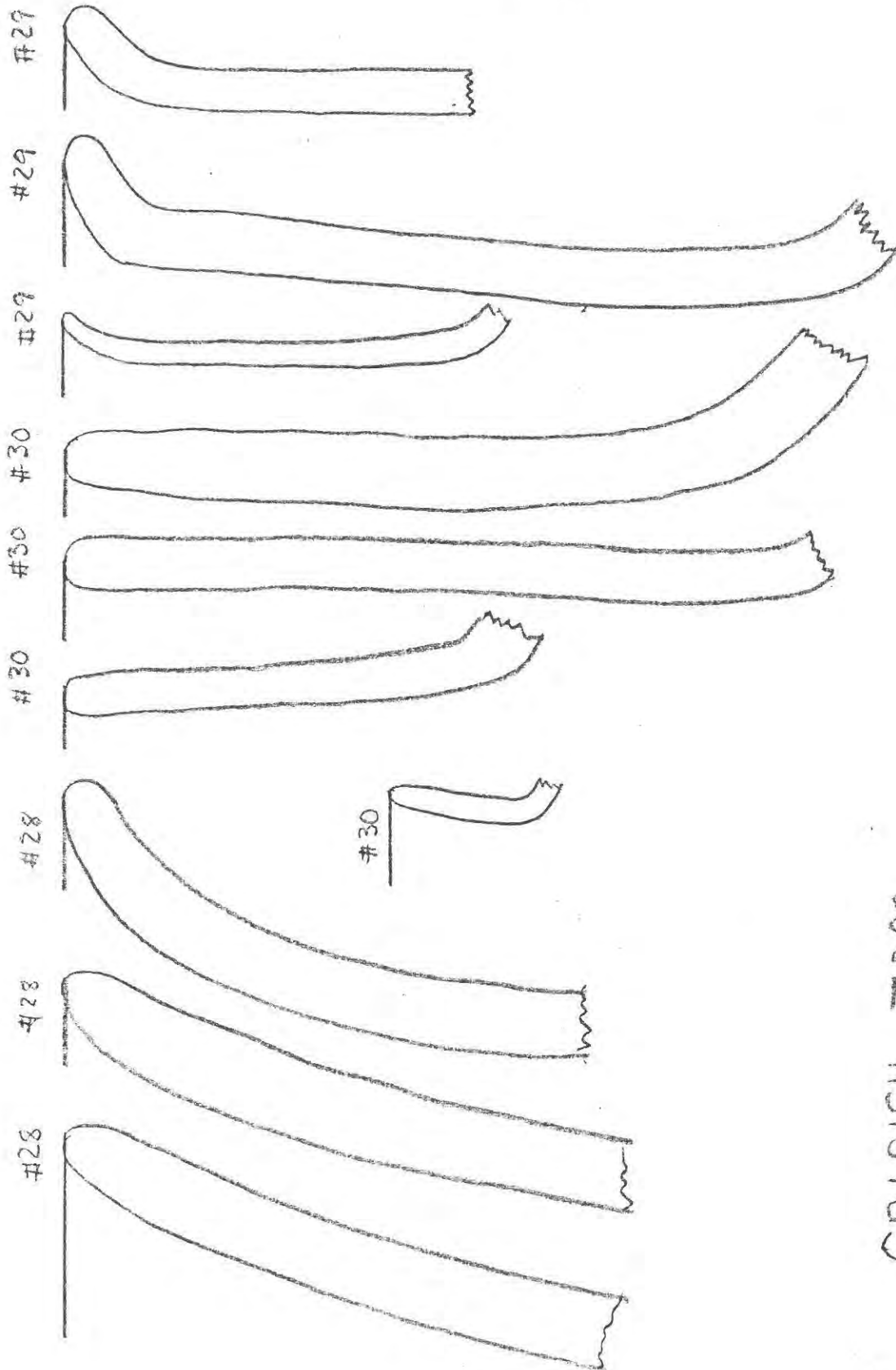

CALPISH JARS

Fig. 114

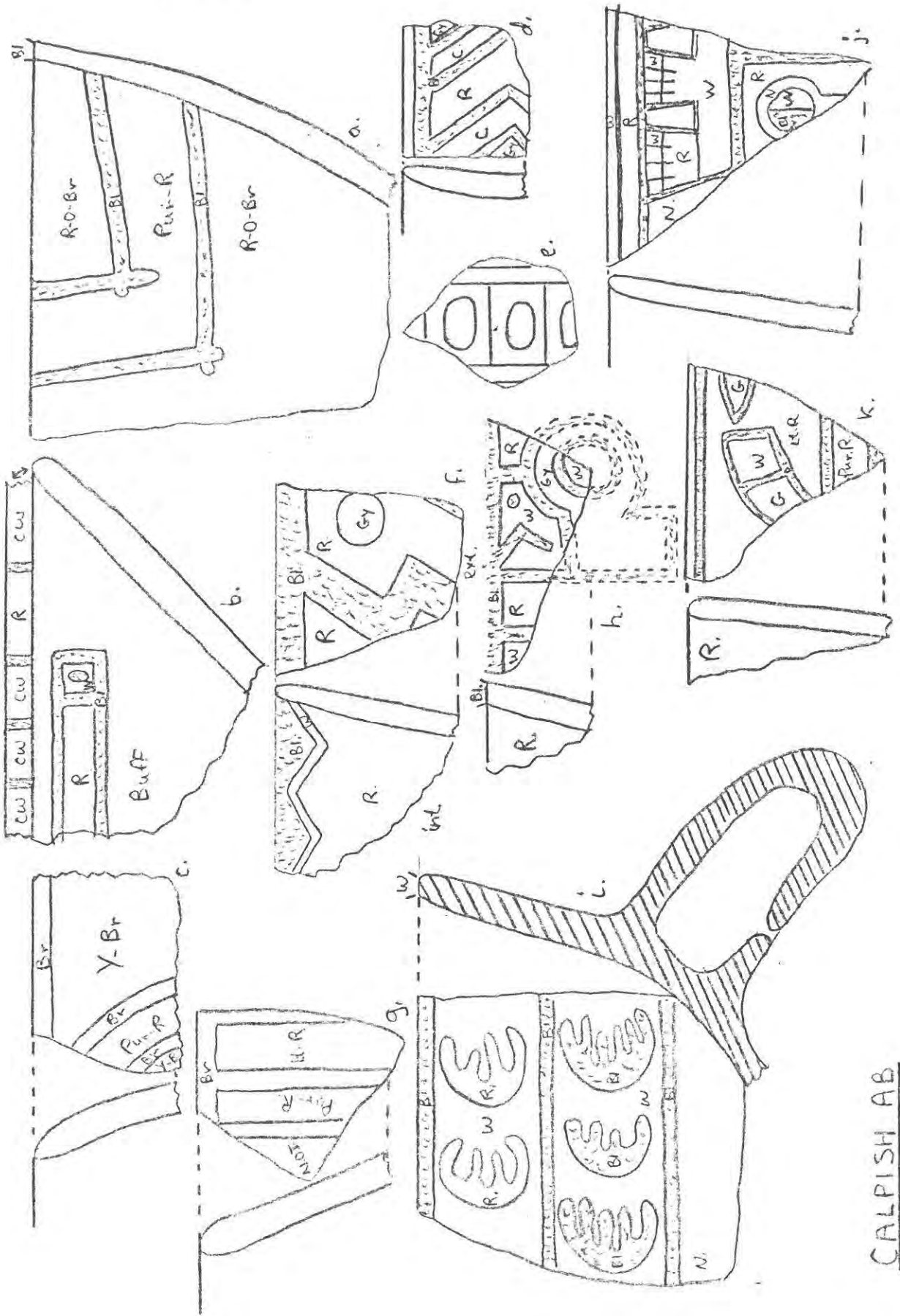

CALPISH AB

Fig. 115

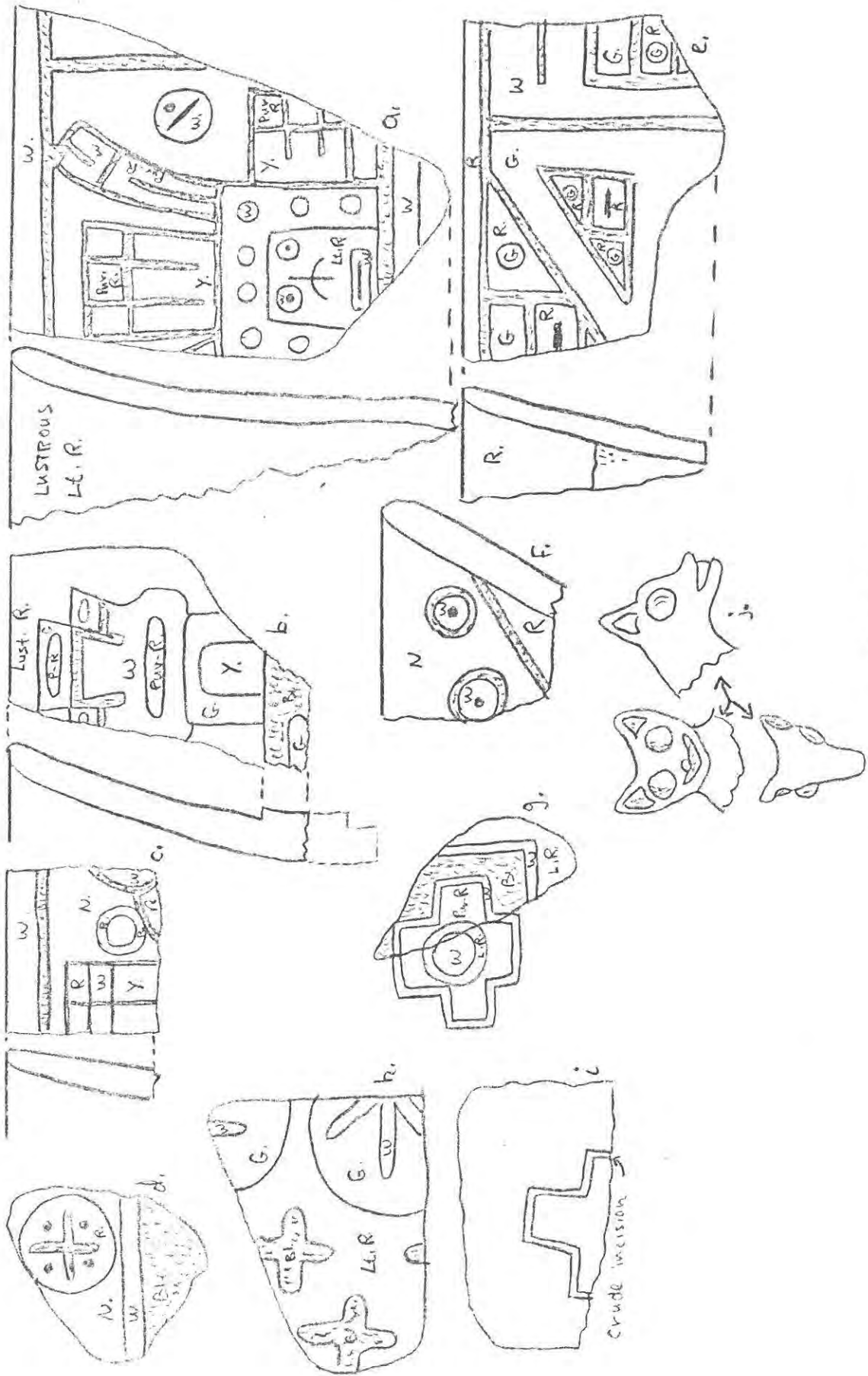

CALPISH AB

Fig. 116

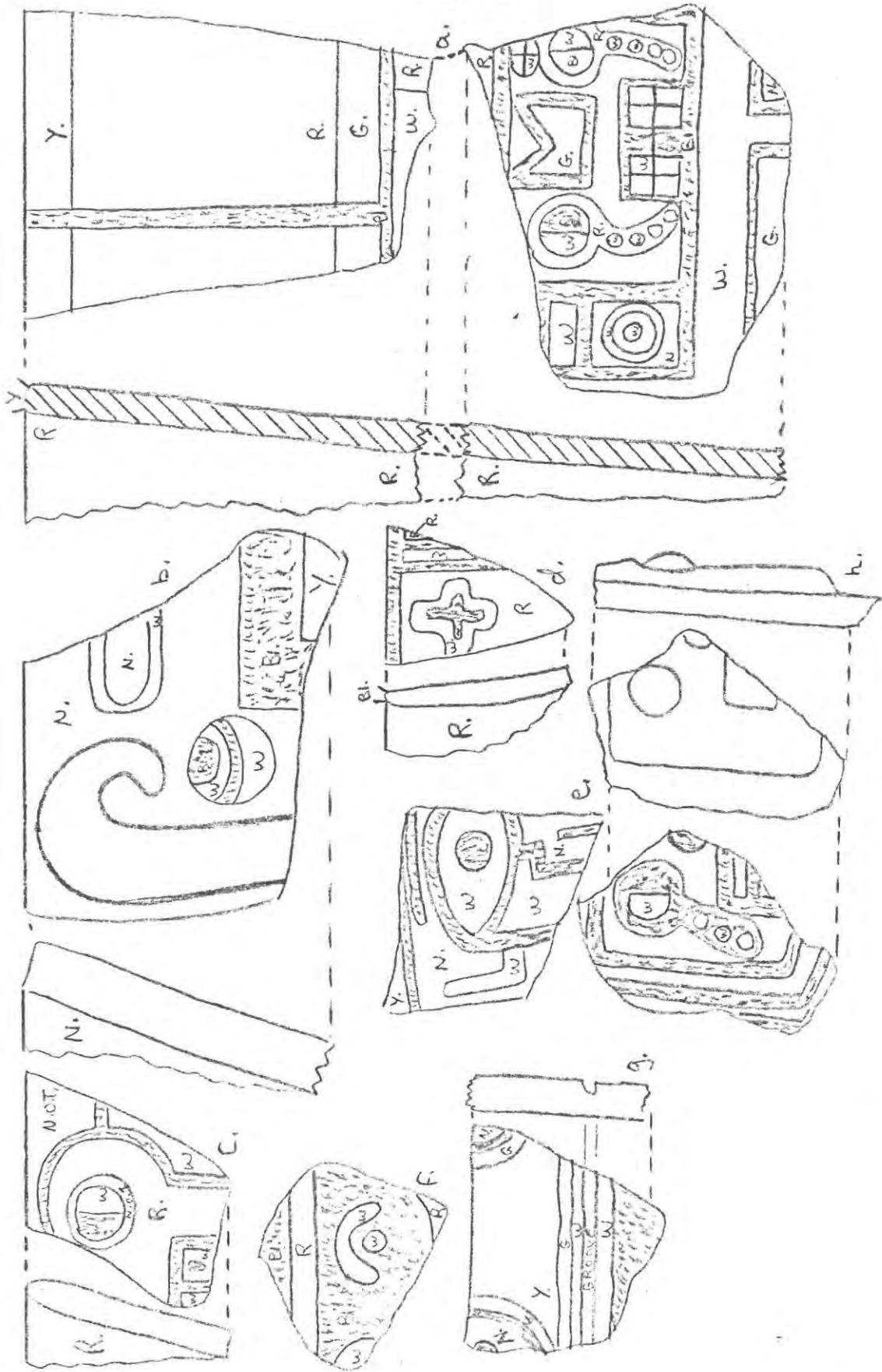

CALPISH B, BC

Fig. 117

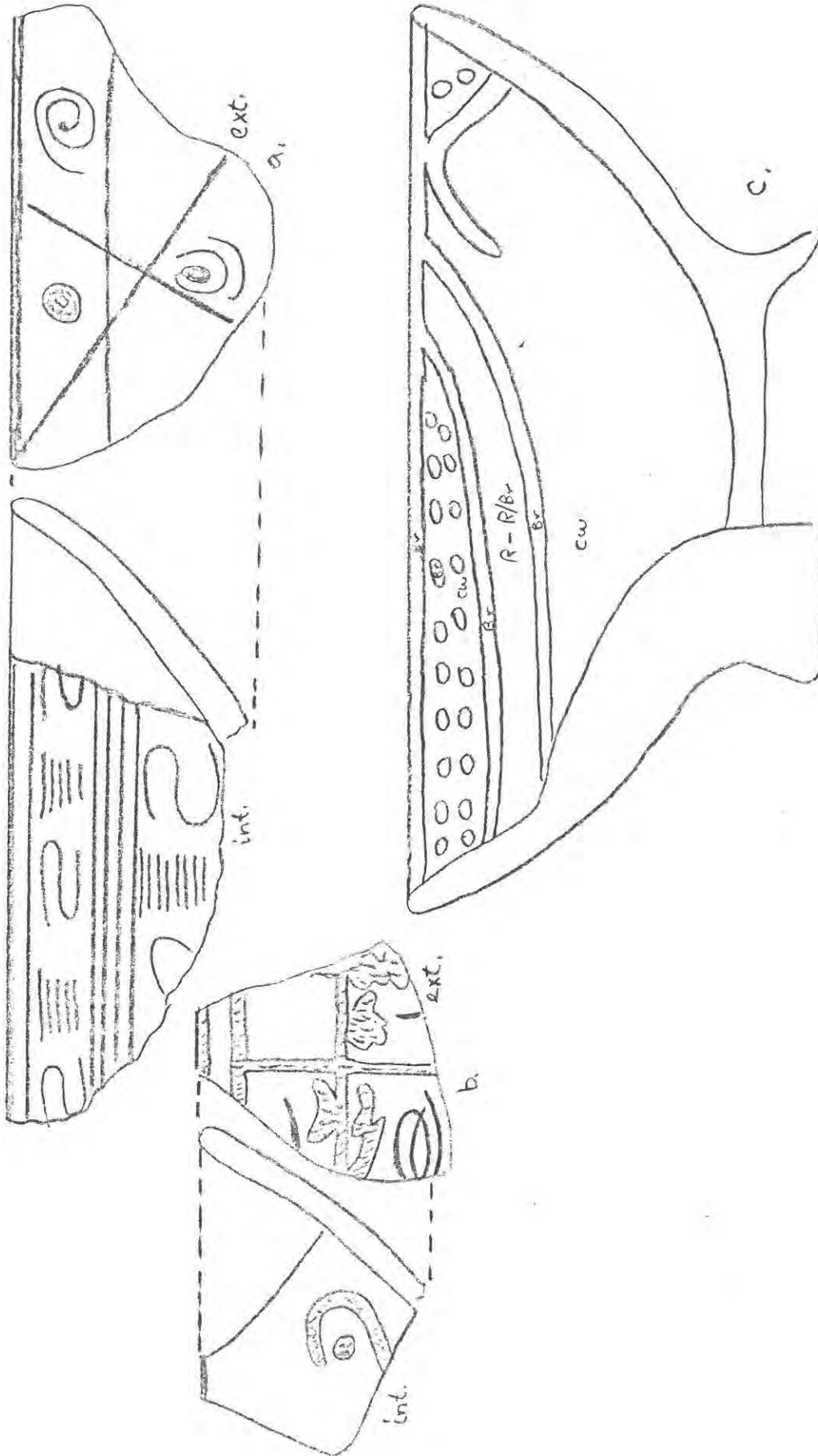

CALPISH AB

Fig. 118

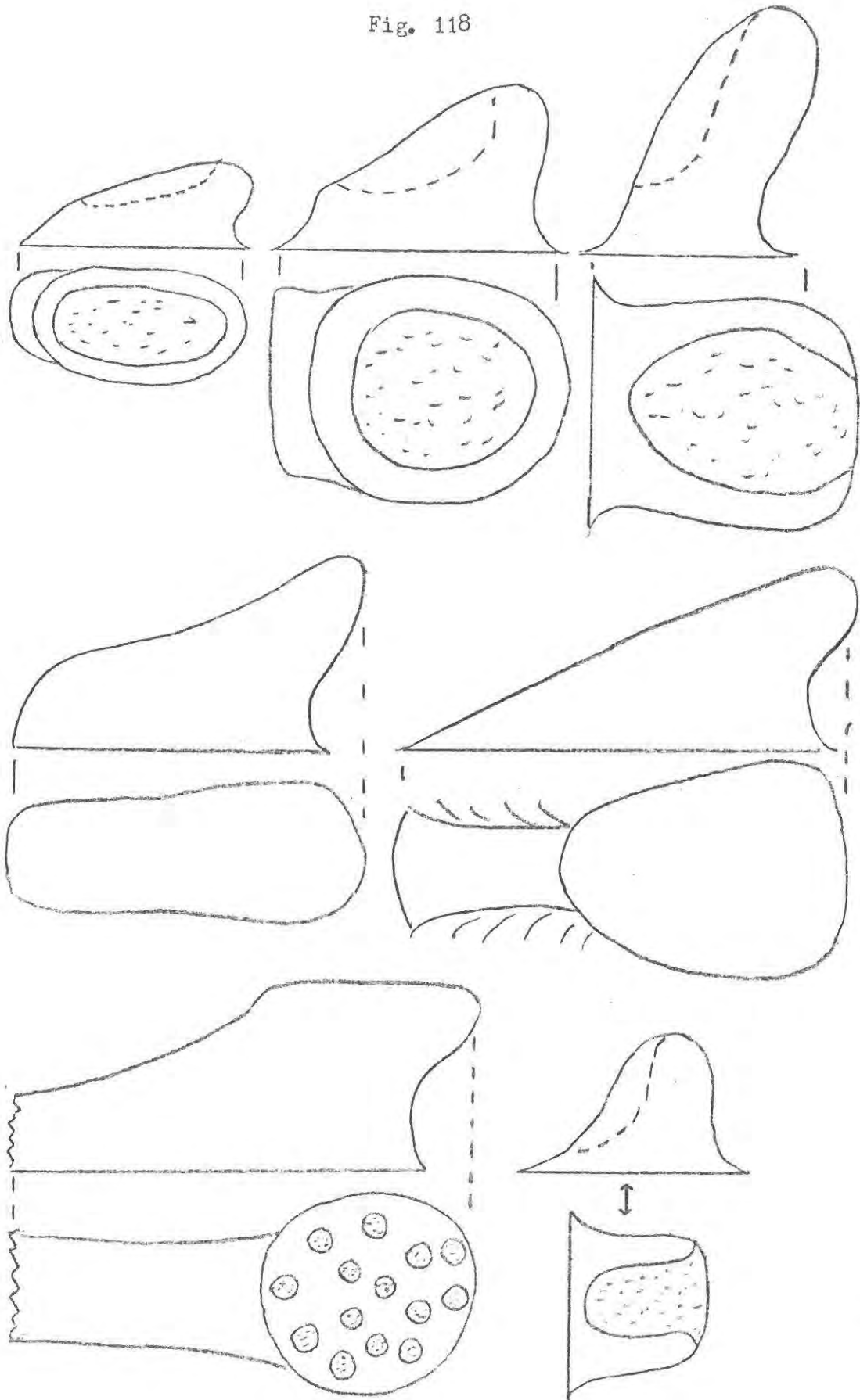

CALPISH A, AB JAR LUGS

Fig. 119

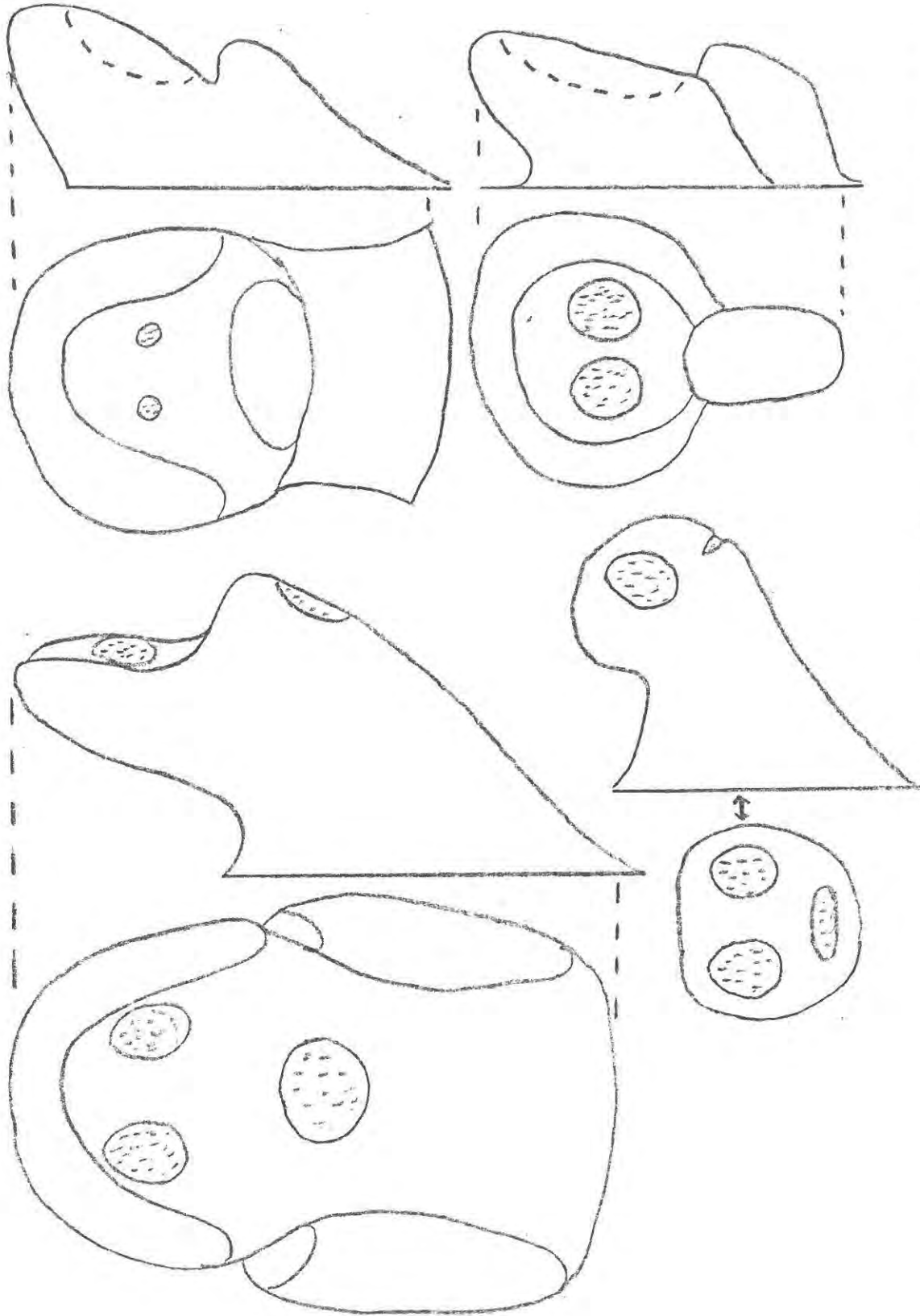

CALPISH B, C FACE JAR LUGS

Fig. 120

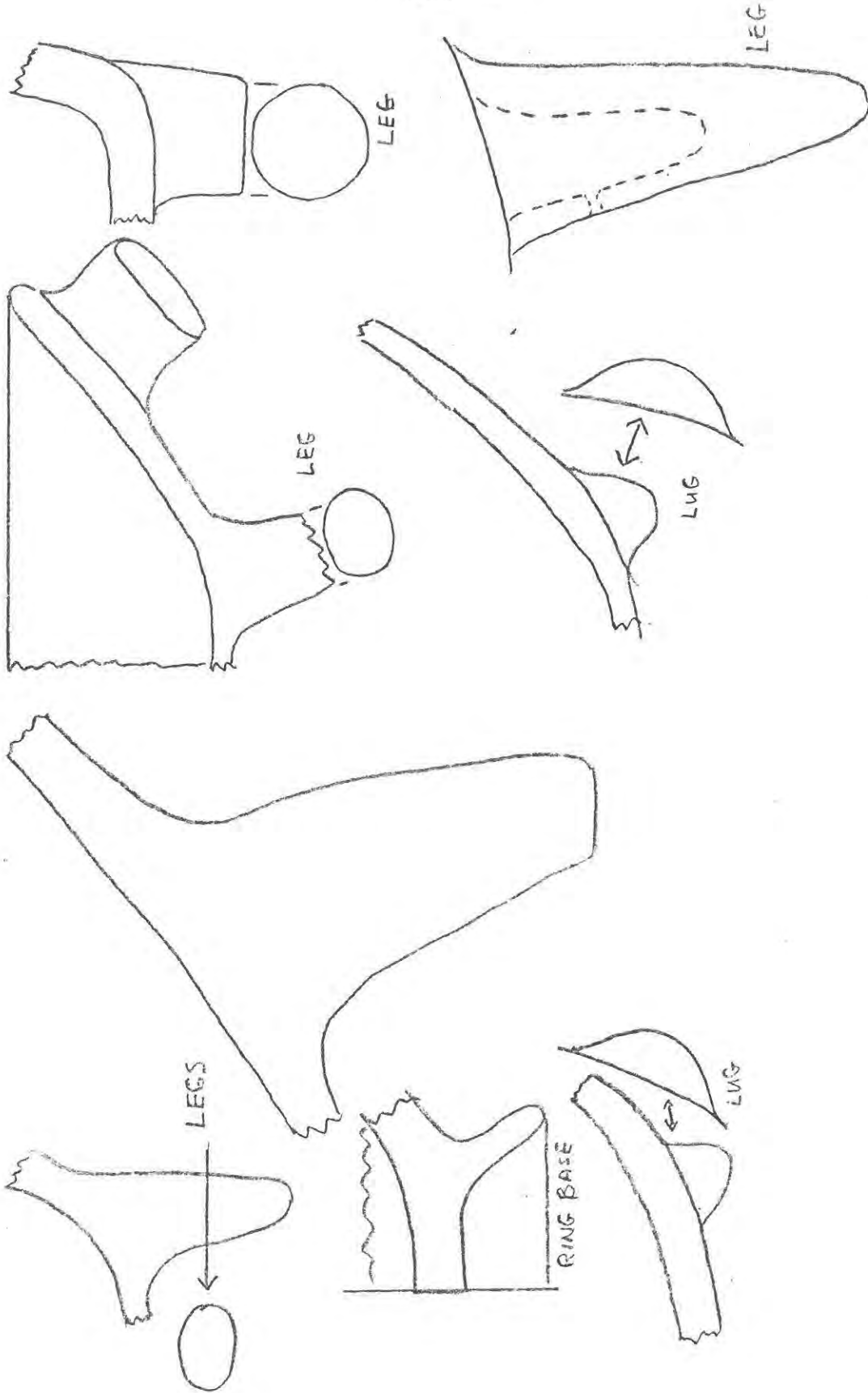

CALPISH A, AB LEGS, BASES

Fig. 121

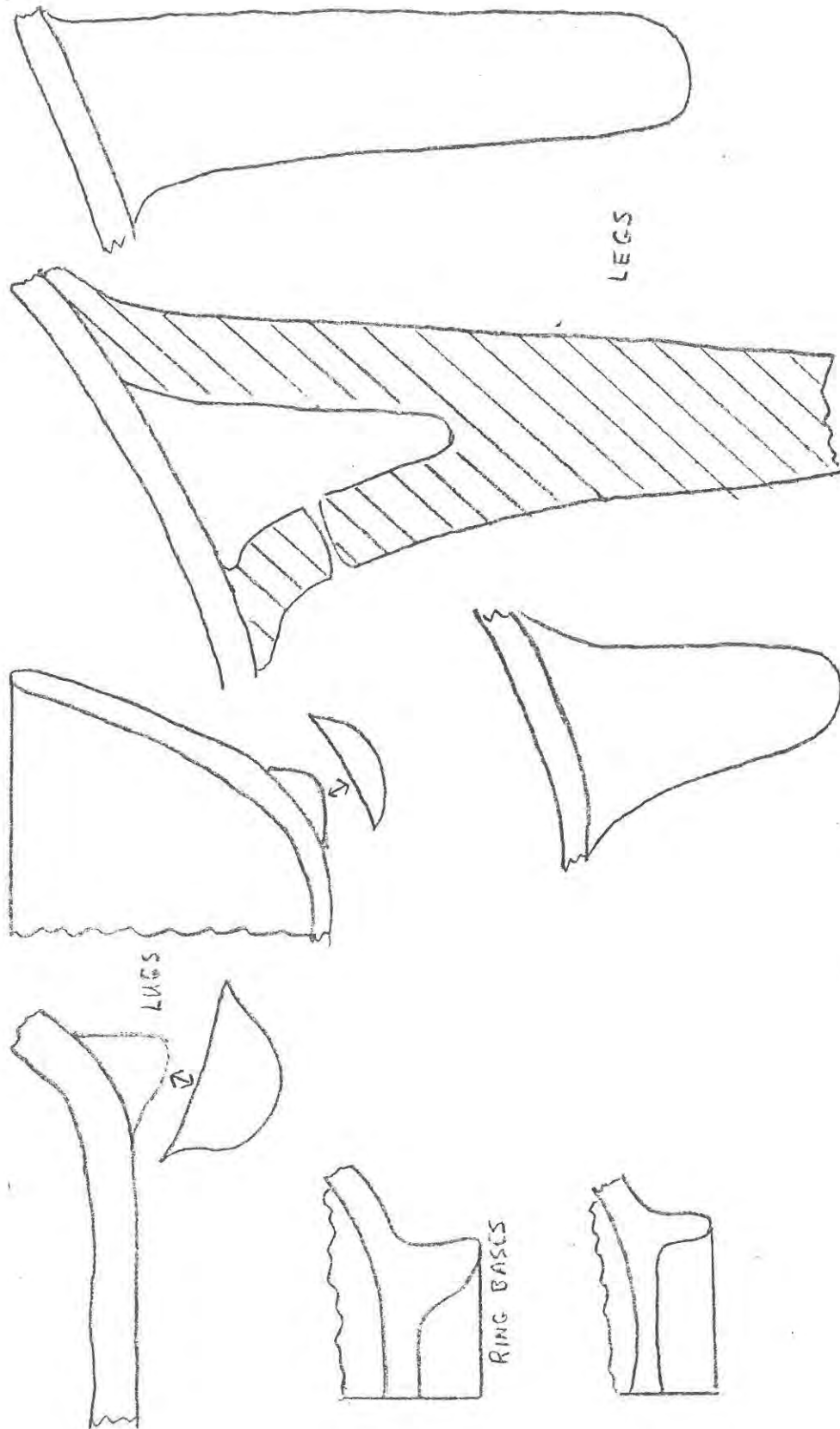

CALPISH B. C. SUPPORTS

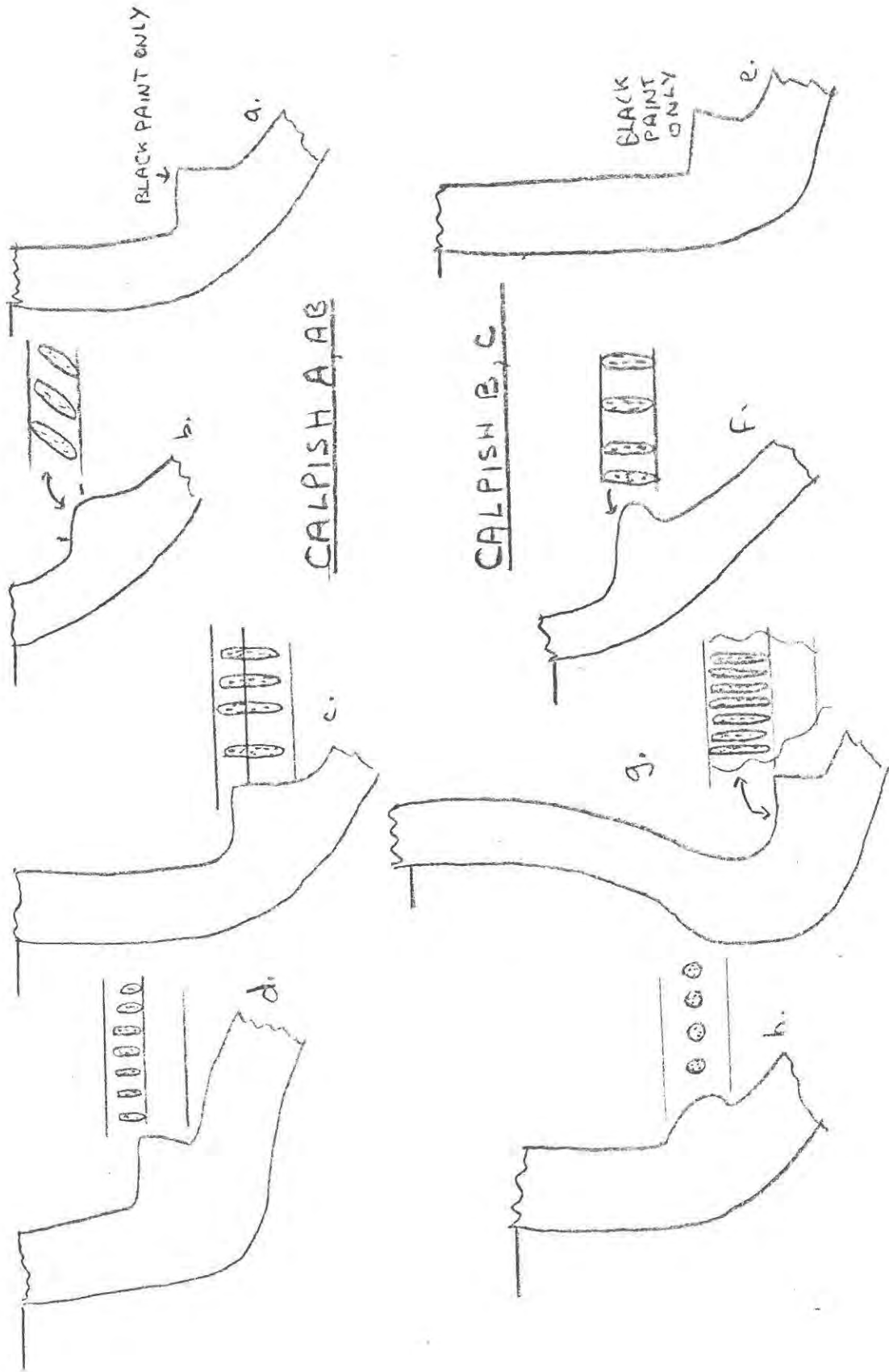

CALPISH JAR NECK APPLIQUES

Fig. 123

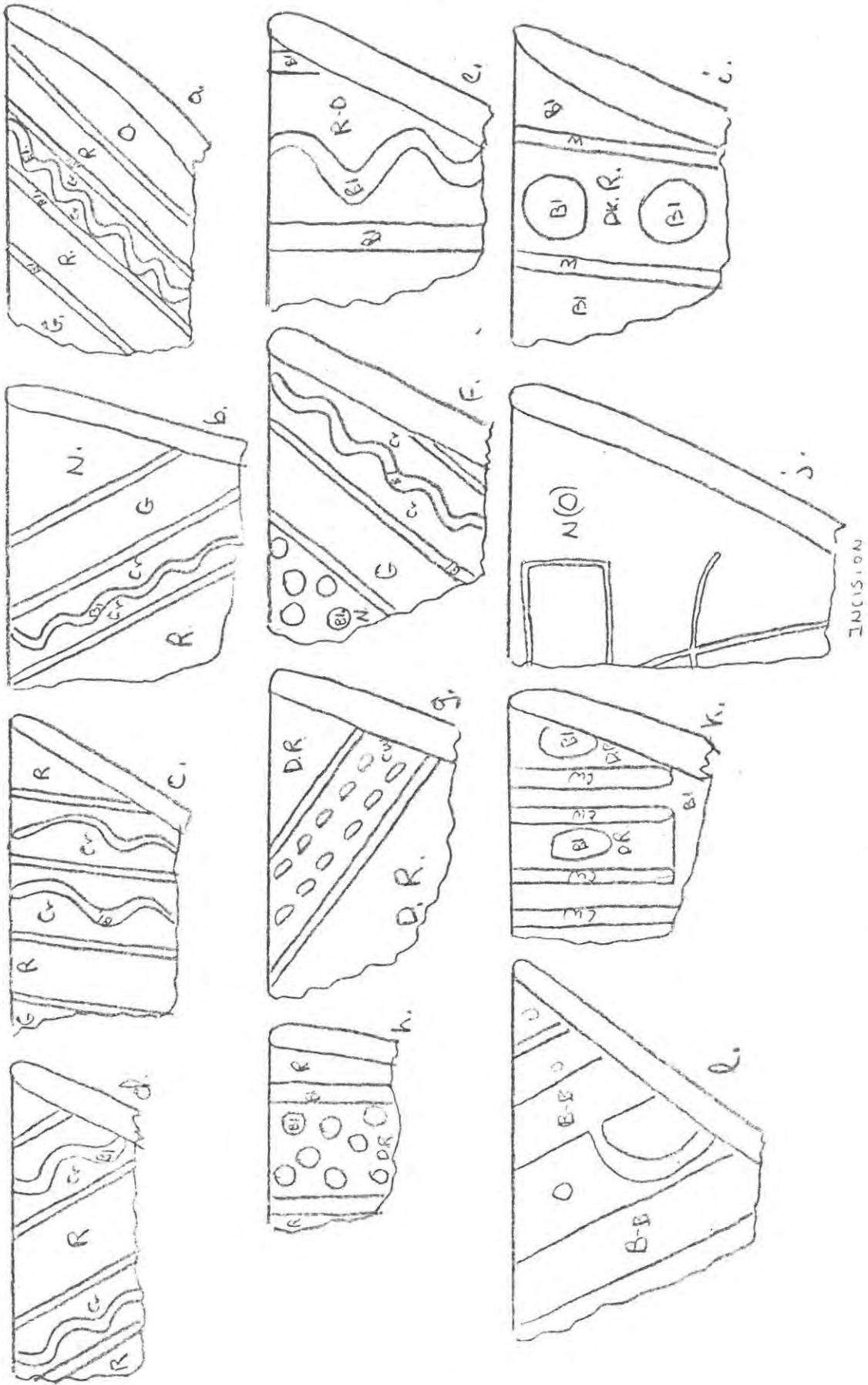

CALPISH A

Fig. 124

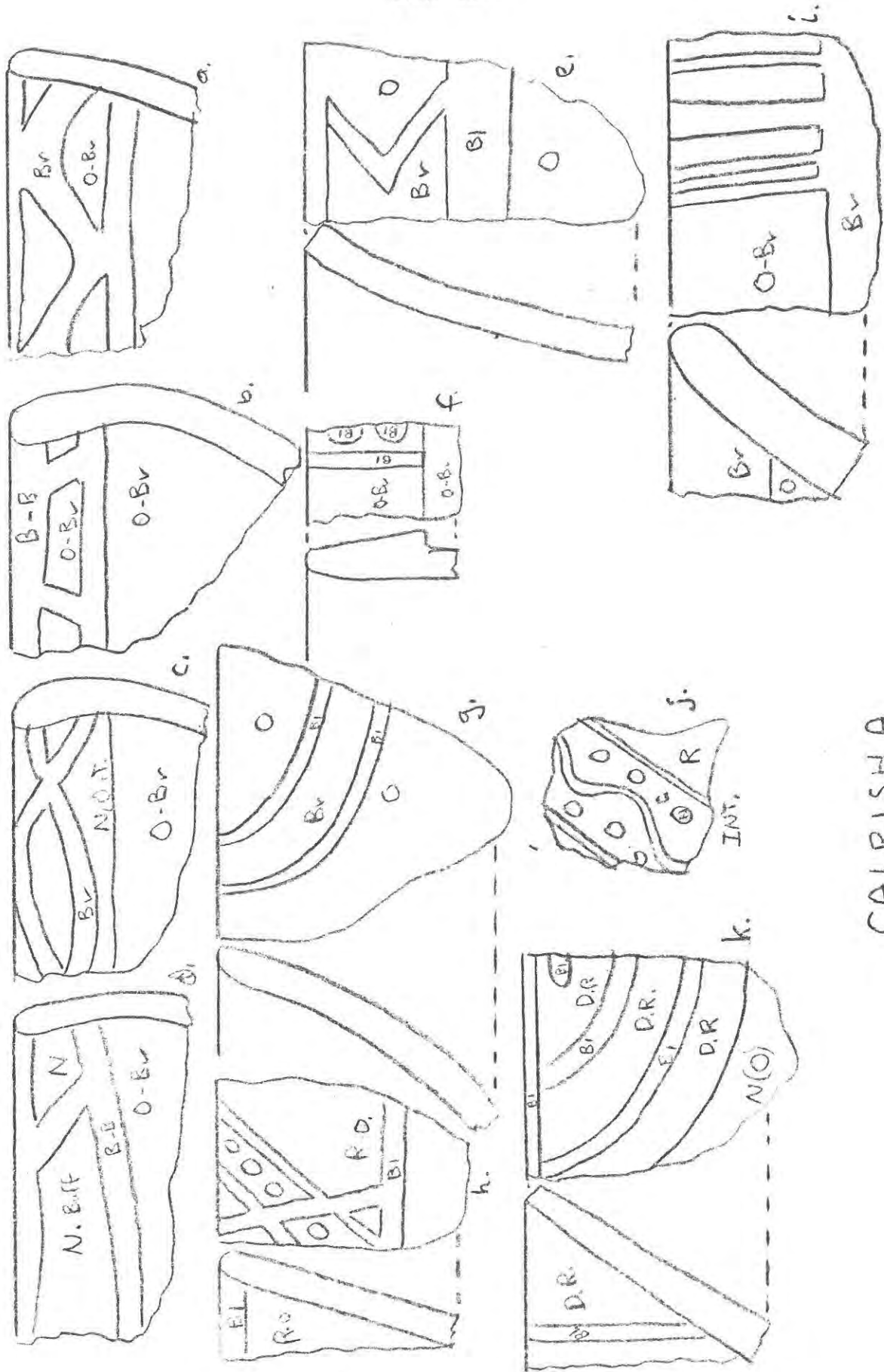

CALPISHA

Fig. 126

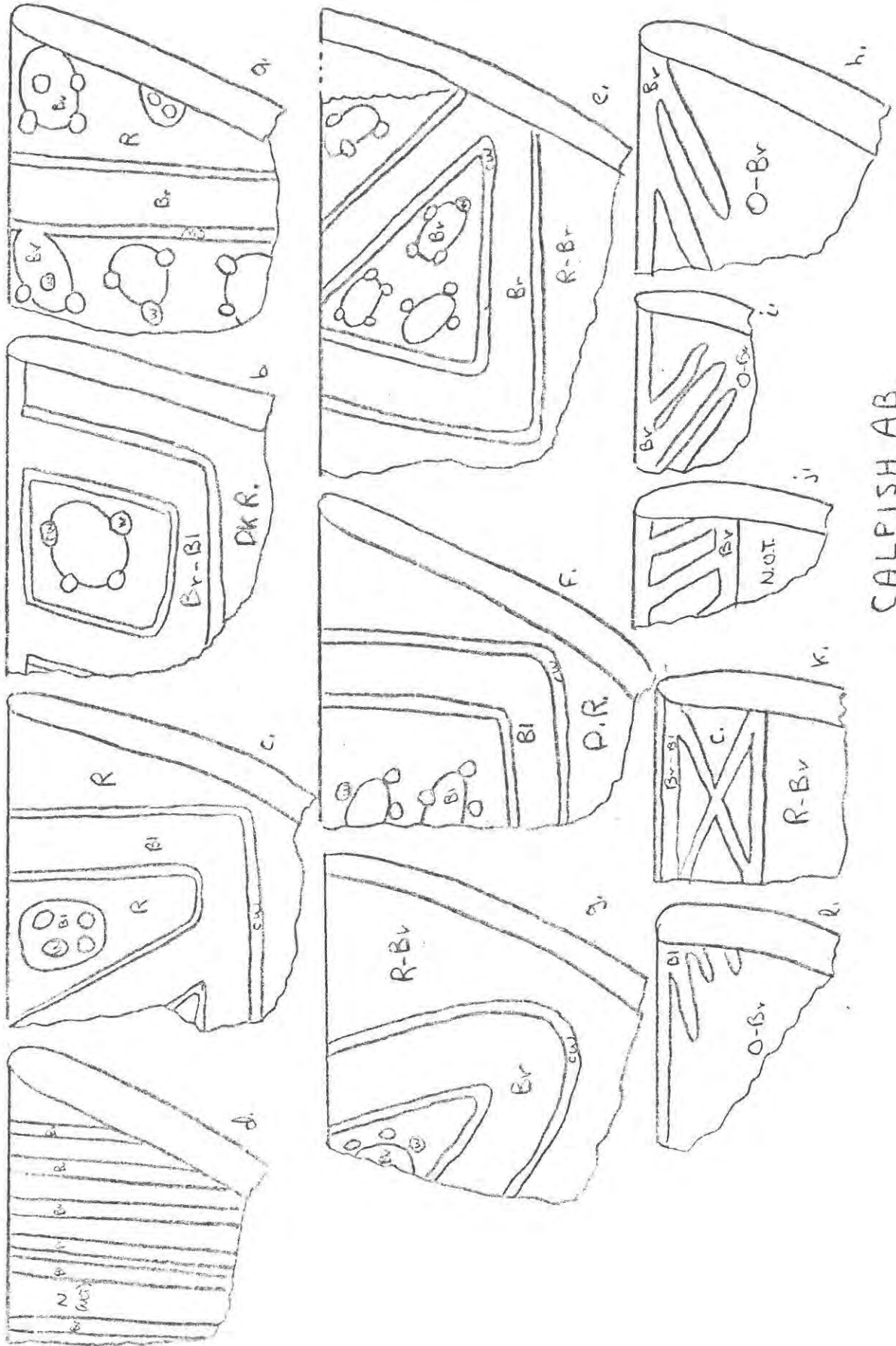

CALPISH AB

Fig. 127

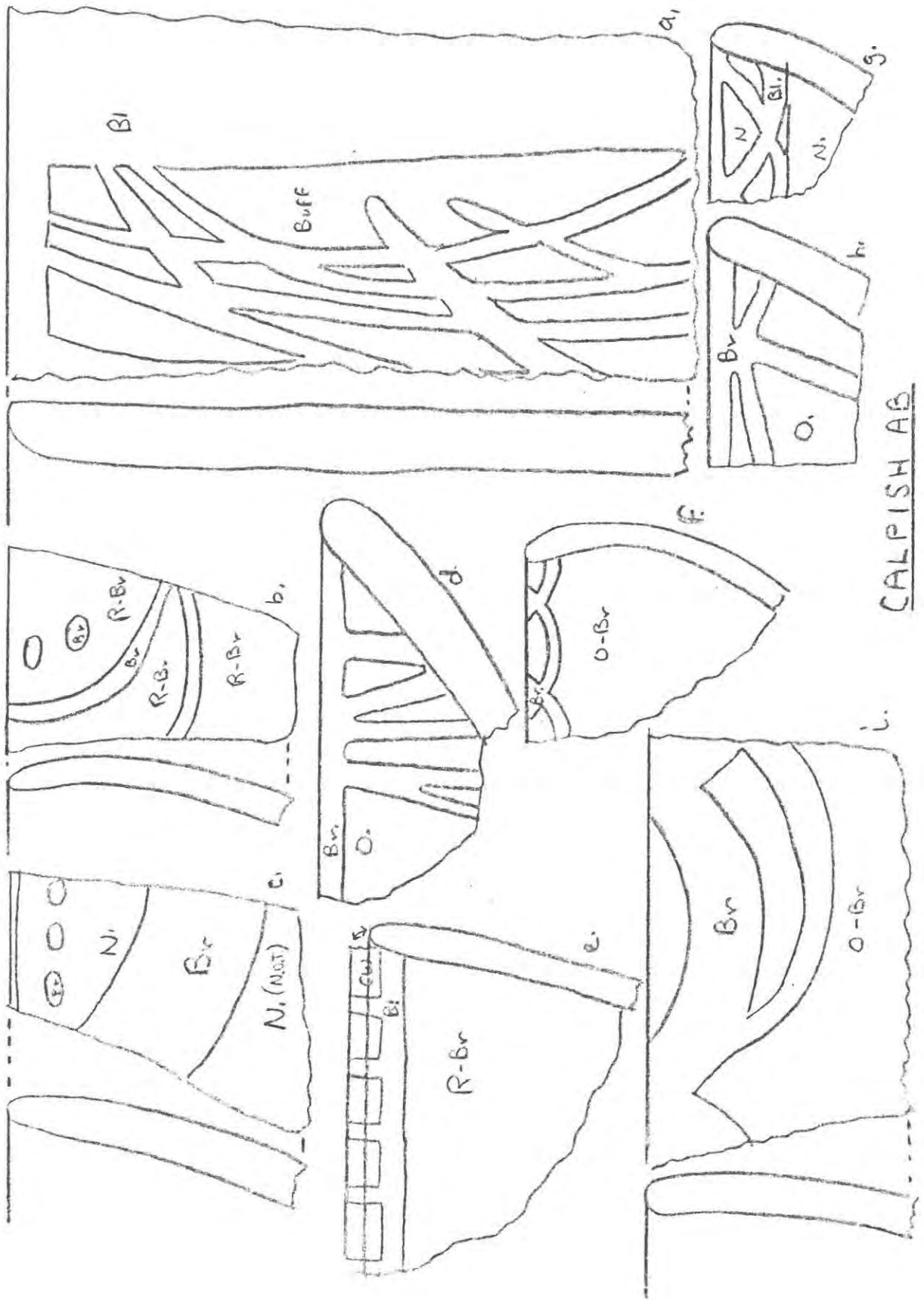
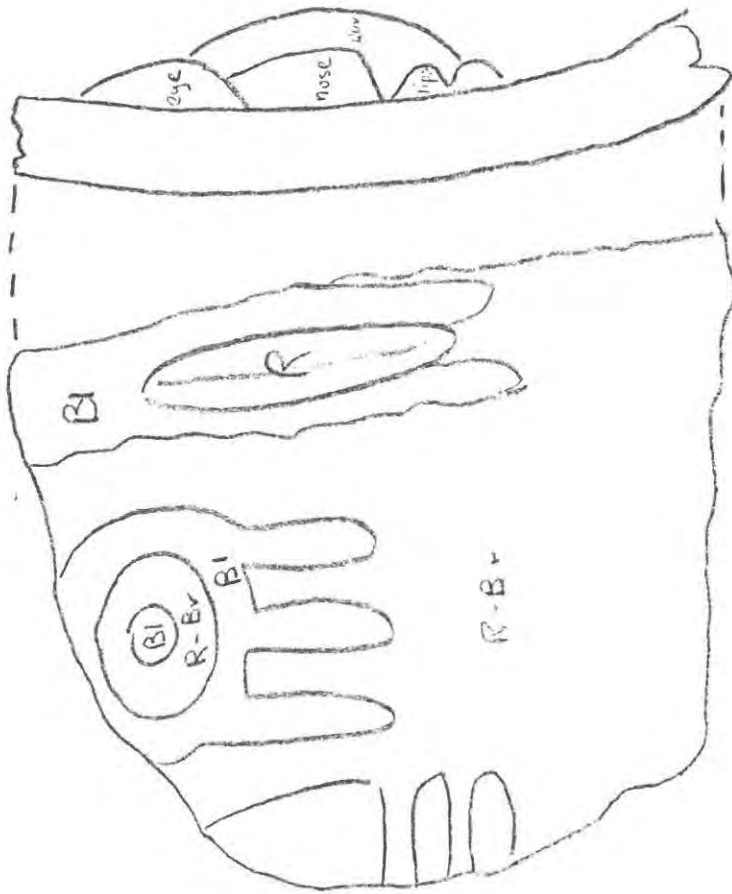
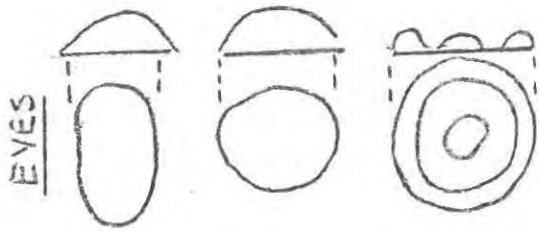
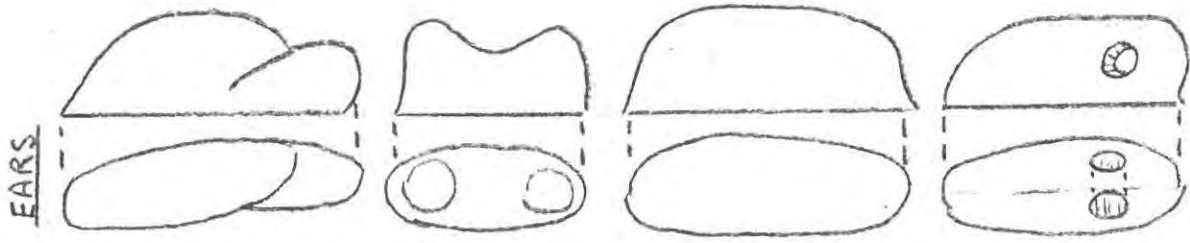

Fig. 128



MODELED CALPISH FACE FEATURES

Fig. 129

CALPISH AB - WARIWILLKA

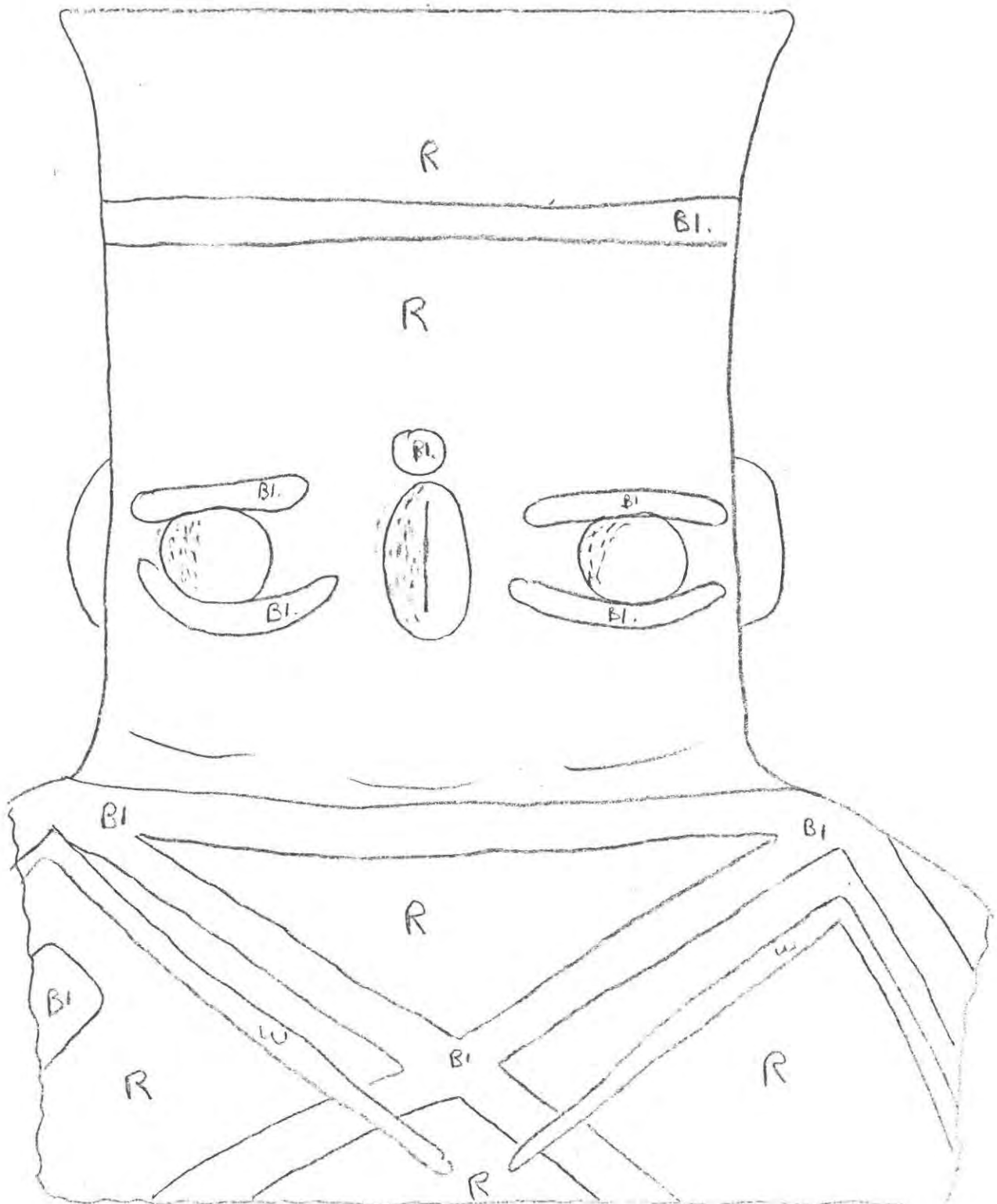
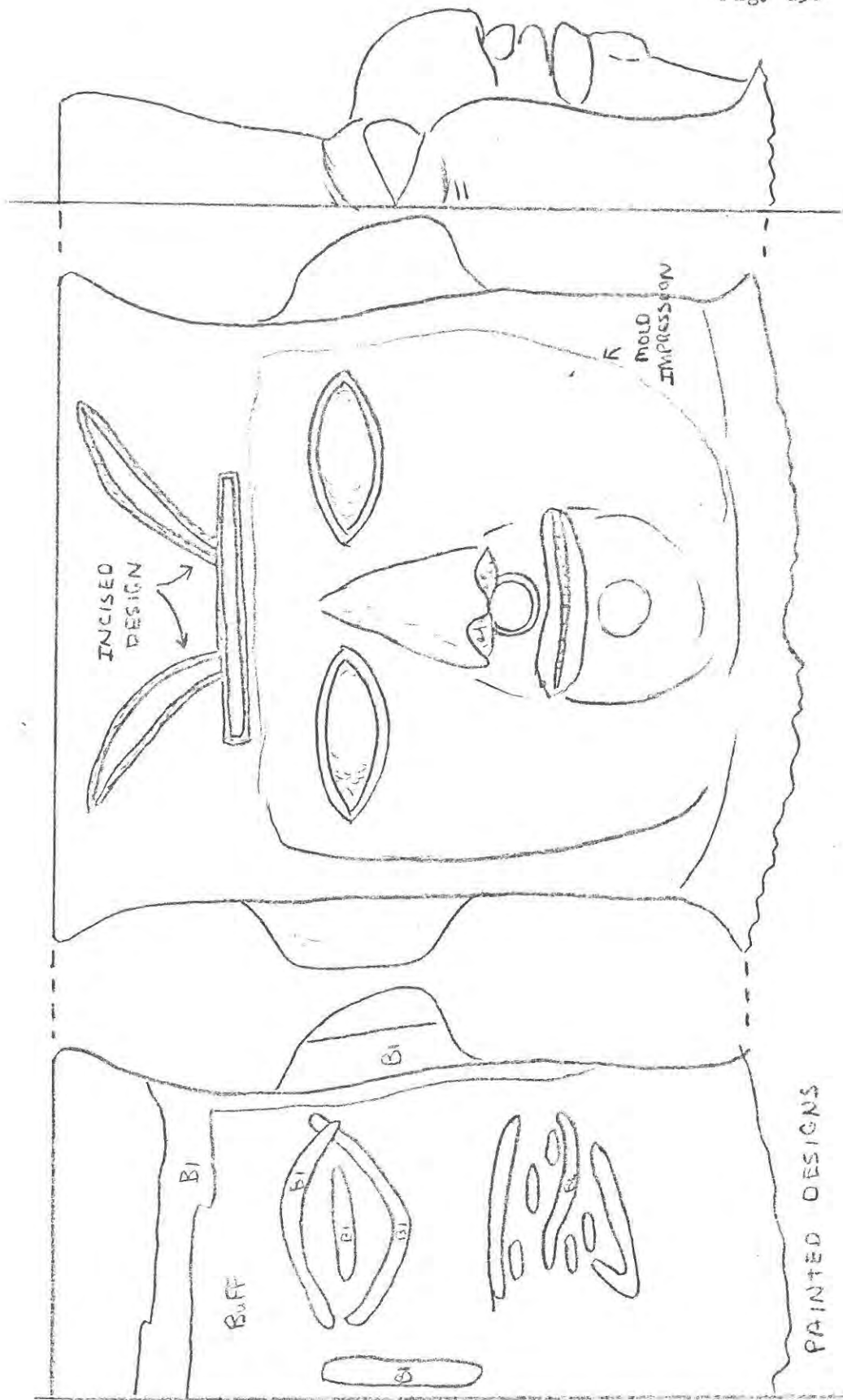

Fig. 130



CALPISH AB B - WARIWILKA

Fig. 131

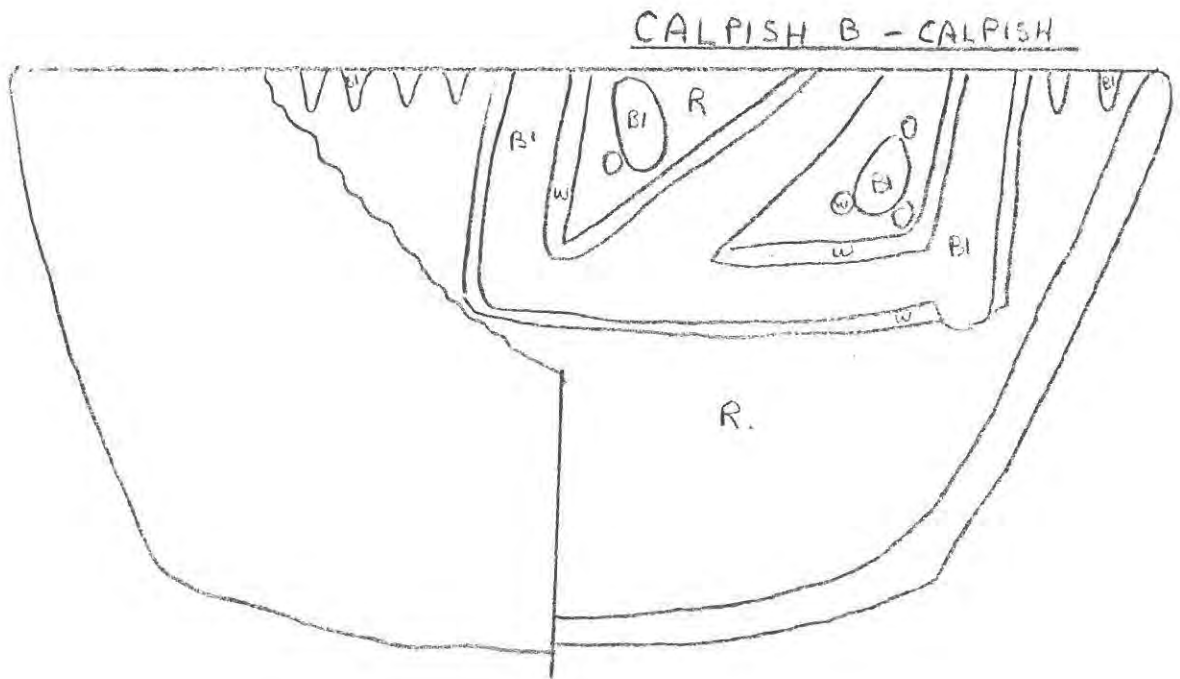
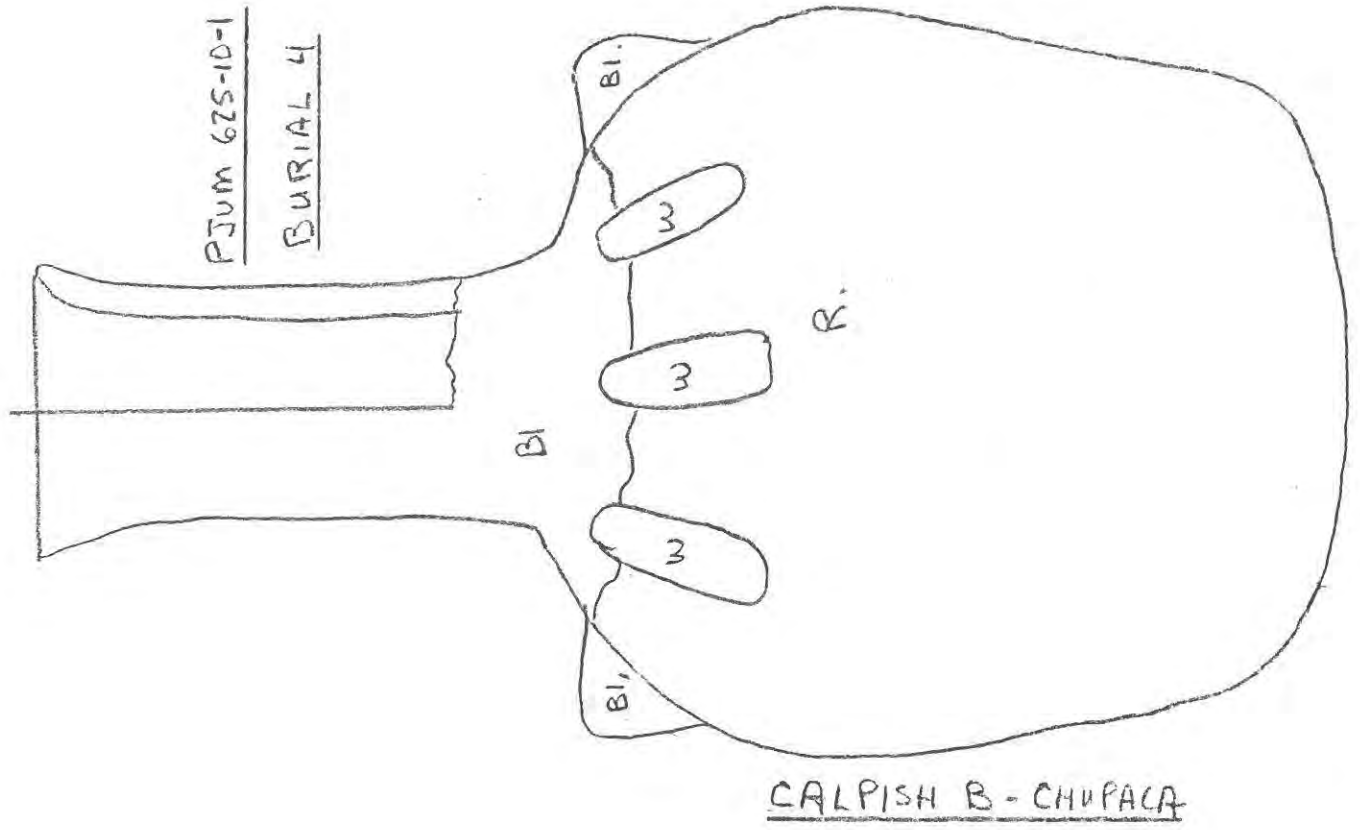
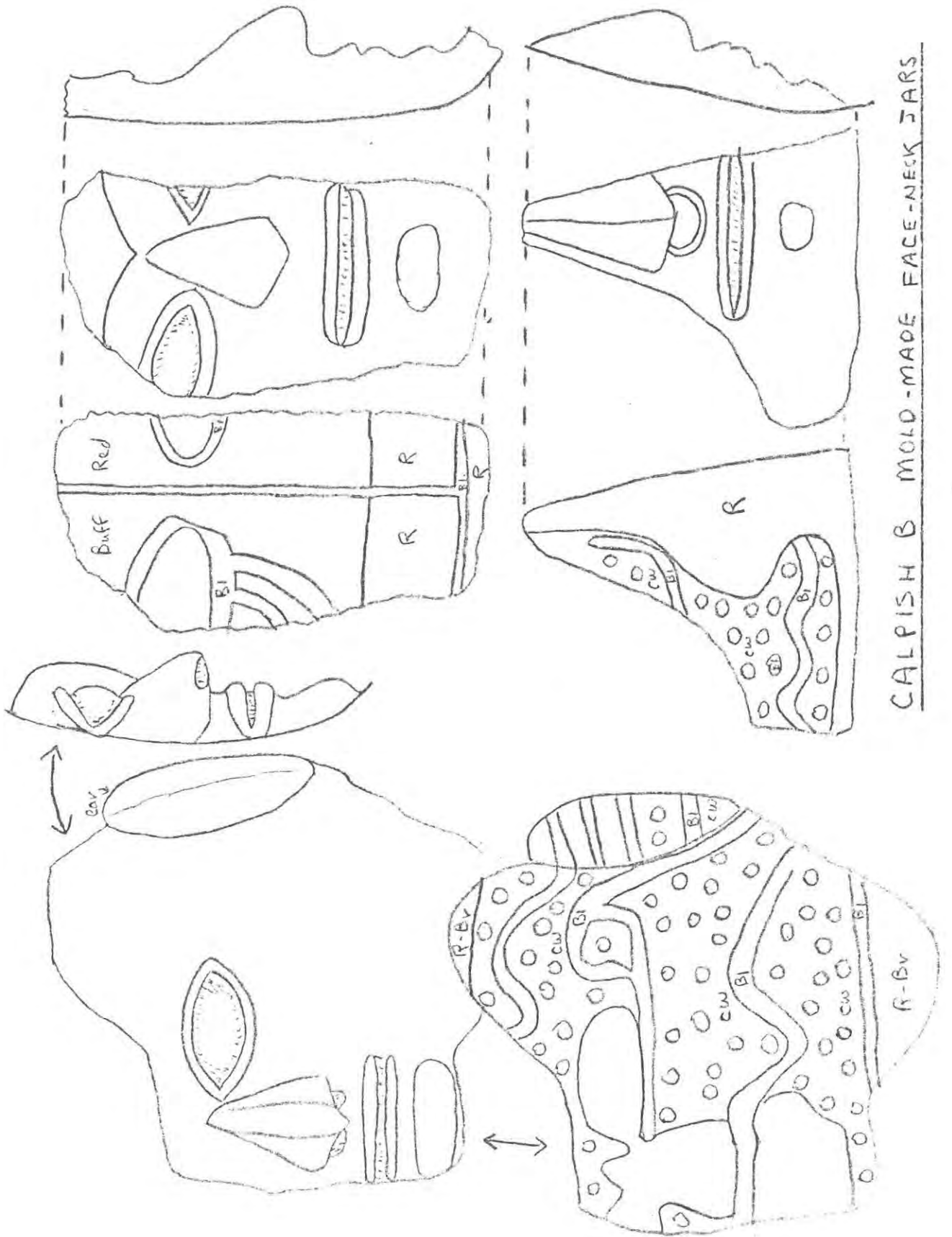

Fig. 132



CALPISH B MOLD-MADE FACE-NECK EARS

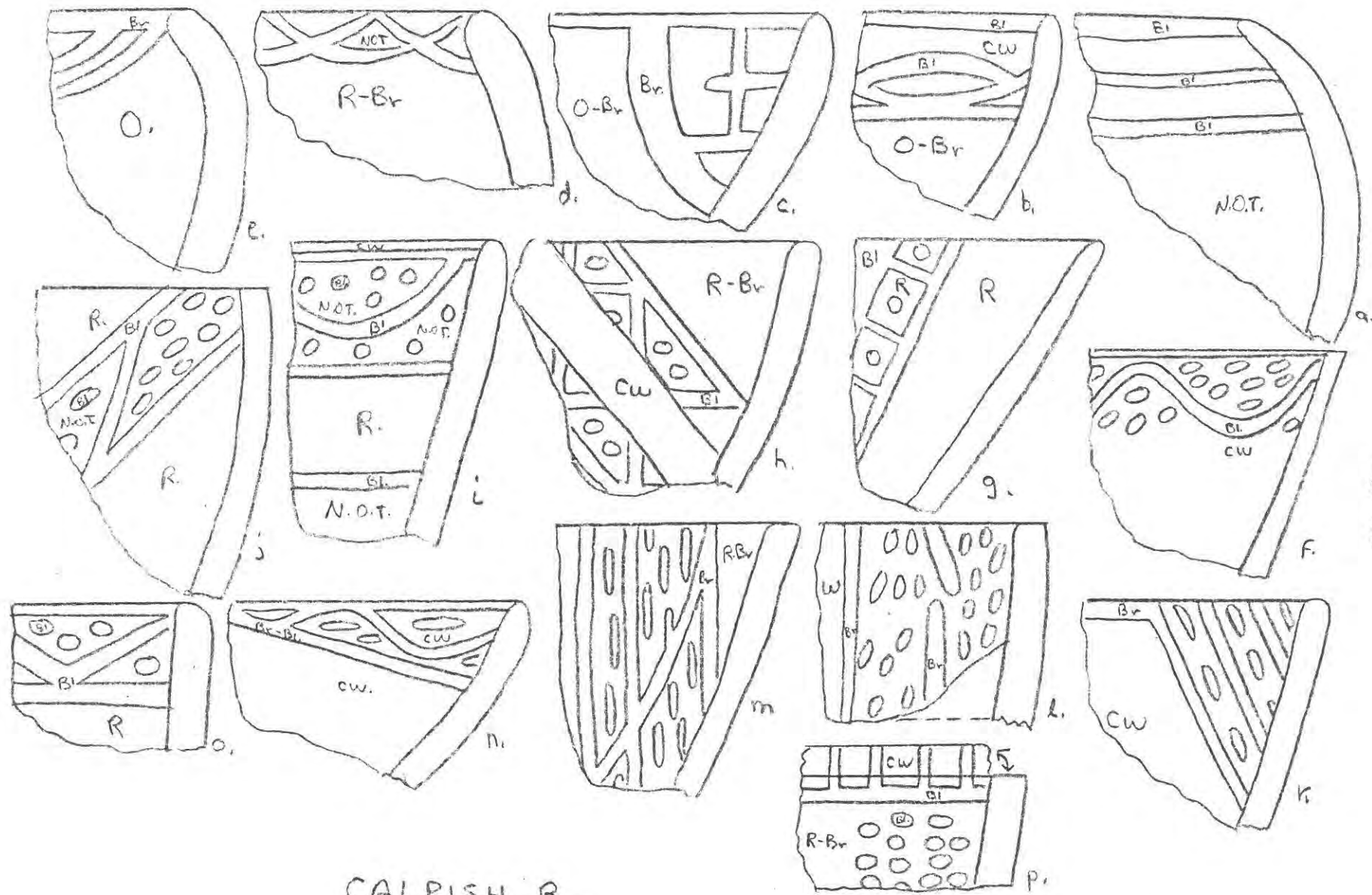
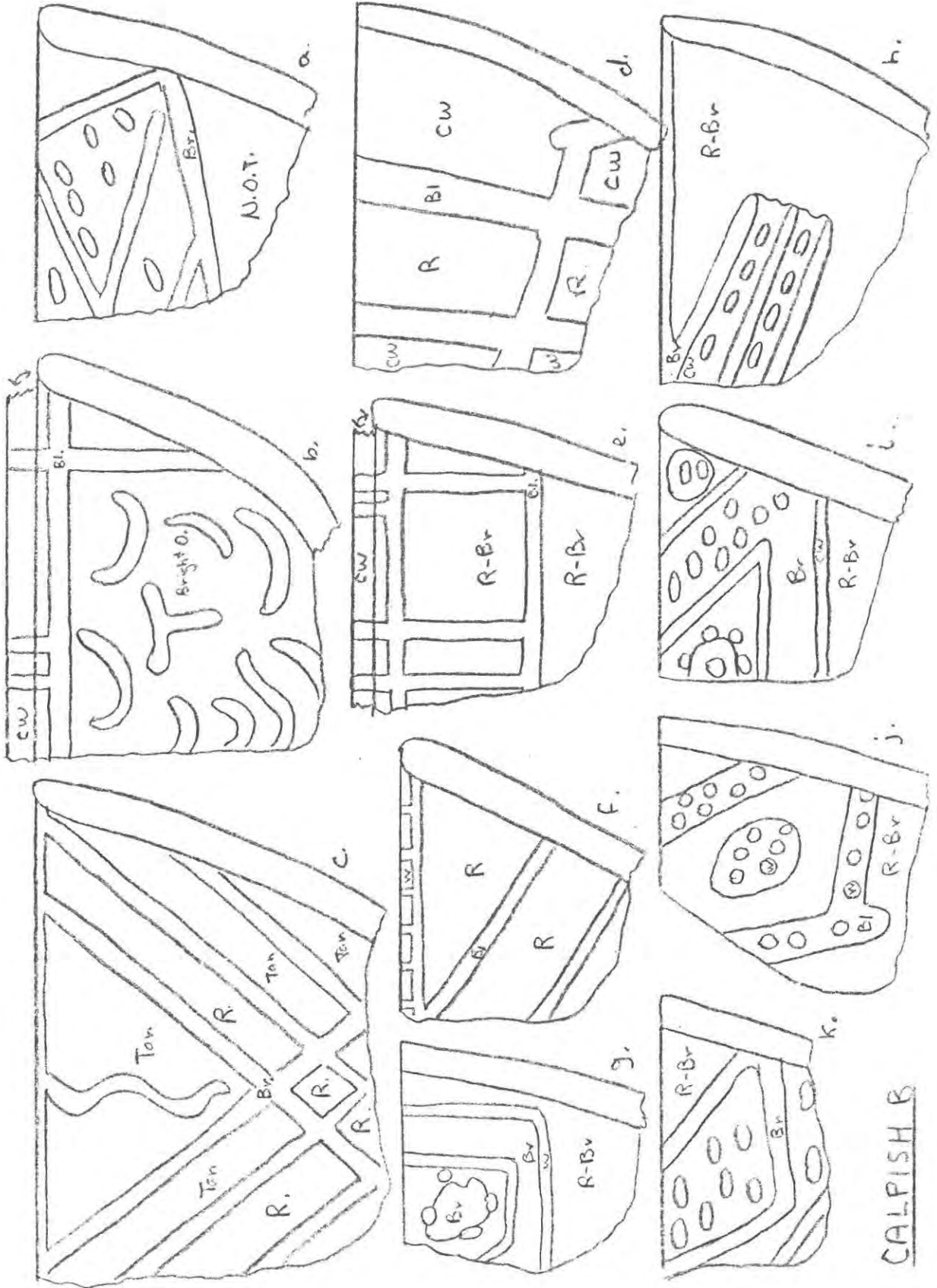

FIG. 133

CALPISH B.

Fig. 134



CALPISH B

Fig. 135

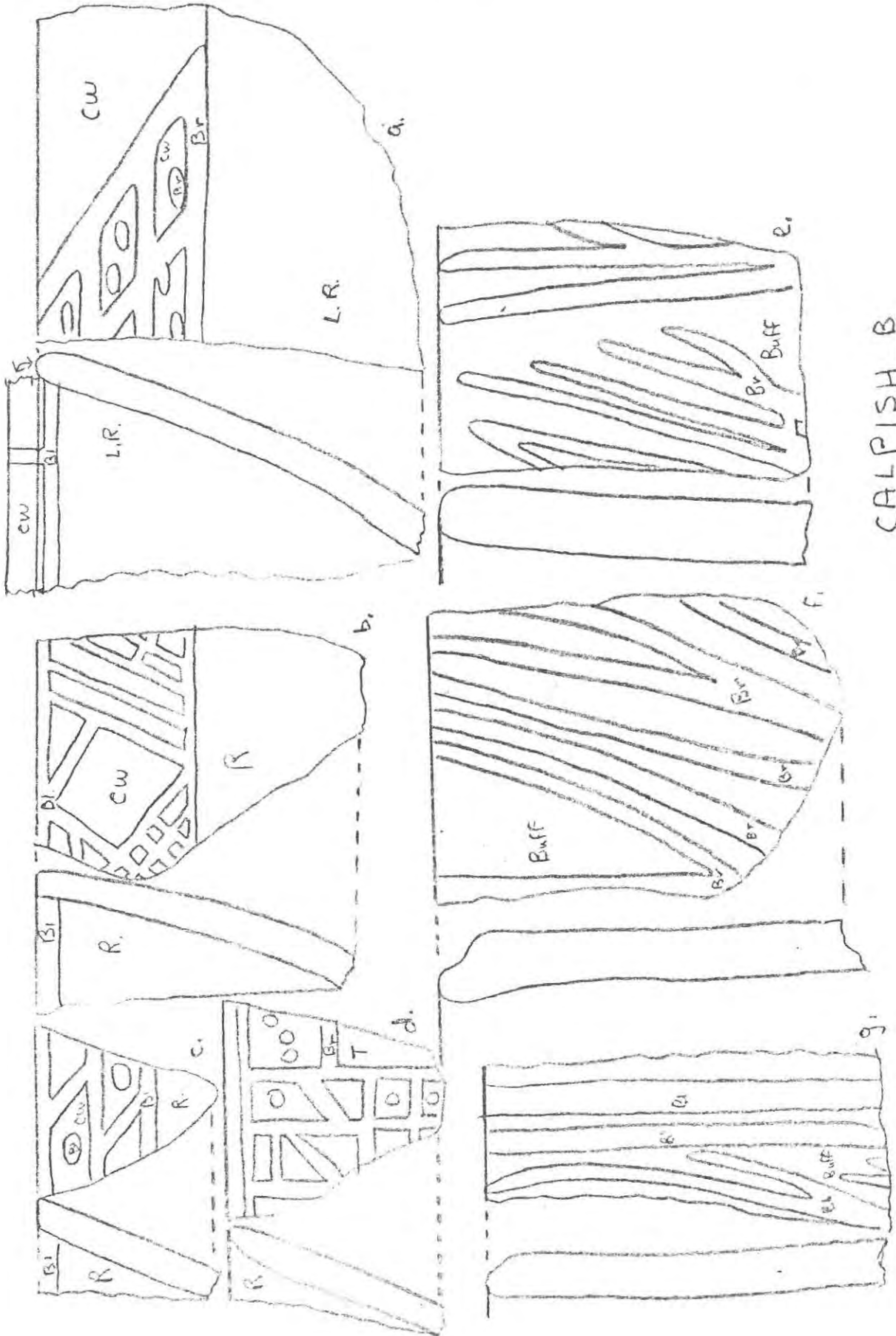

CALPISH B

Fig. 136

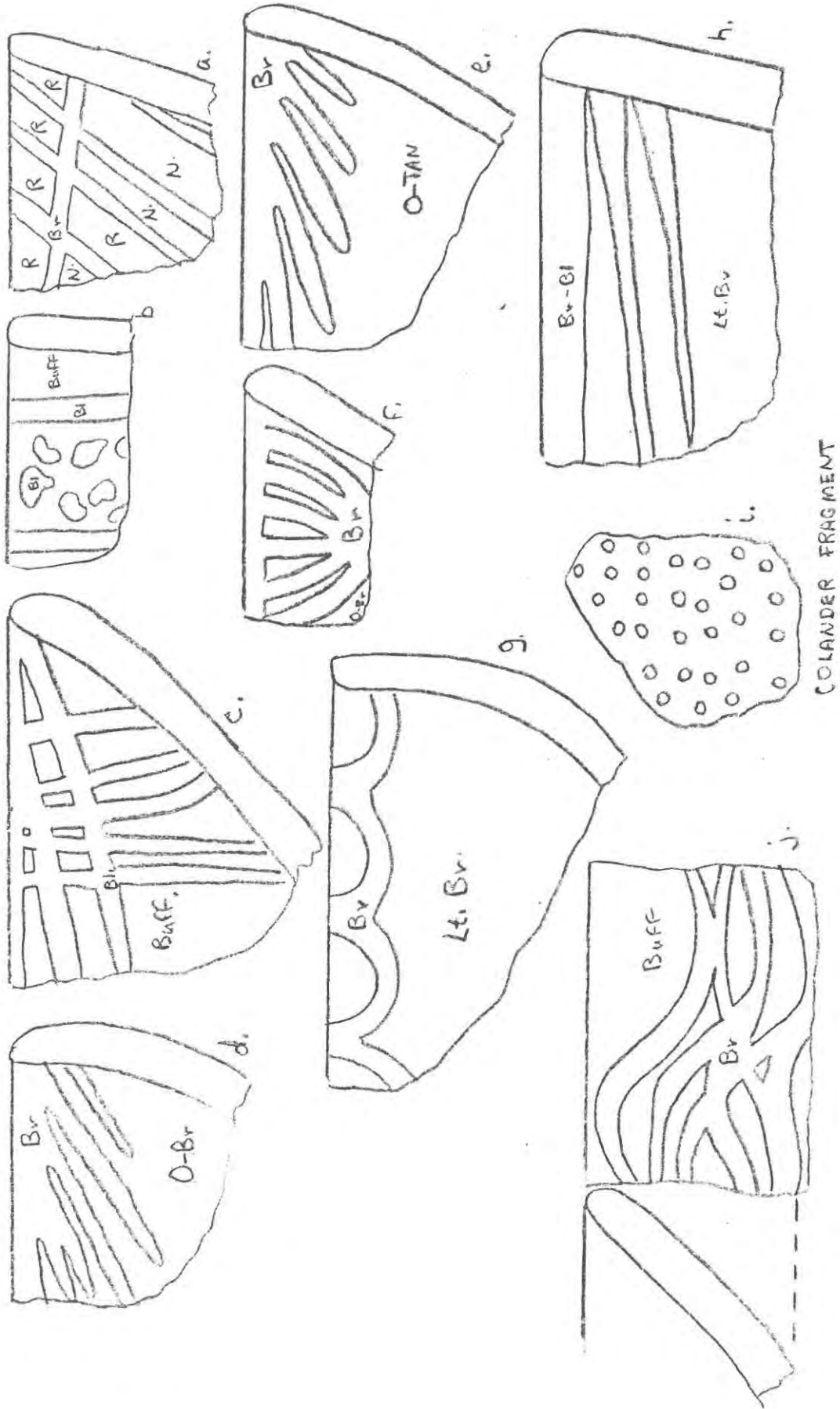

CALPISH C

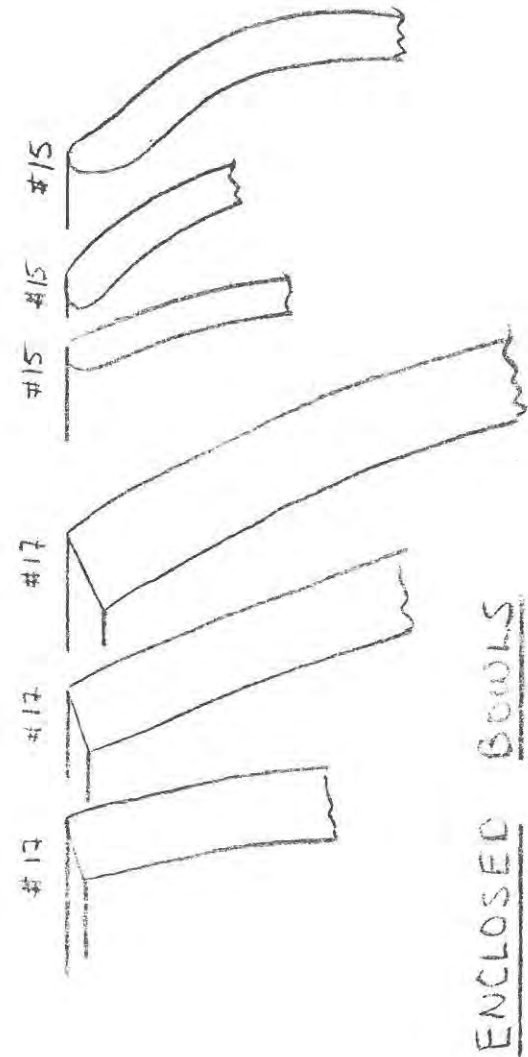
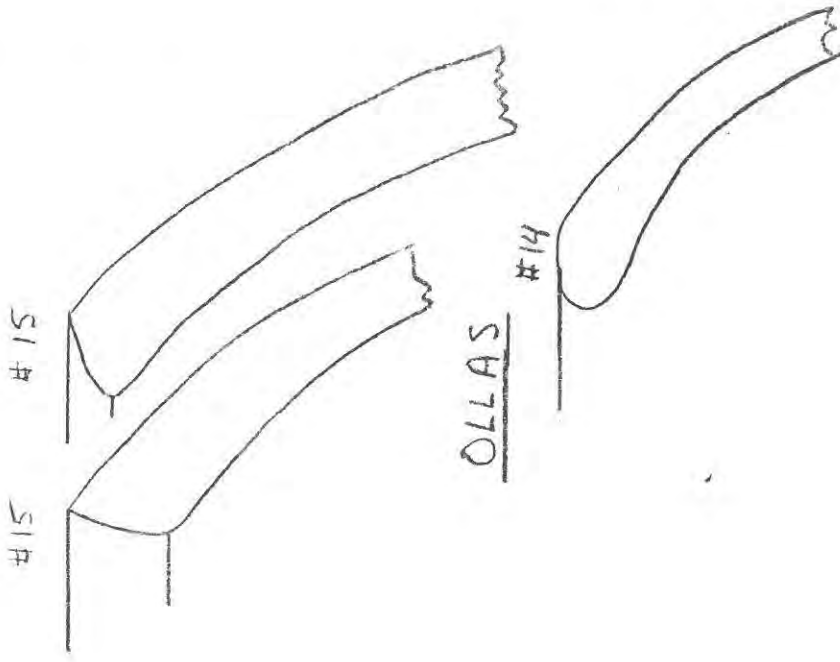

QUINSAHUANCA - VARIOUS

Fig. 138

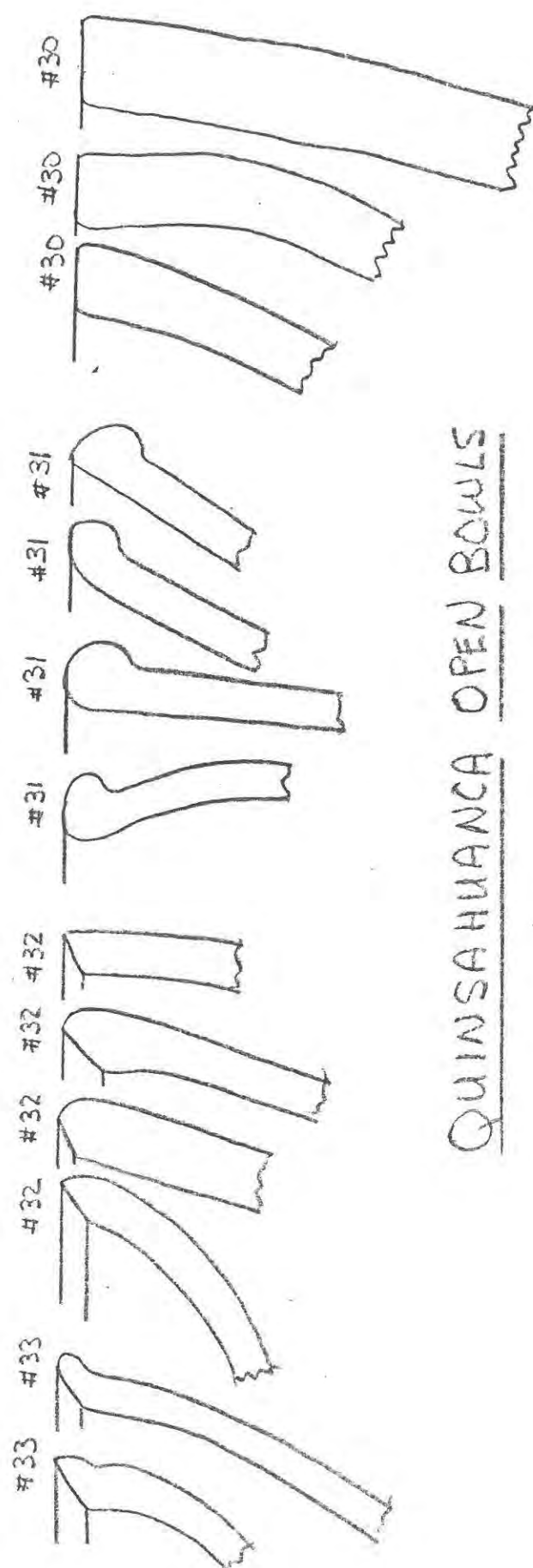
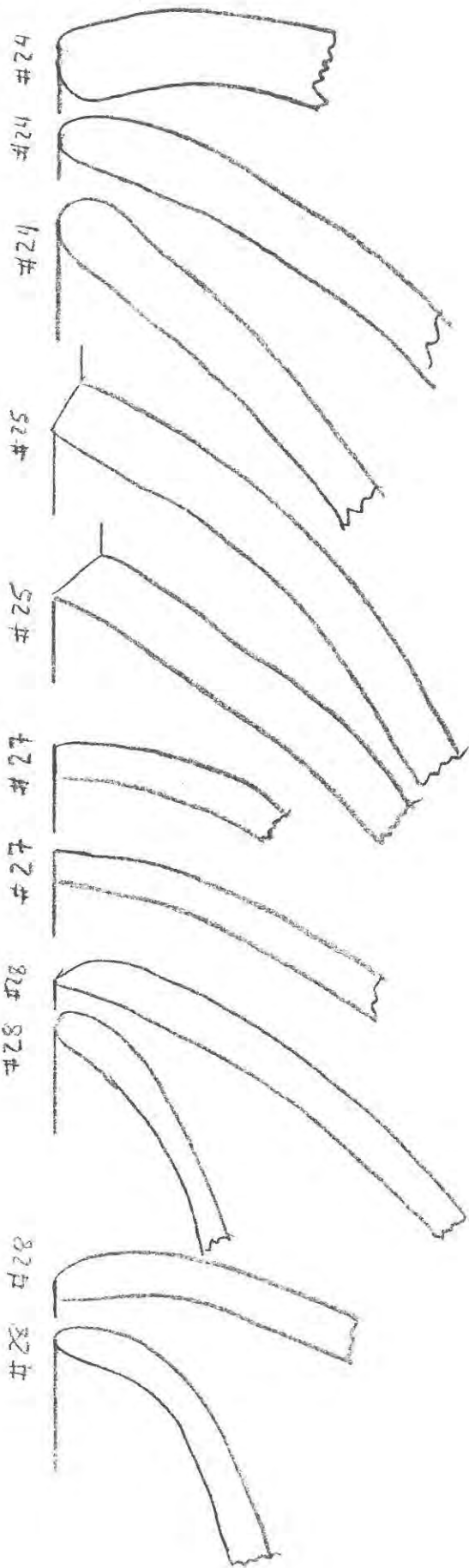

QUINSAHUANCA OPEN BOWLS

Fig. 139

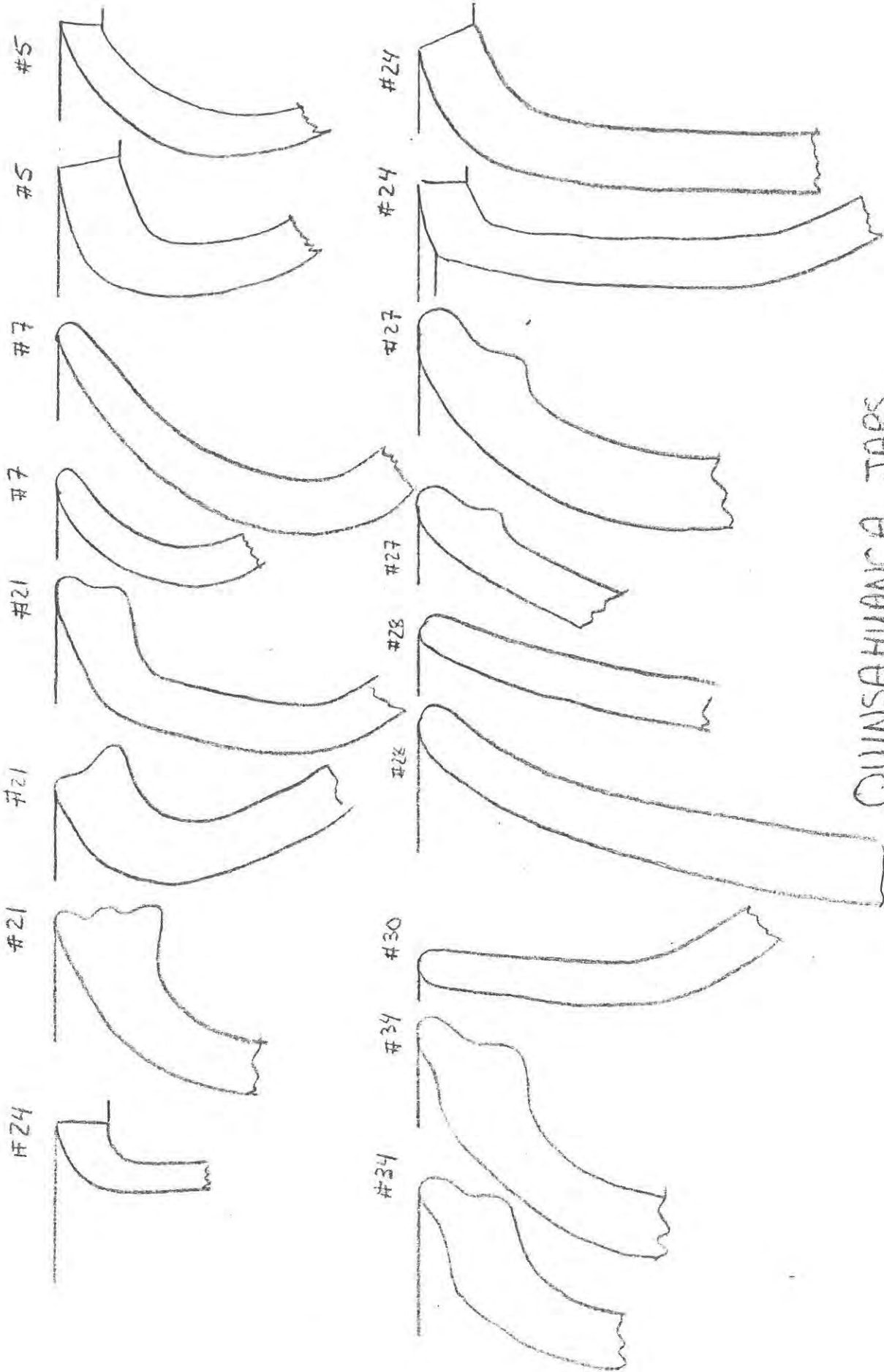

QUINSAHUANCA JARS

Fig. 140

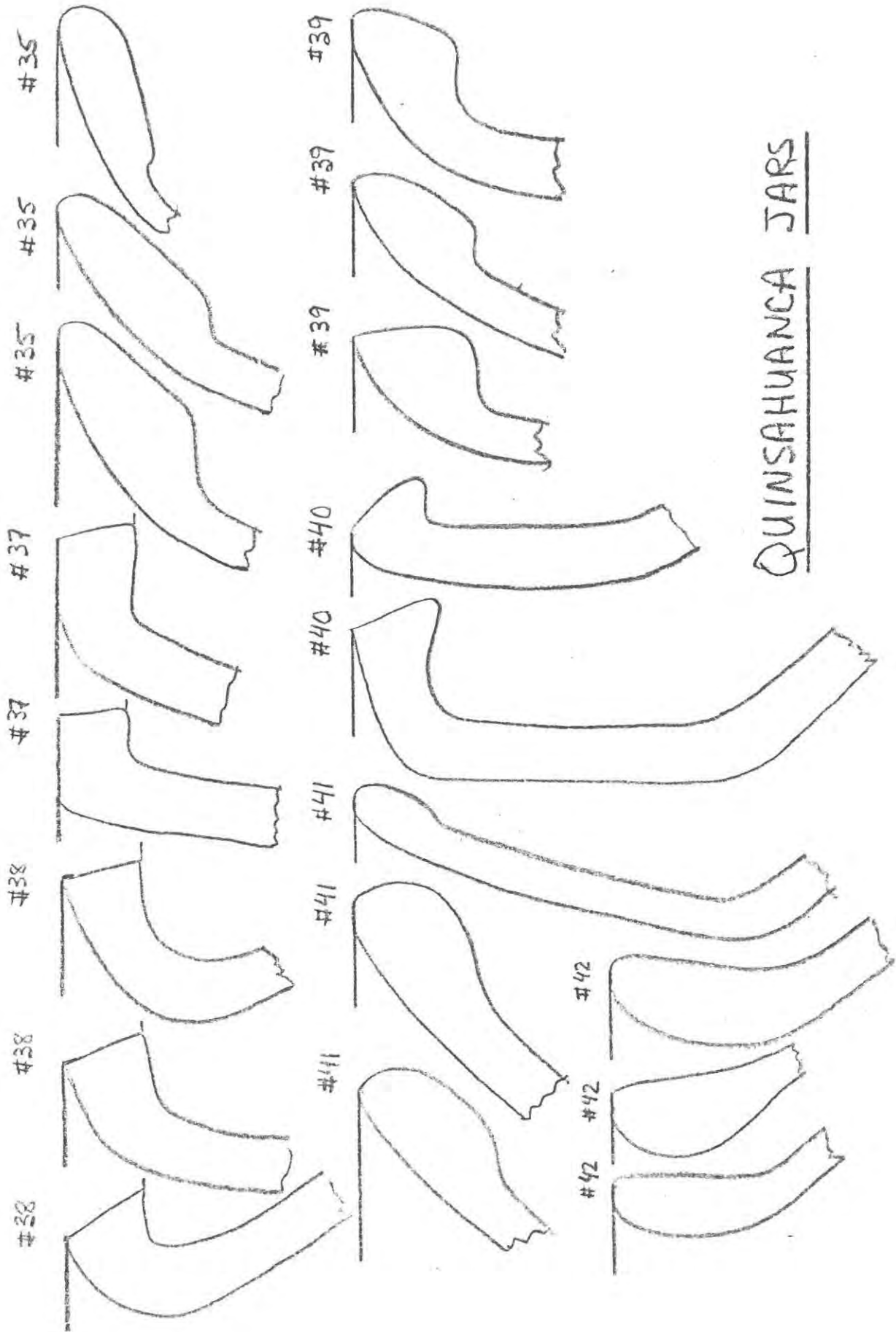

QUINSAHUANCA JARS

Fig. 141

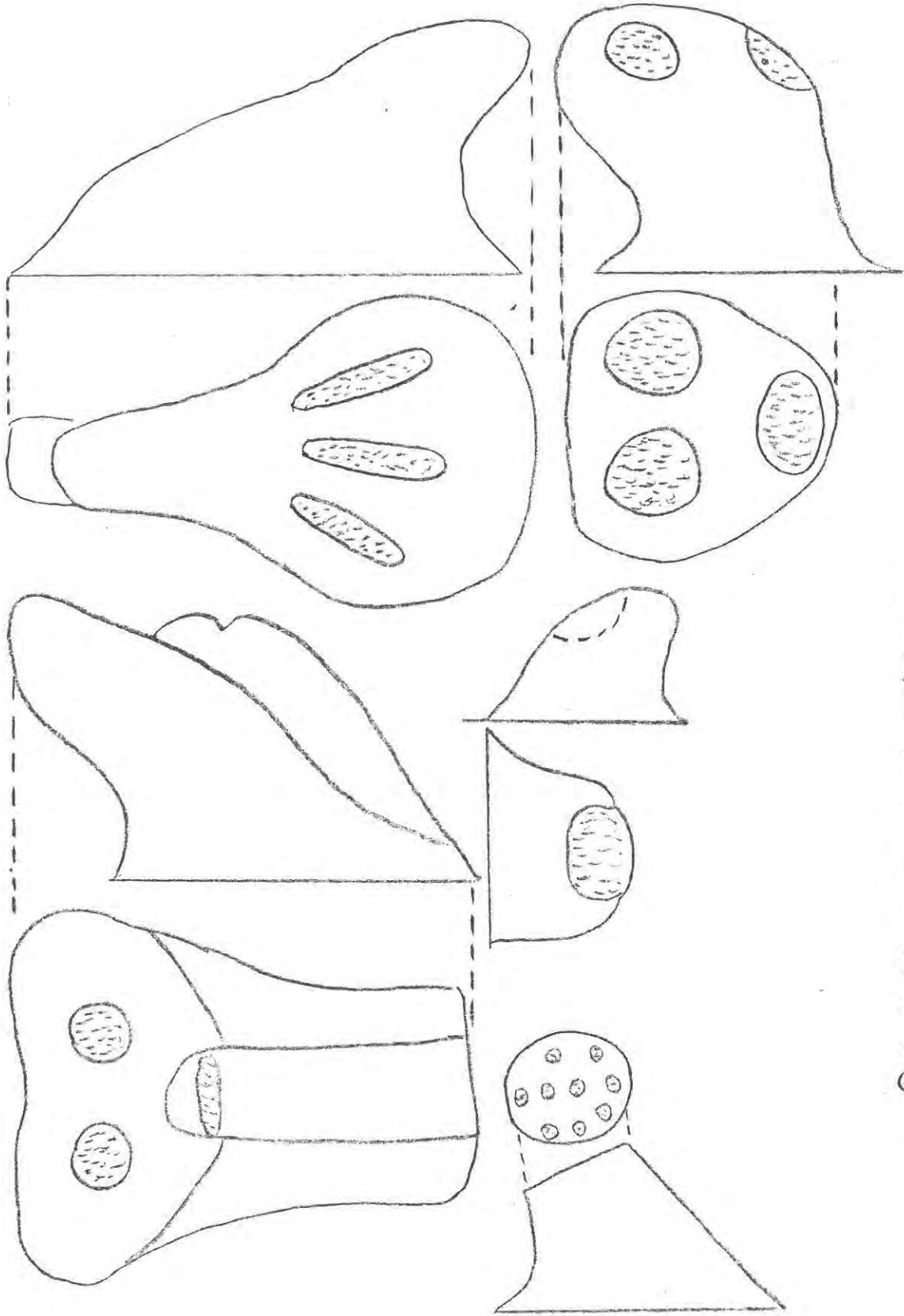

QUINSAHUANCA A JAR LUGS

Fig. 142

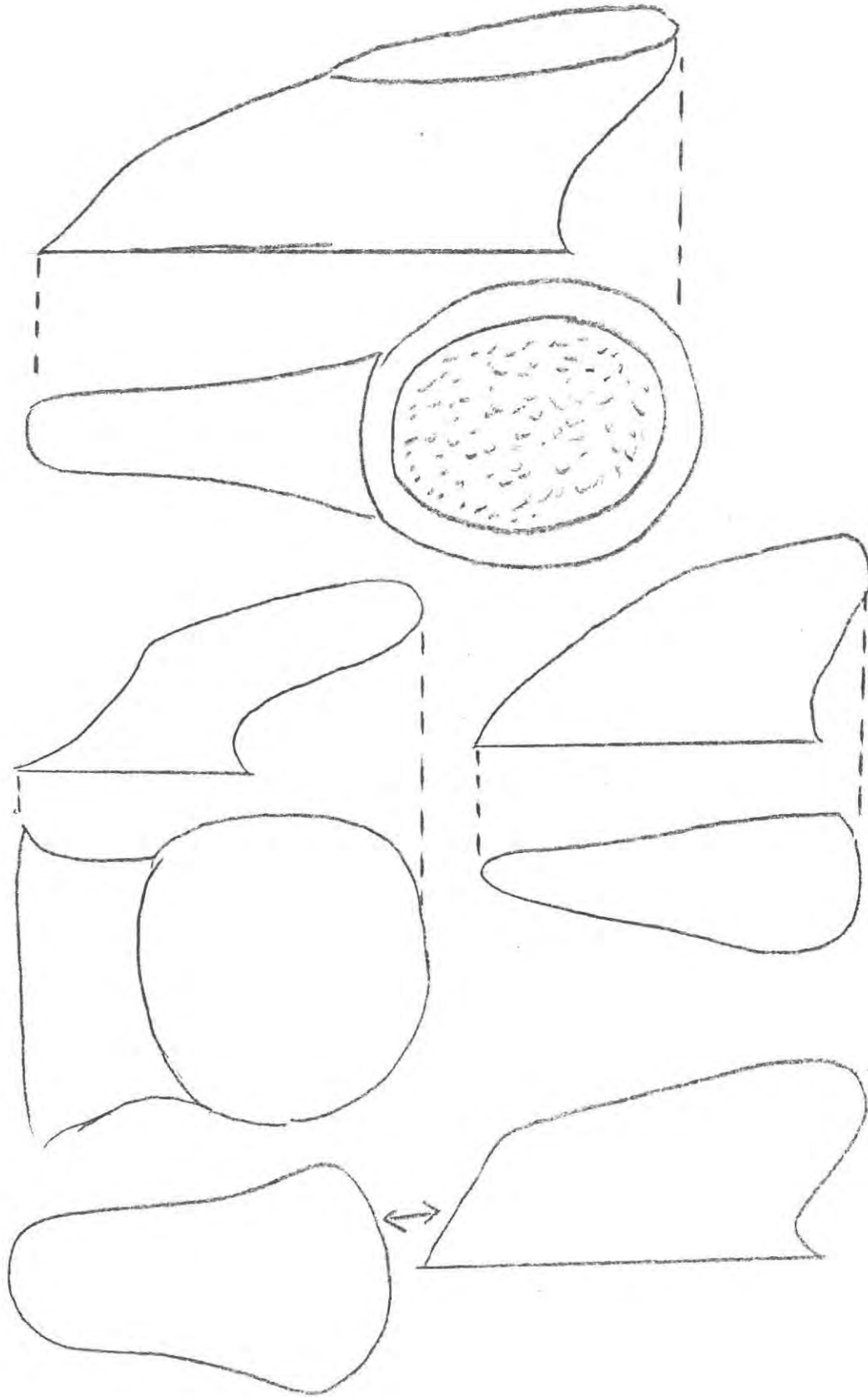

QUINSAHUANCA B LUGS

Fig. 143

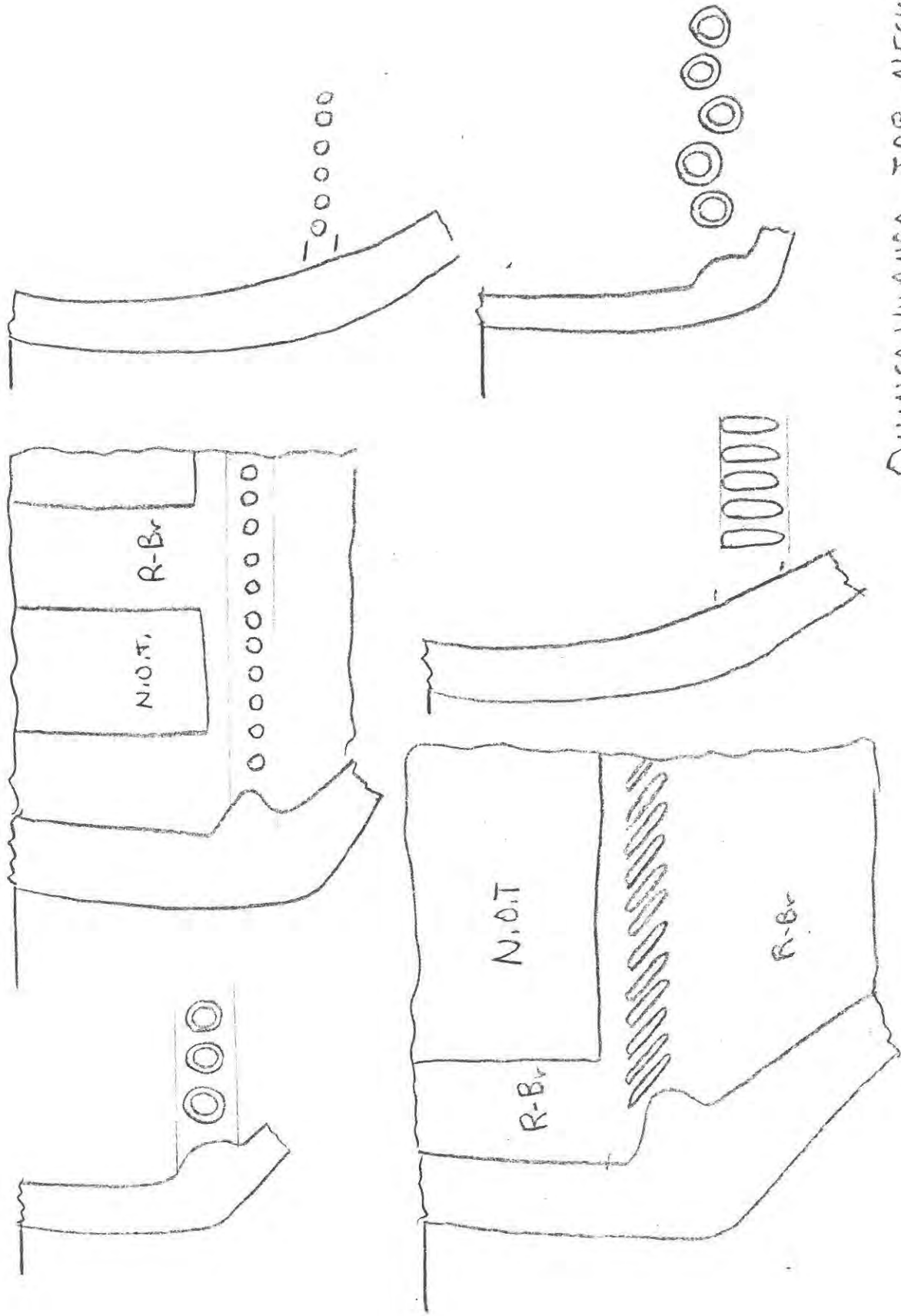

QUINSA HUANCA JAR NECKS

Fig. 144

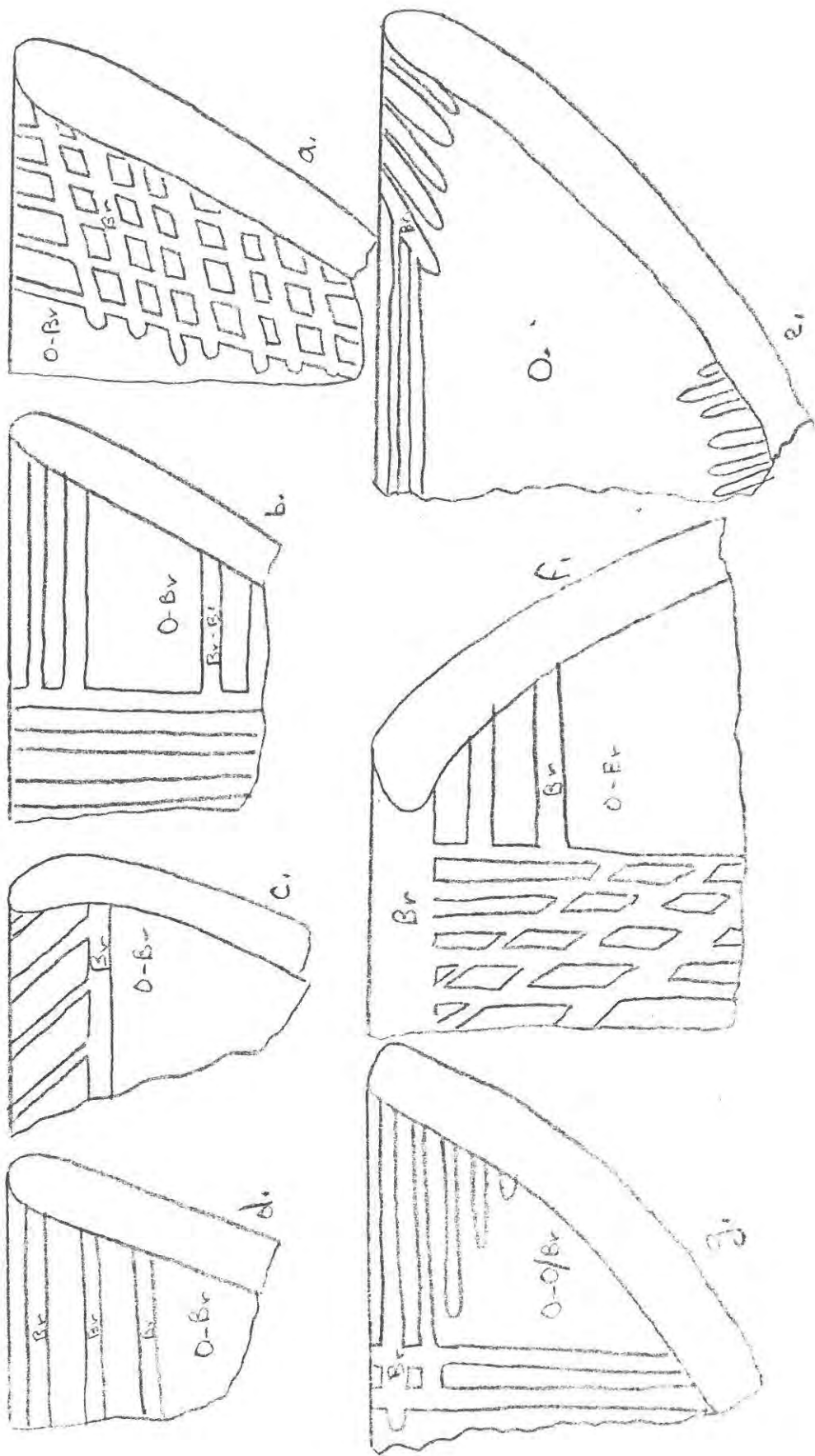

QUINSA HUANCA A

Fig. 145

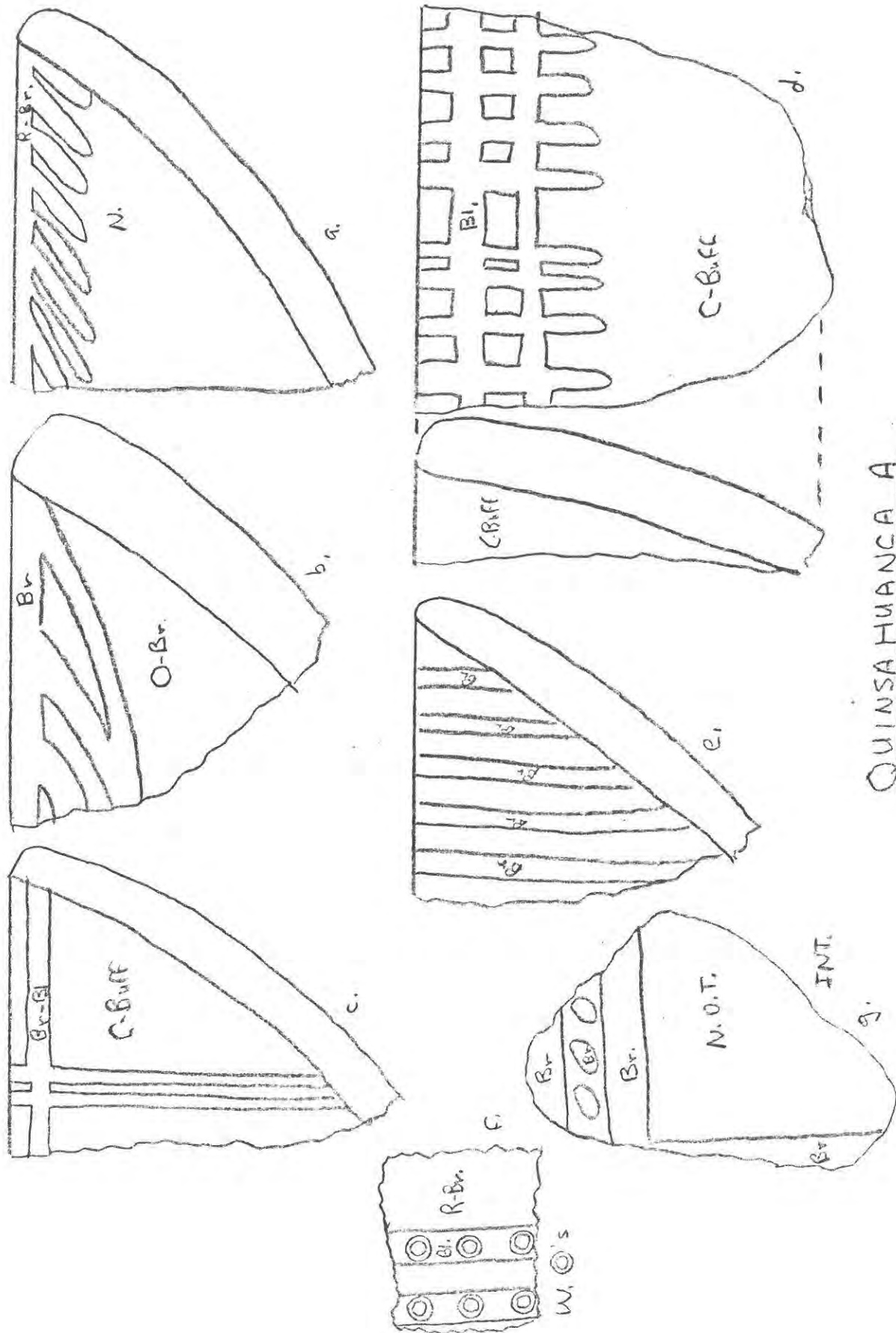

QUINSAHUANCA A

Fig. 146

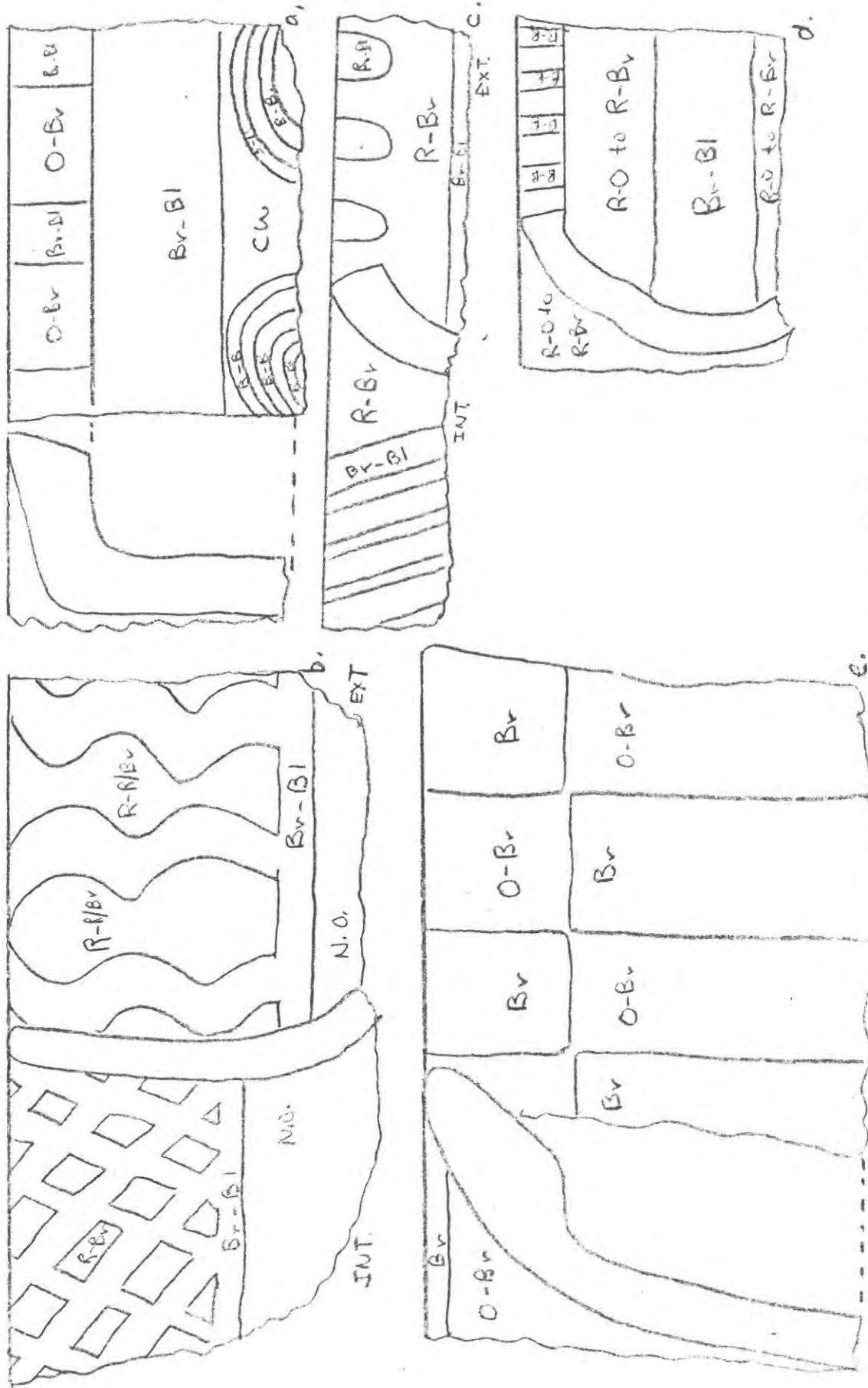

QUINSA HUANCA A

Fig. 147

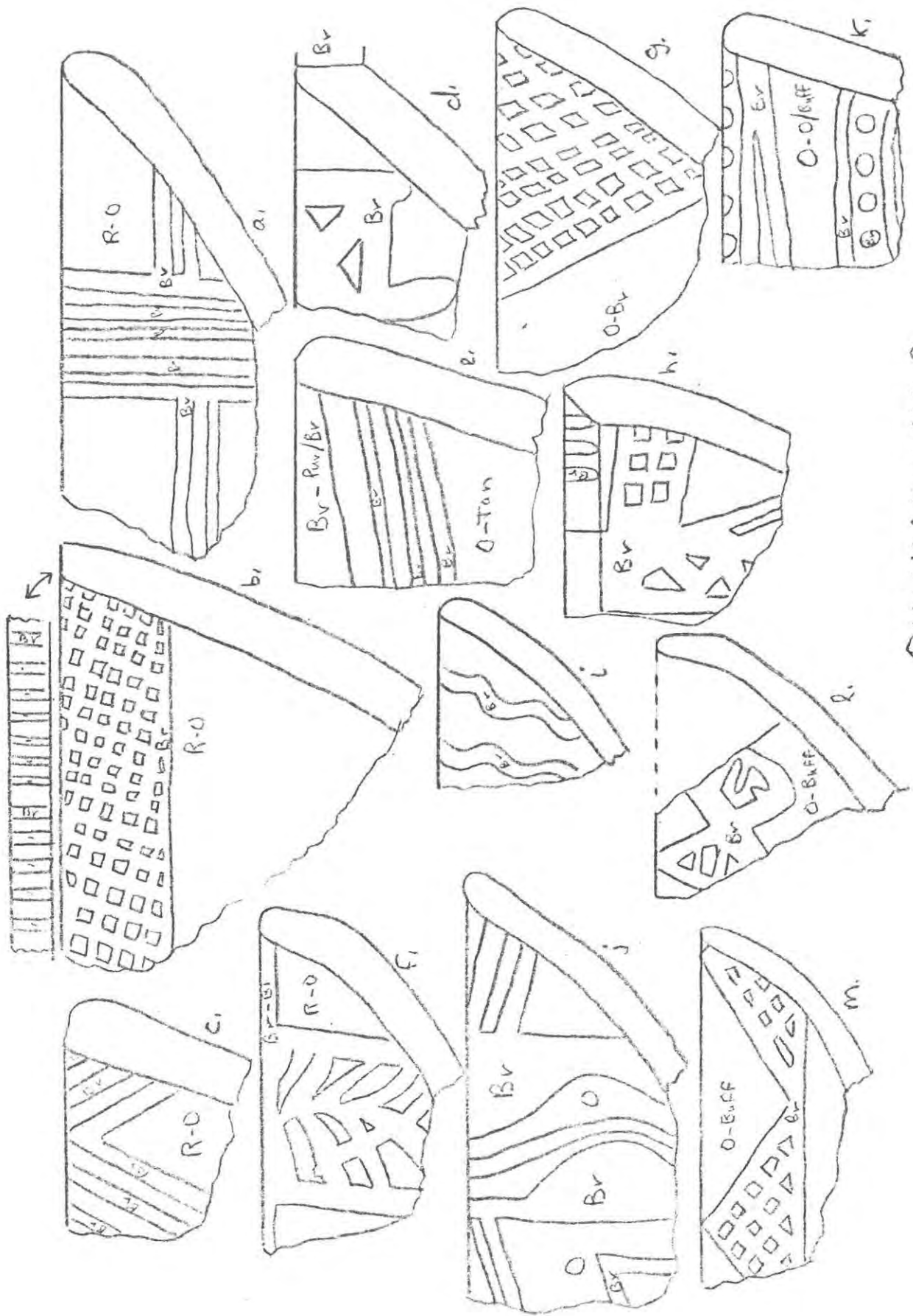

QUINSAHUANCA B

Fig. 148

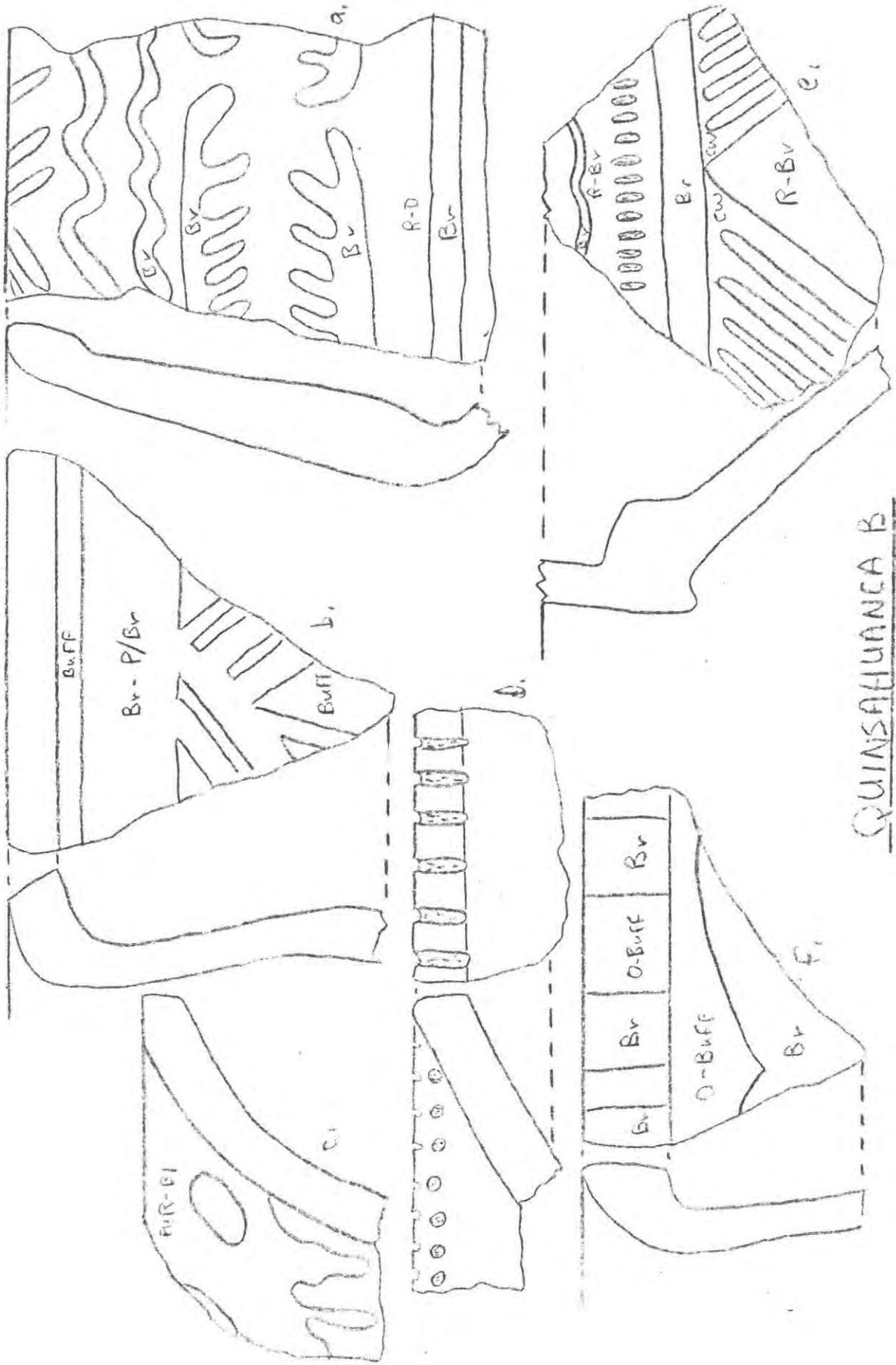

QUINSAHUANCA B

Fig. 149

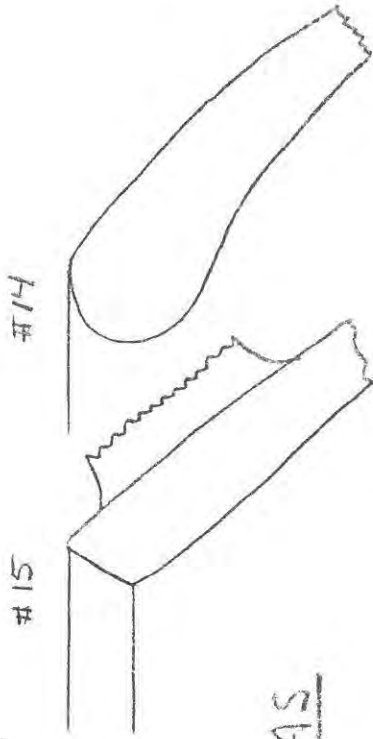

OLLAS

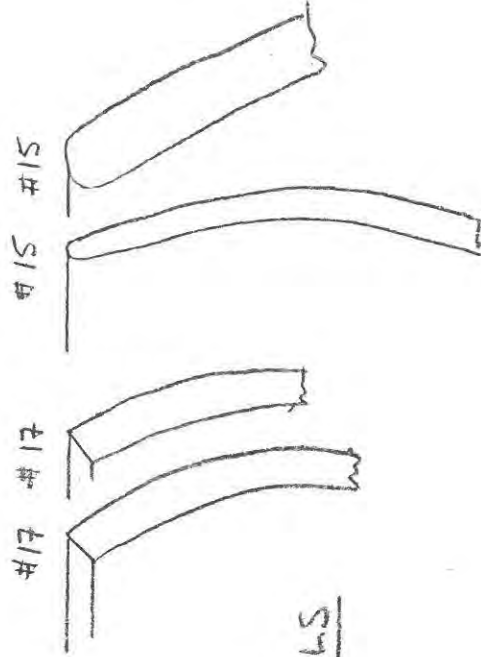

ENCLOSED BOWLS

32cm



LID?

MATAPUQUID - VARIOUS

Fig. 150

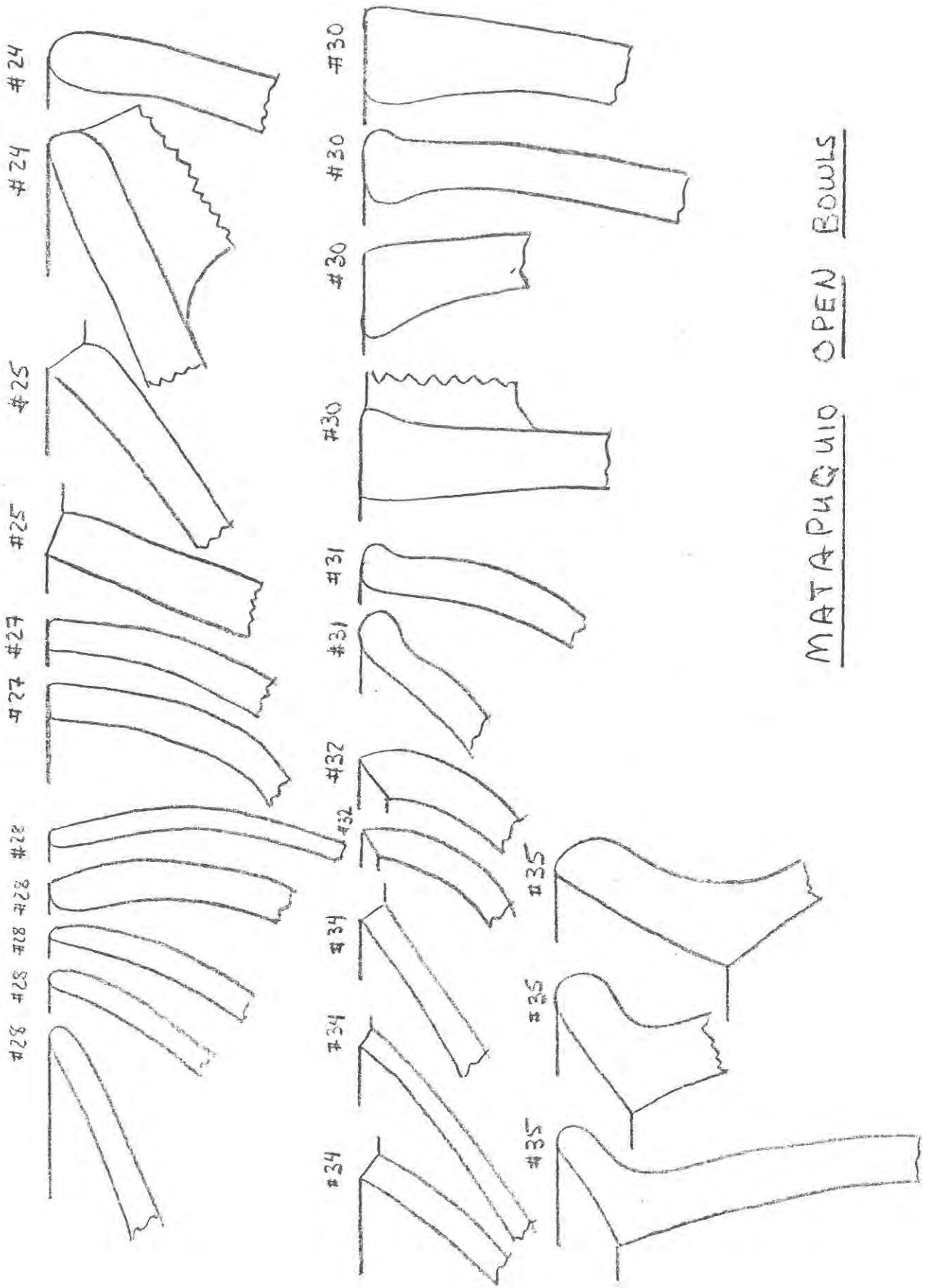

MATAPUQUIO OPEN BOWLS

Fig. 151

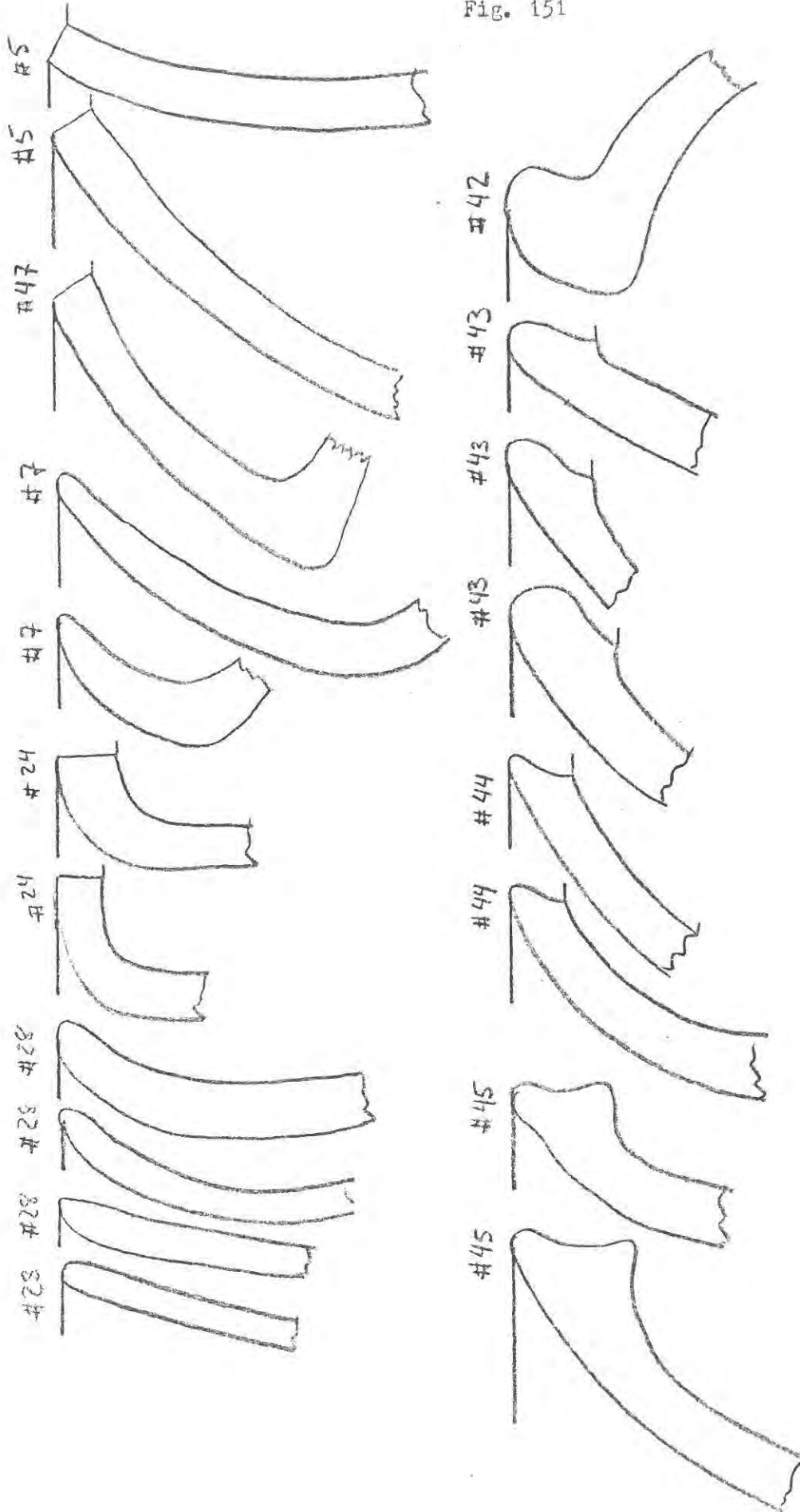

MATAPUQUIC JARS

Fig. 152

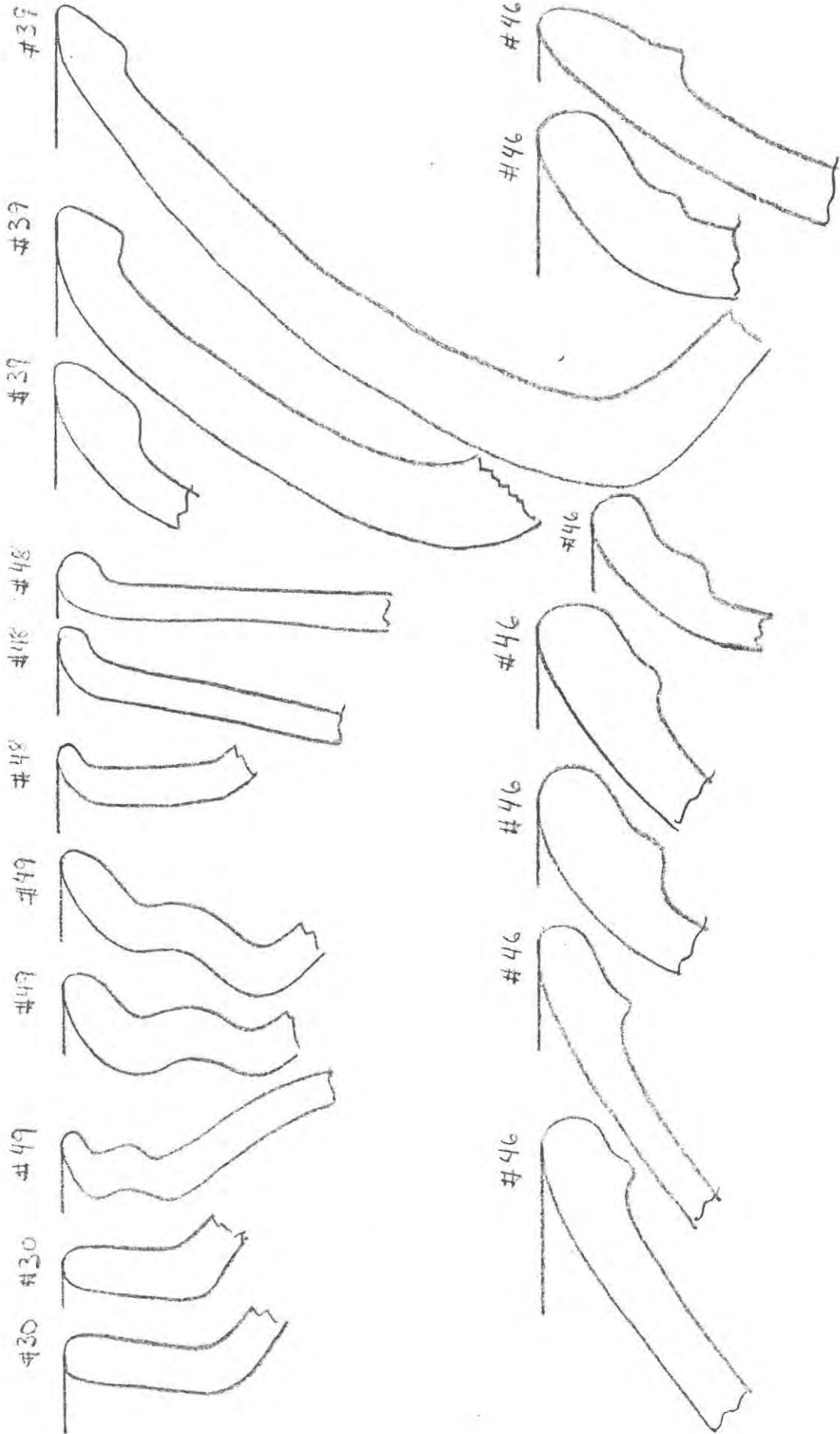

MATAPUQUIO - JARS

Fig. 153

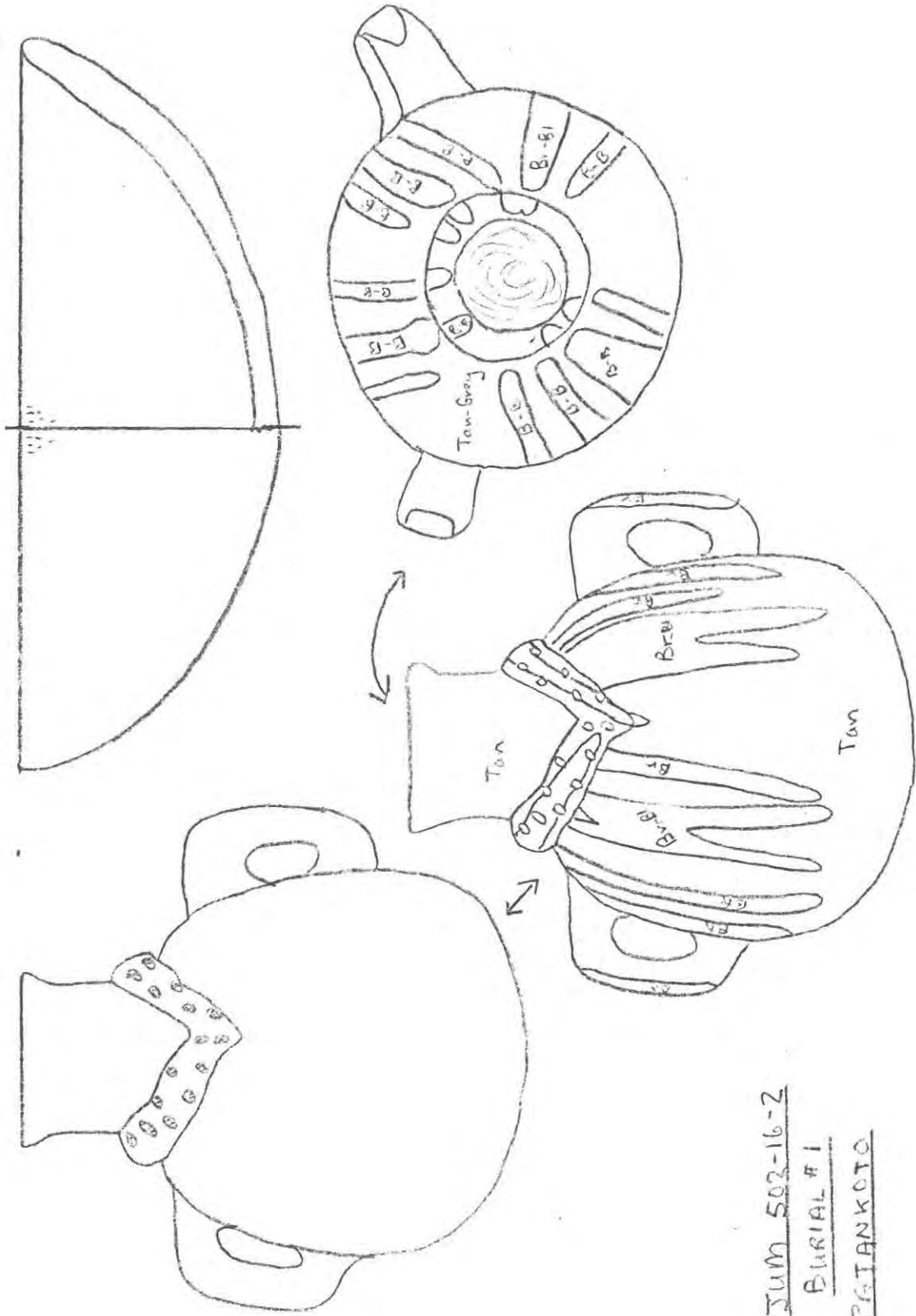

PJUM 502-16-2
BURIAL #1
PGIANKOTO

MATAPIKQIIO

Fig. 154

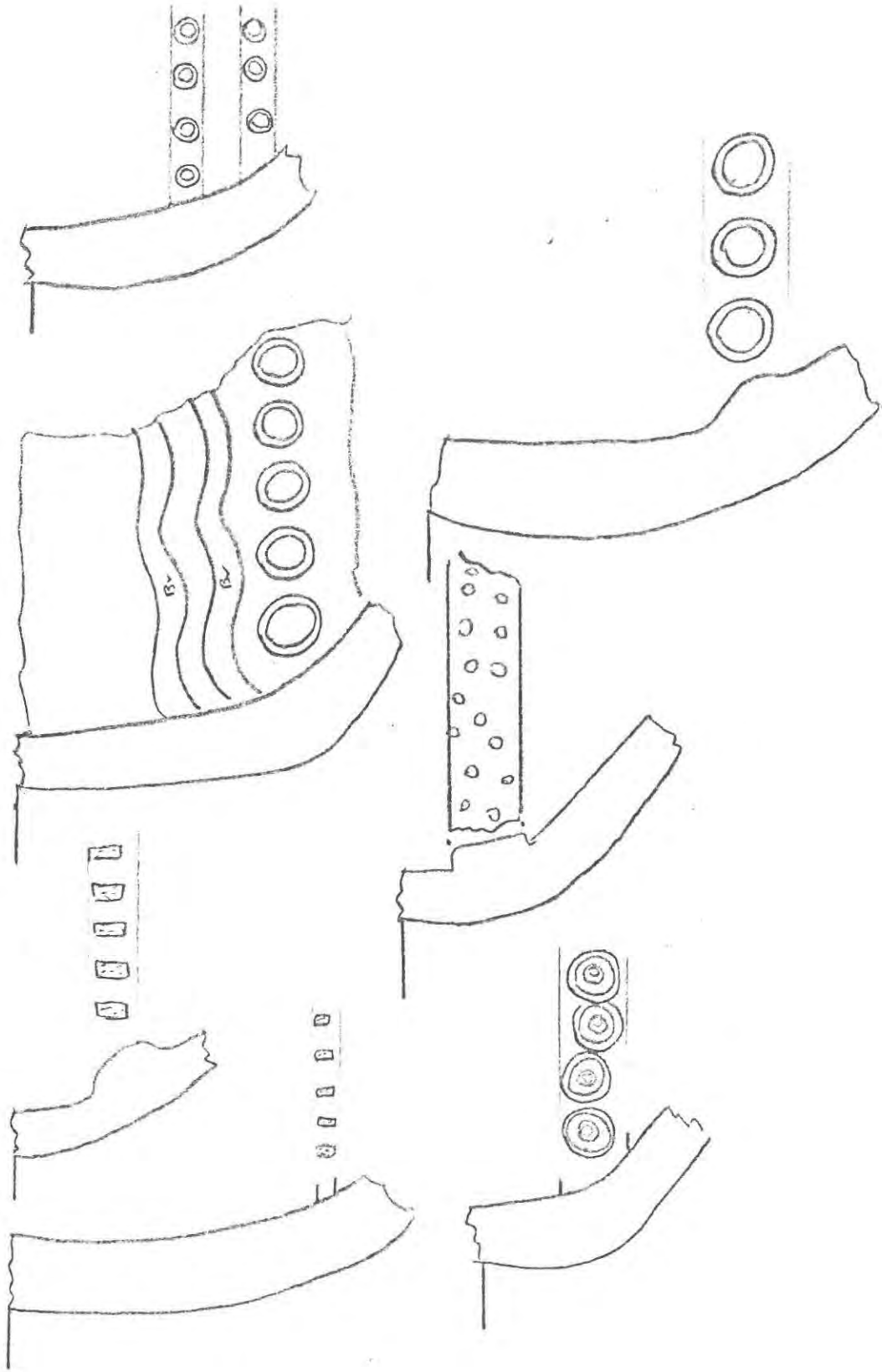

MATAPUQUID JAR NECK DECORATION

Fig. 155

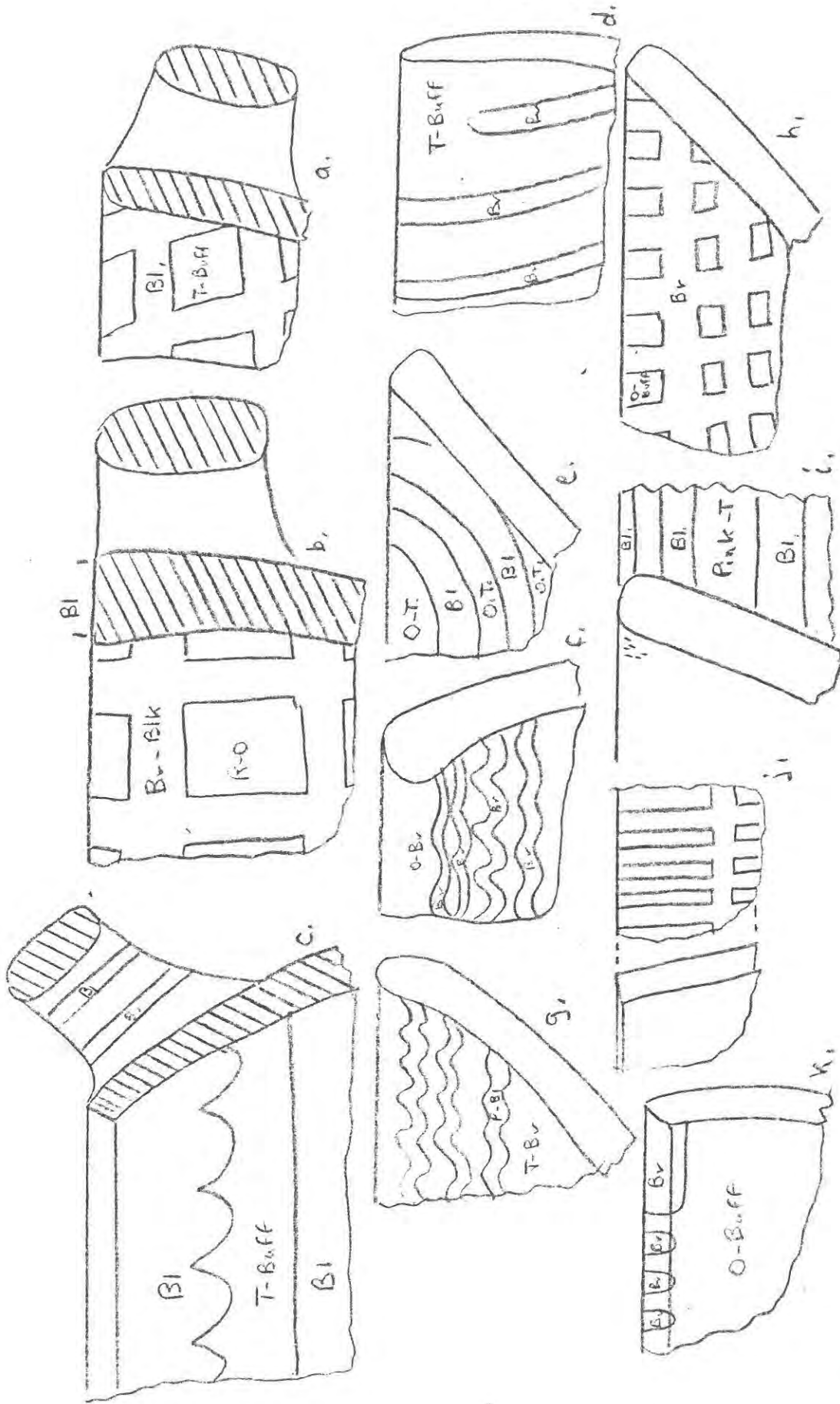

MATA PUQUIO

Fig. 156

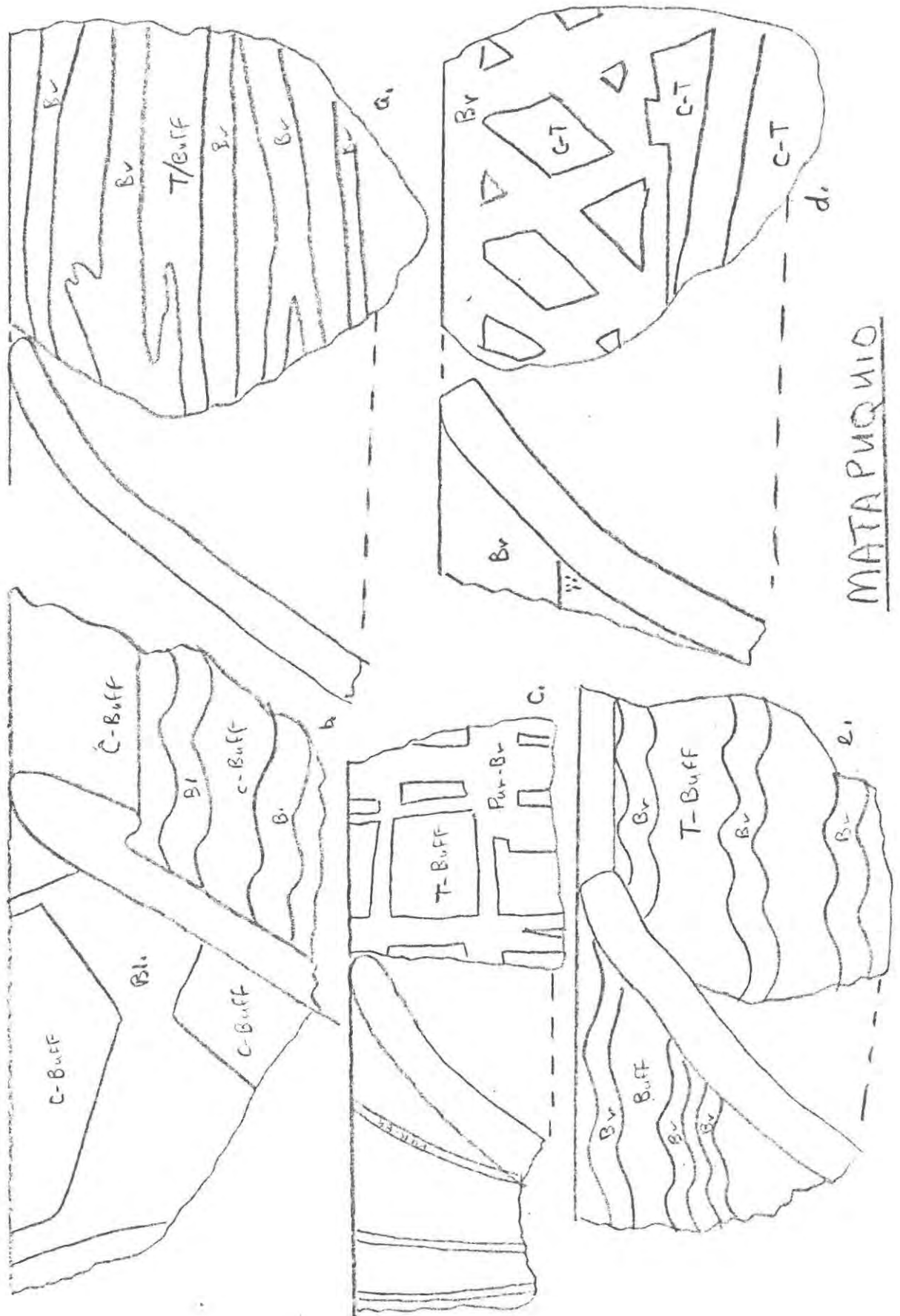

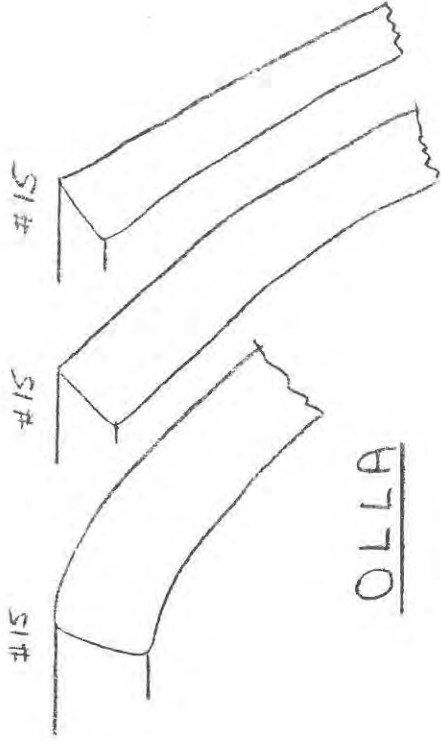

OLLA

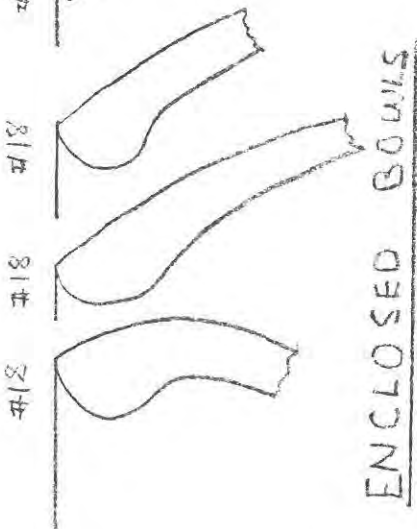
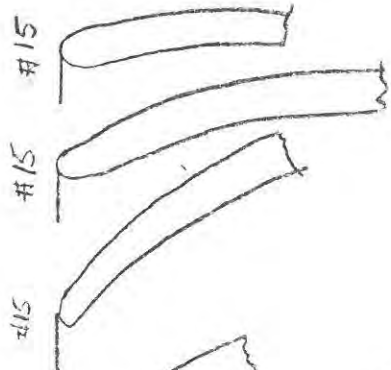

ENCLOSED BOWLS

ARHUATURO - VARIOUS

Fig. 158

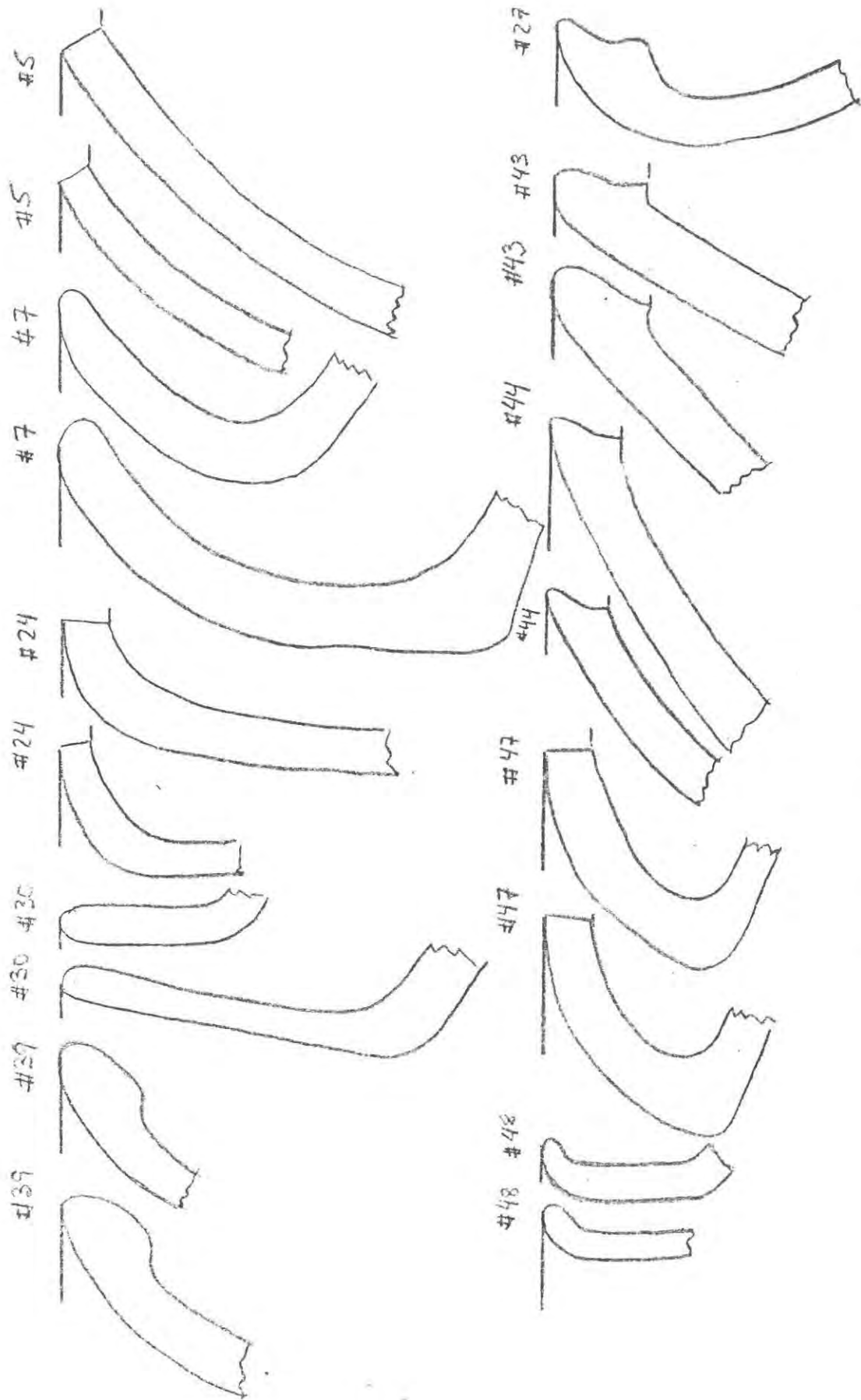

ARHUATURO JARS

Fig. 159

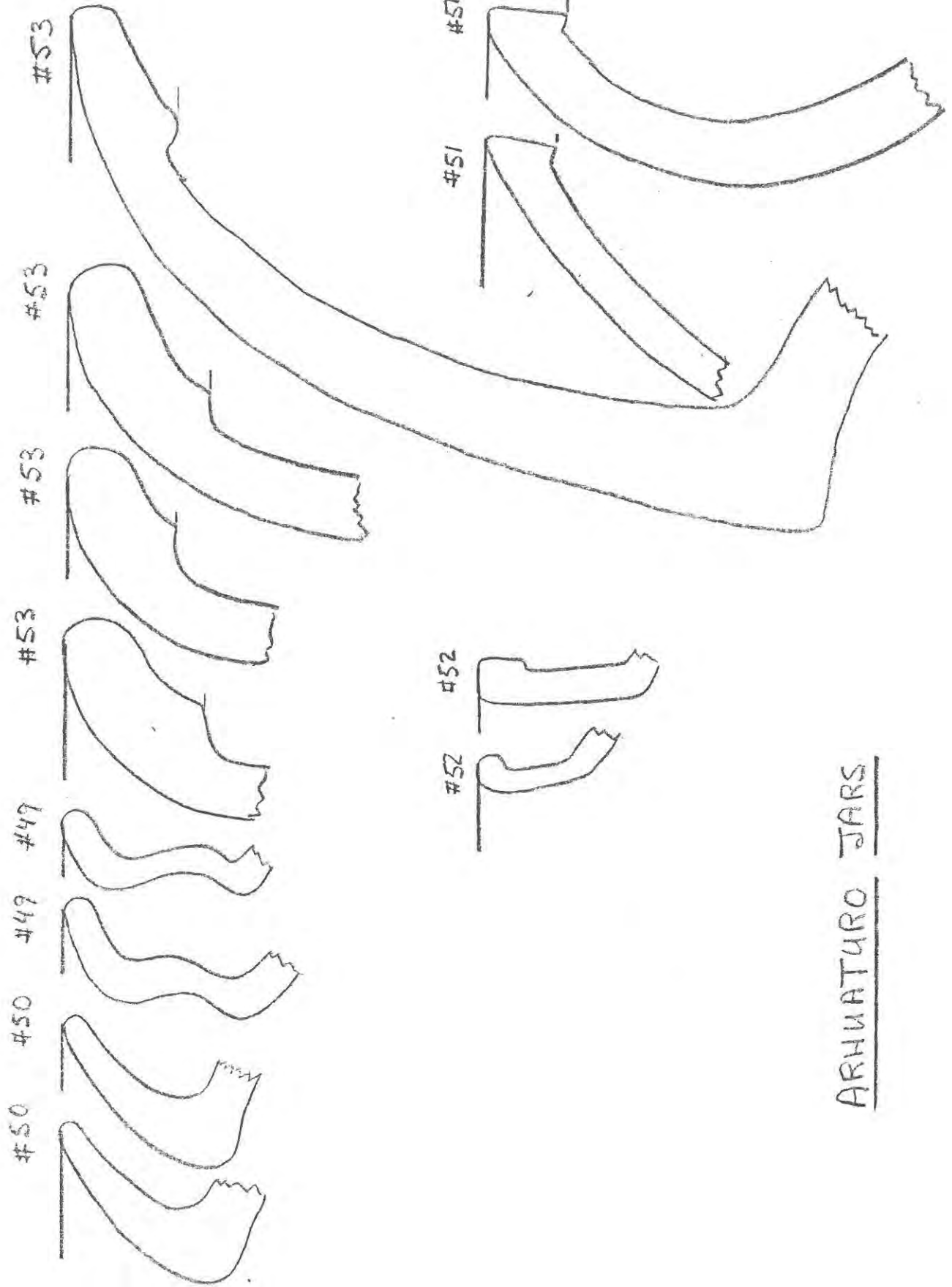

ARHUATURO JARS

Fig. 160

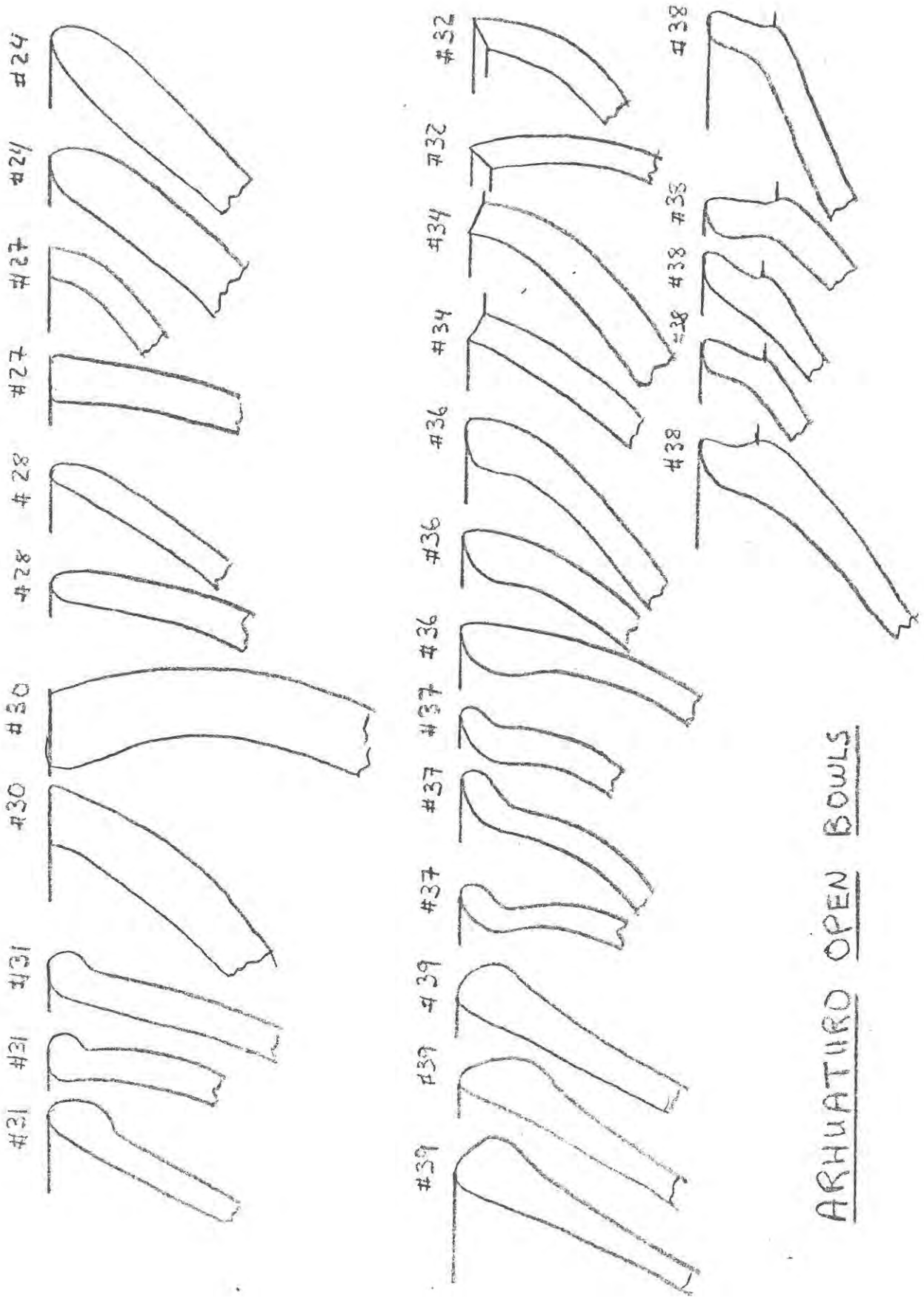

ARHUATURO OPEN BOWLS

Fig. 161

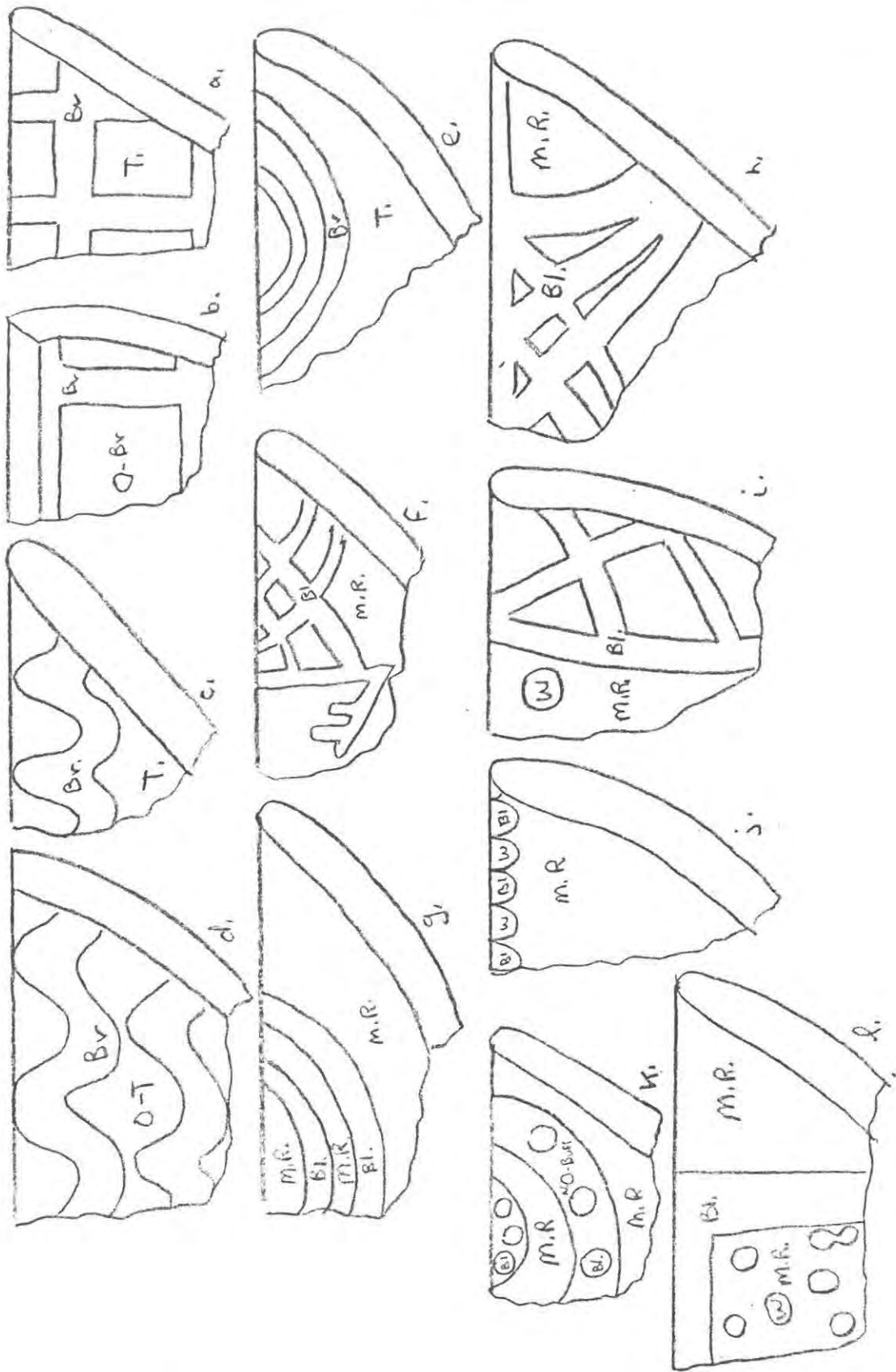

ARHUATURO

Fig. 162

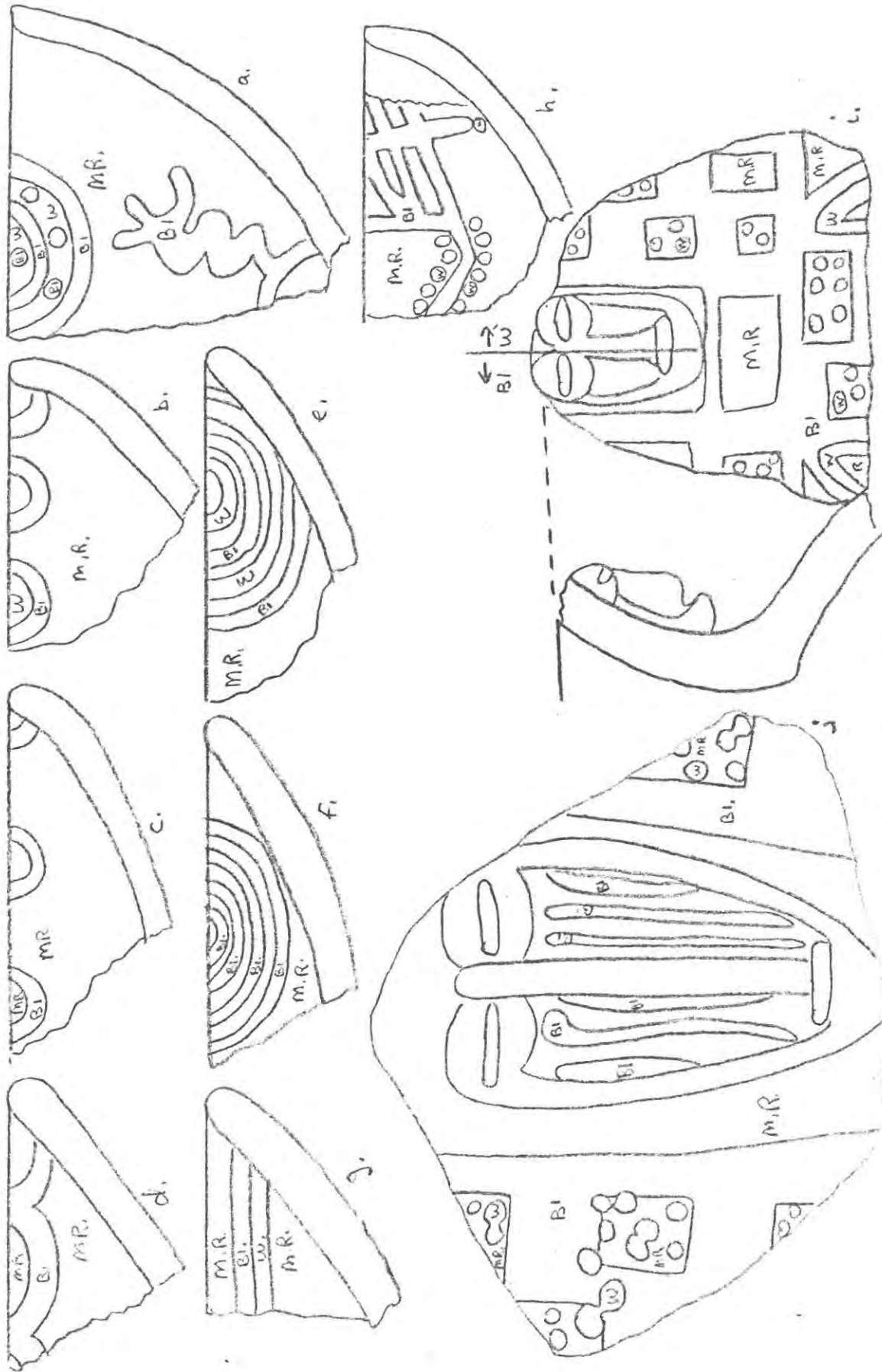

ARHUATURO

Fig. 163

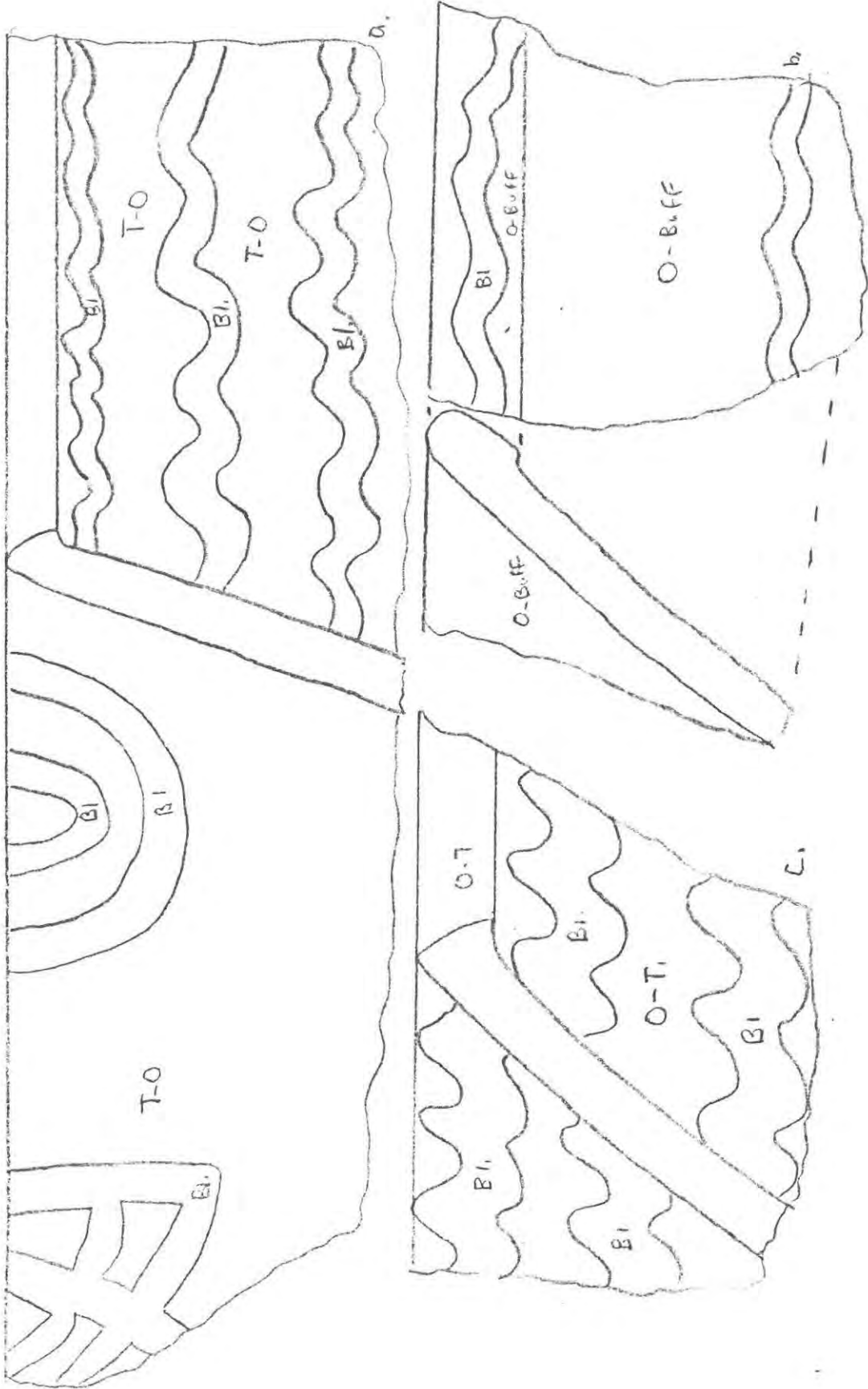

ARHUATURO

Fig. 164

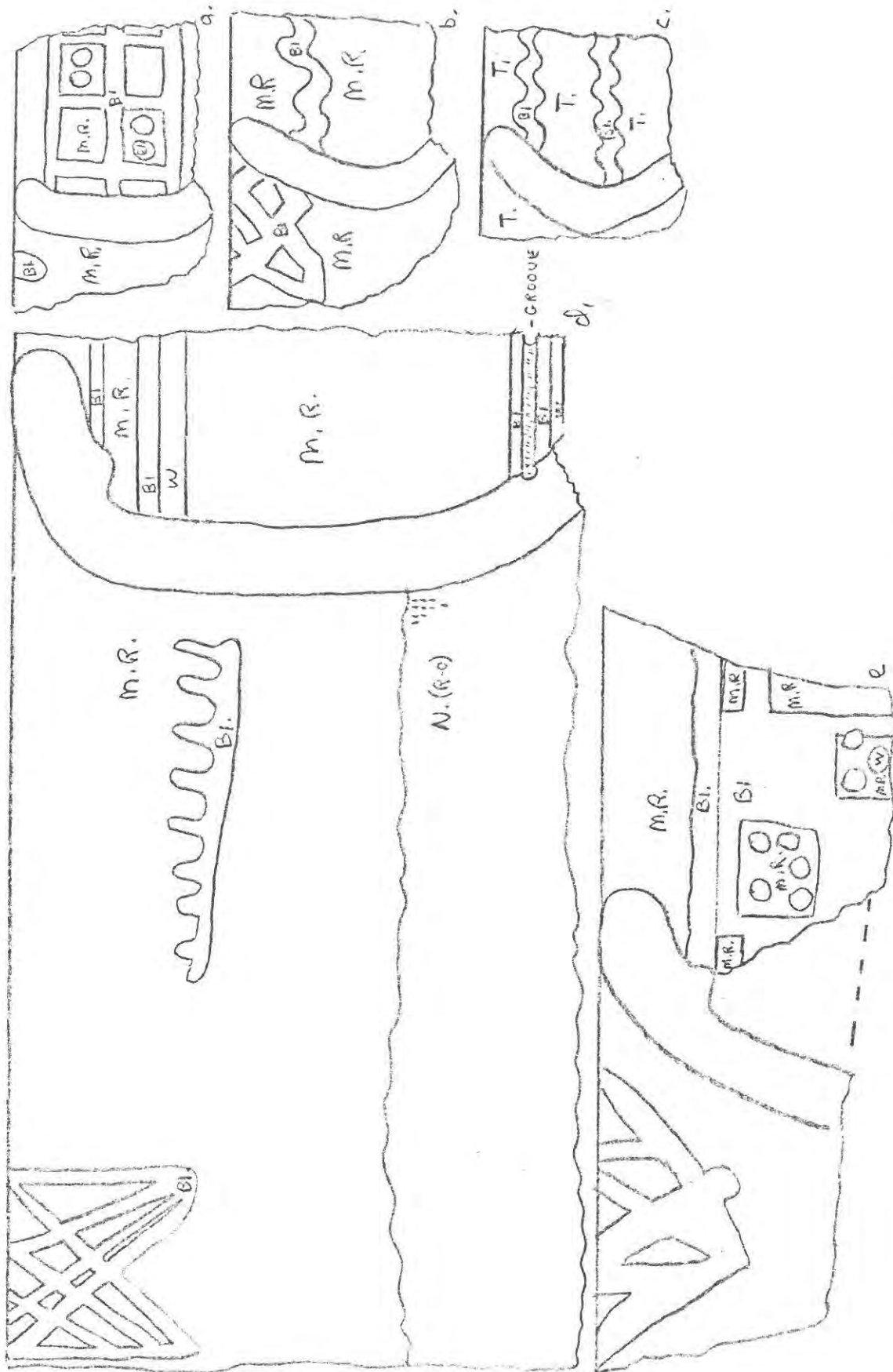

ARHUATURO

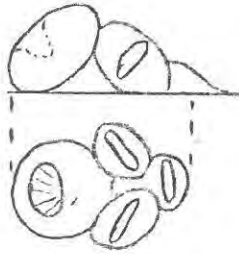
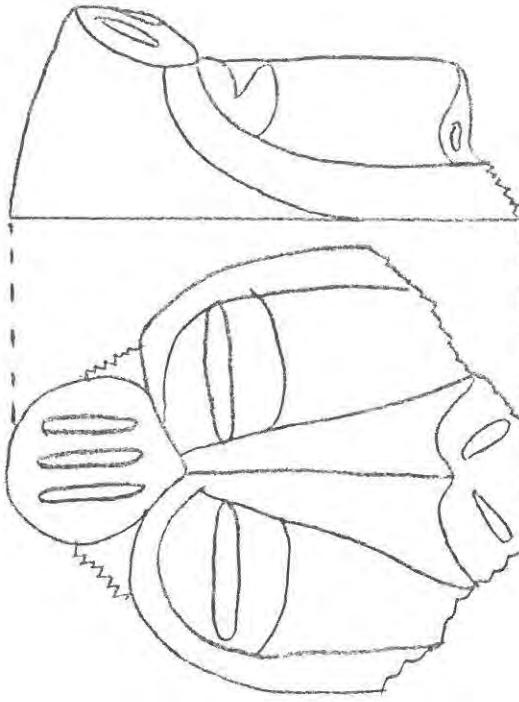

TYPE #1

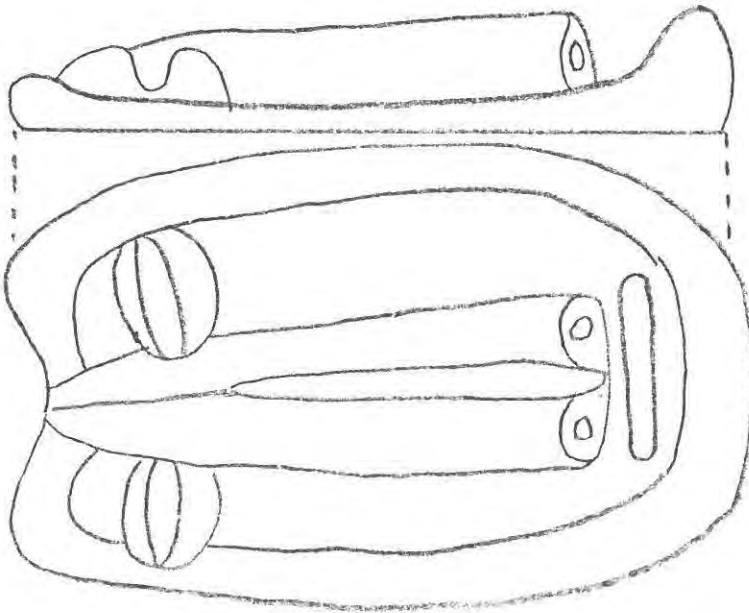

TYPE #2

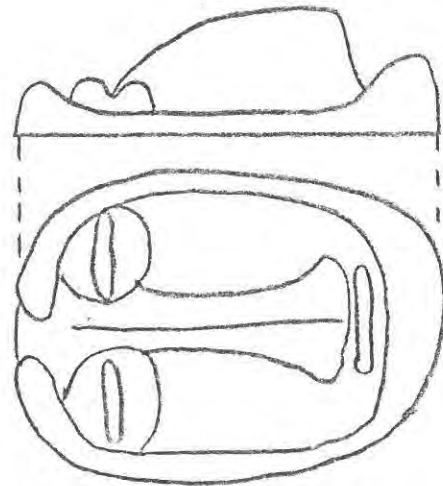

ARHUATURO FACES

TYPE #2

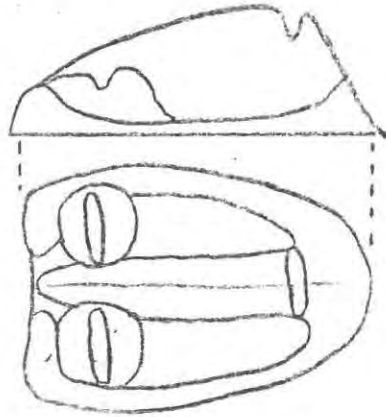
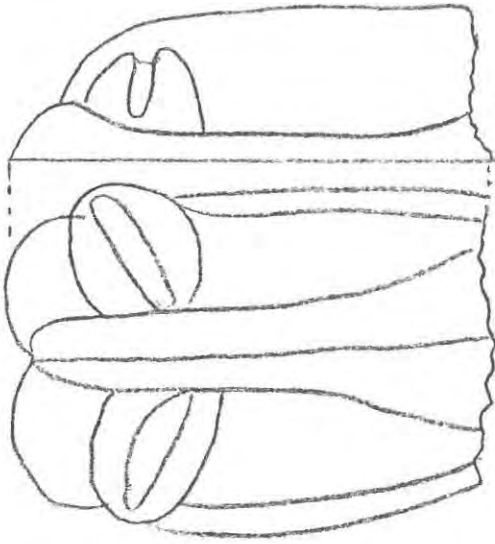

TYPE #3

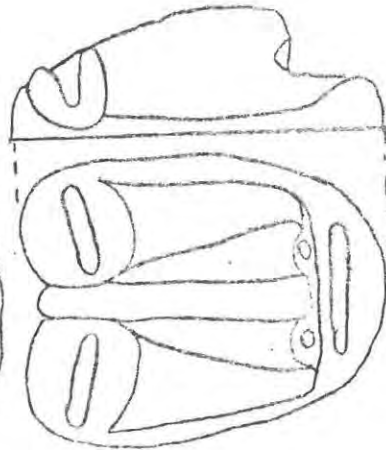
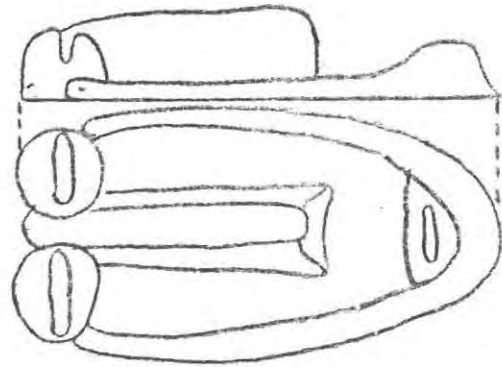
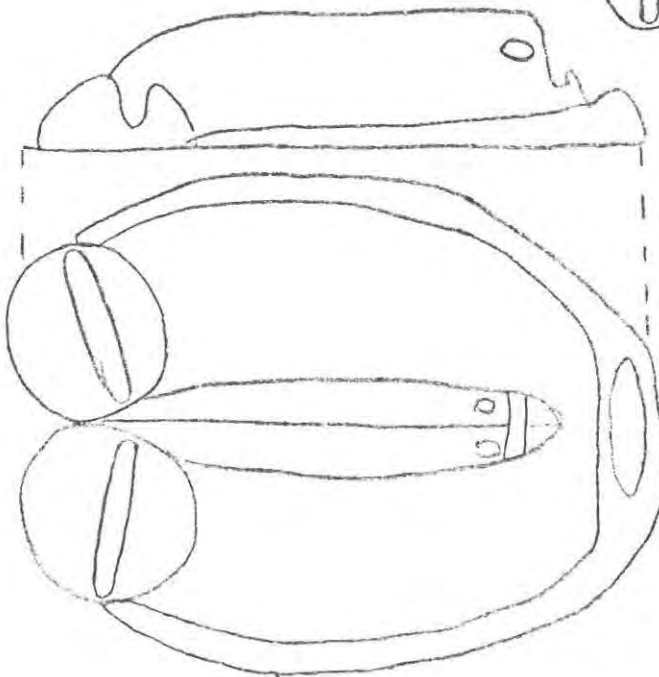

ARHUATURO FACES

Fig. 167

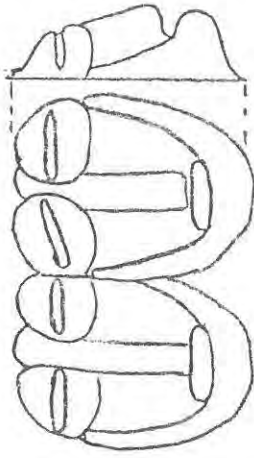

TYPE #3

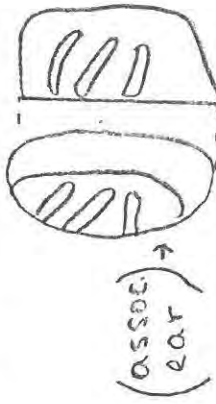

(OSSDC)
(ROR) →

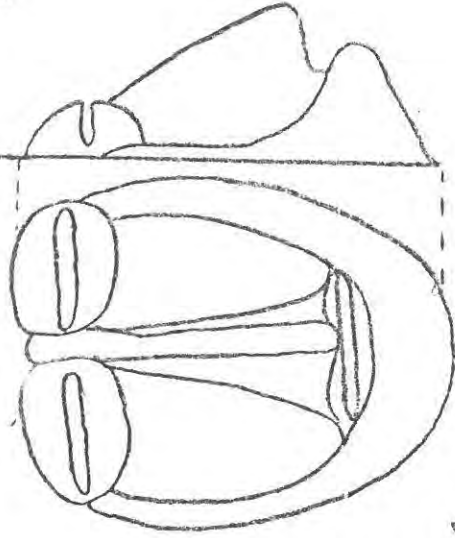

ARHWATURO - FACES, EARS

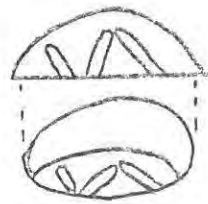
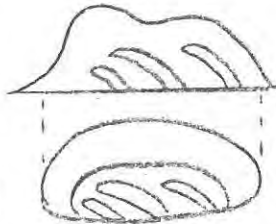
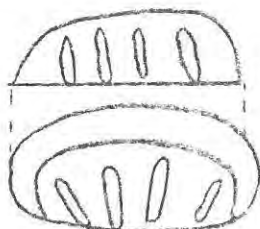
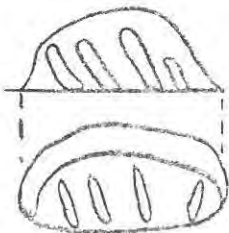
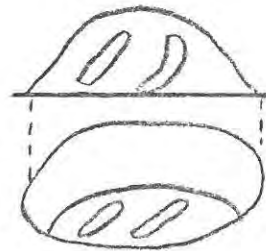
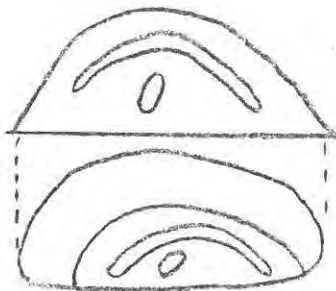
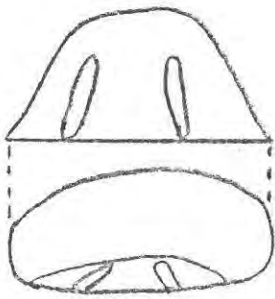
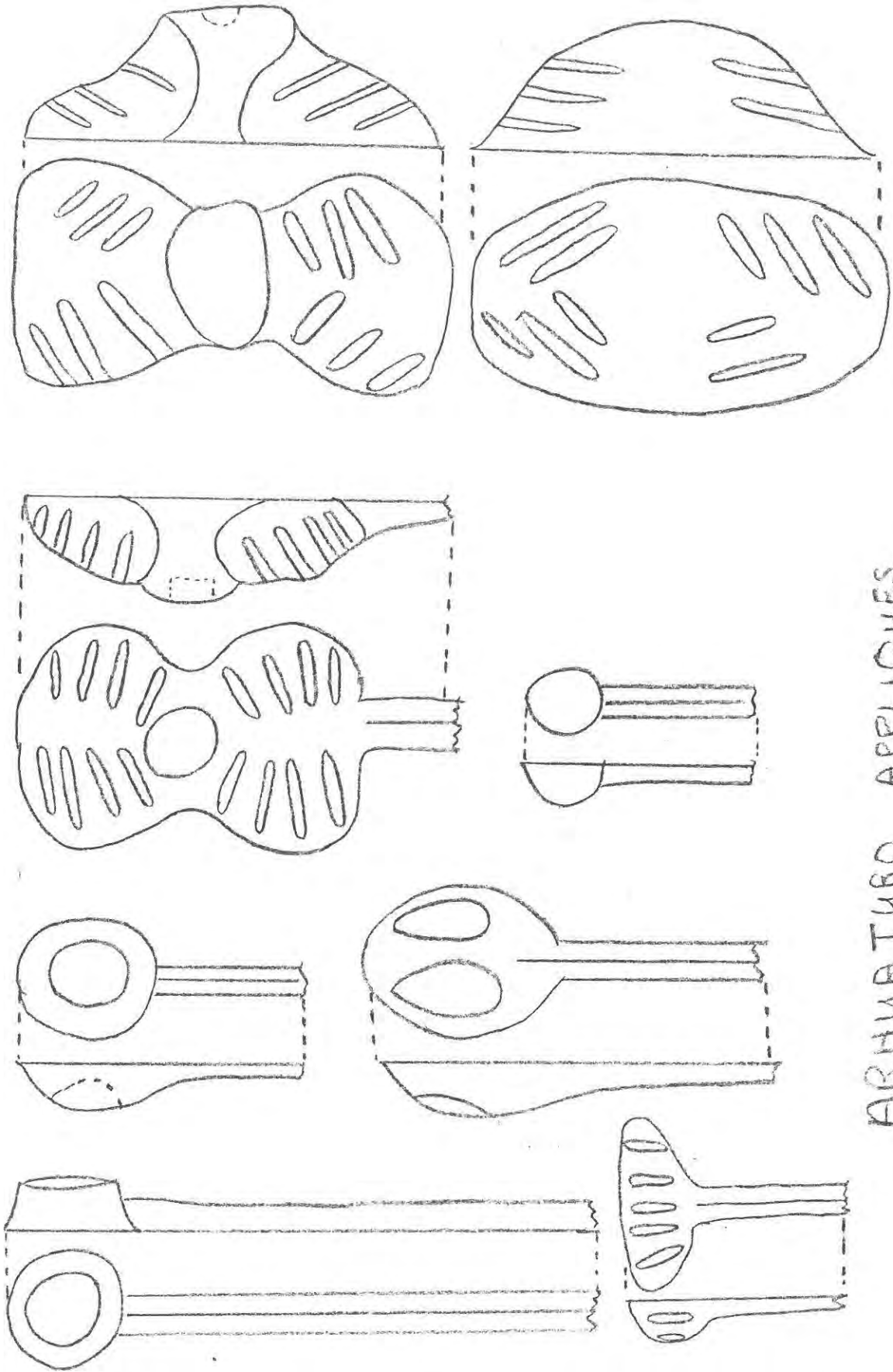
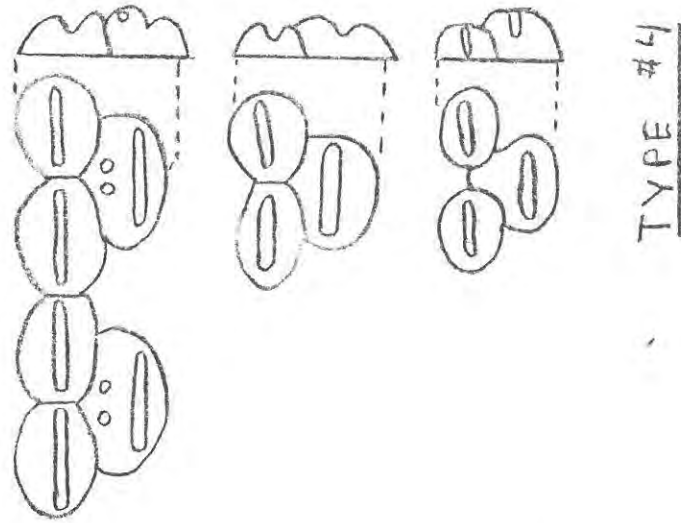

Fig. 168



ARHUA TURO APPLIQUES



TYPE #4

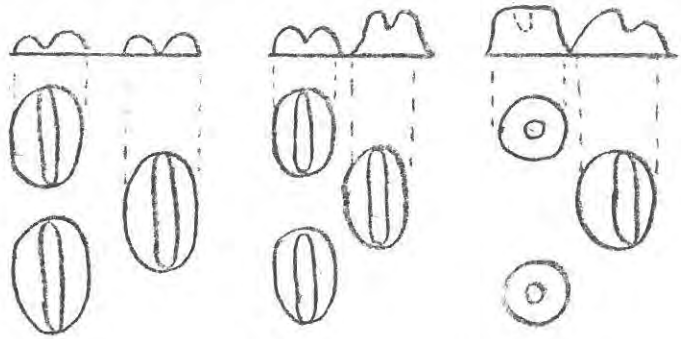

TYPE #5

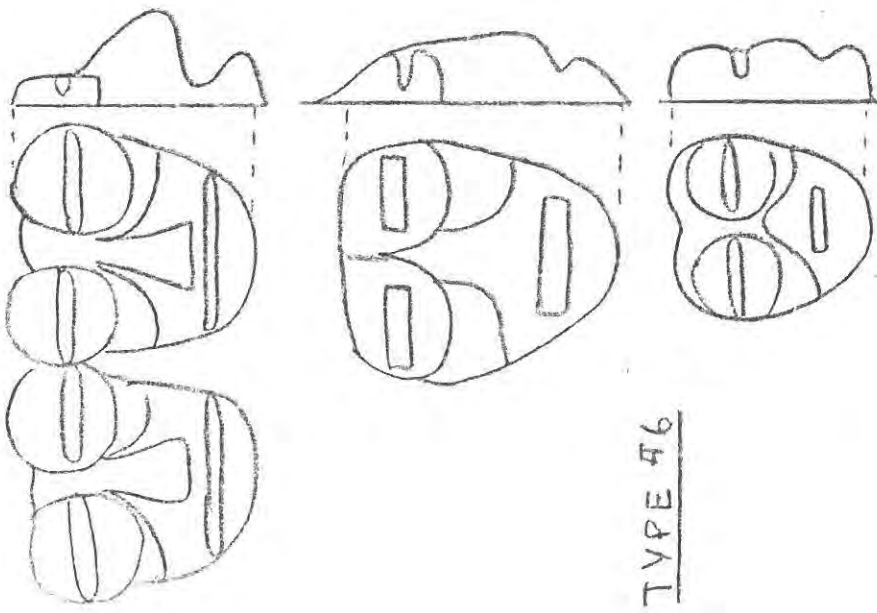

TYPE #6

ARHUATURO-INCA FACES

Fig. 170

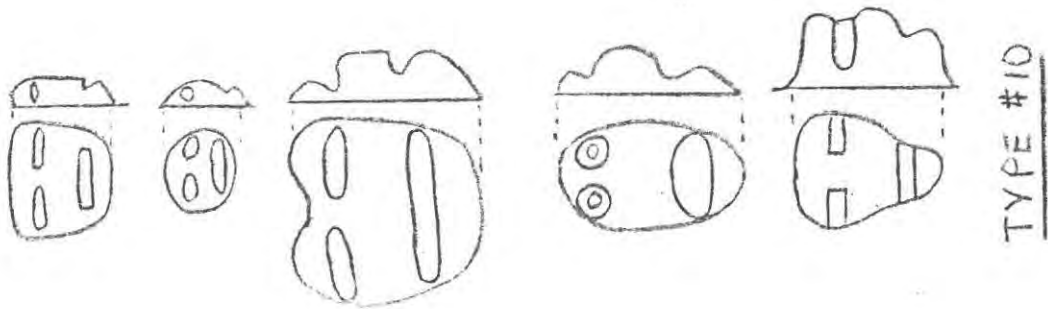
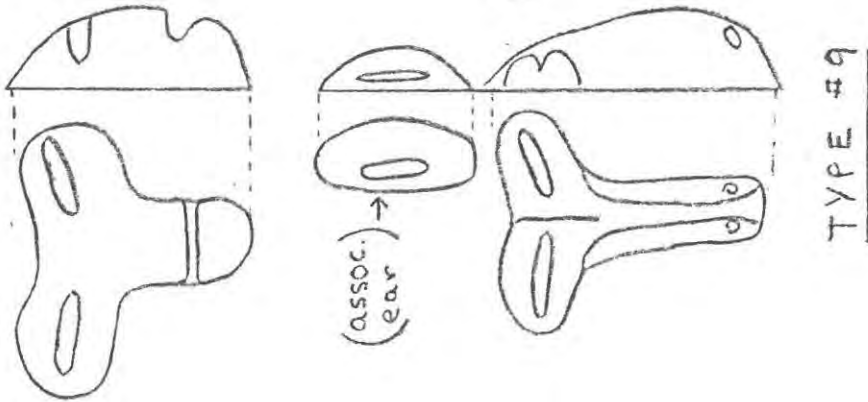
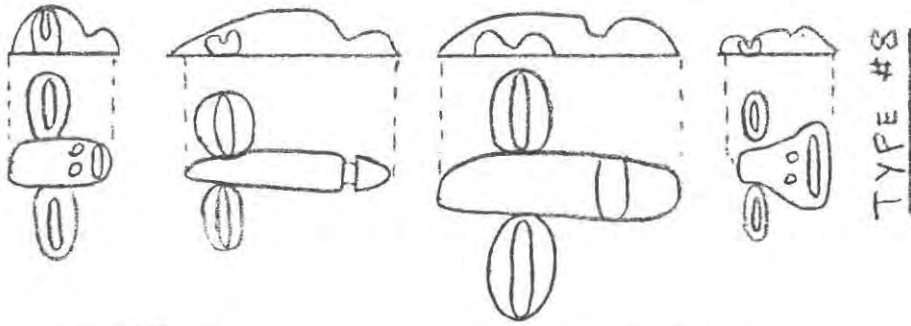
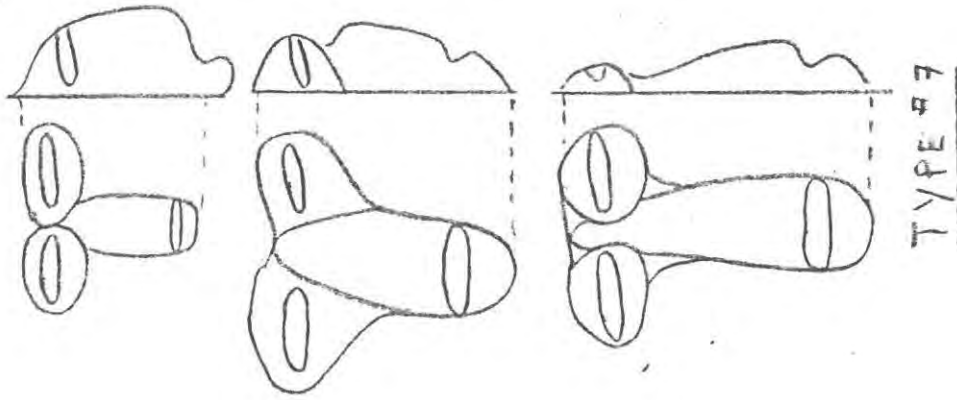

ARHUATURO - INCA FACES

Fig. 171

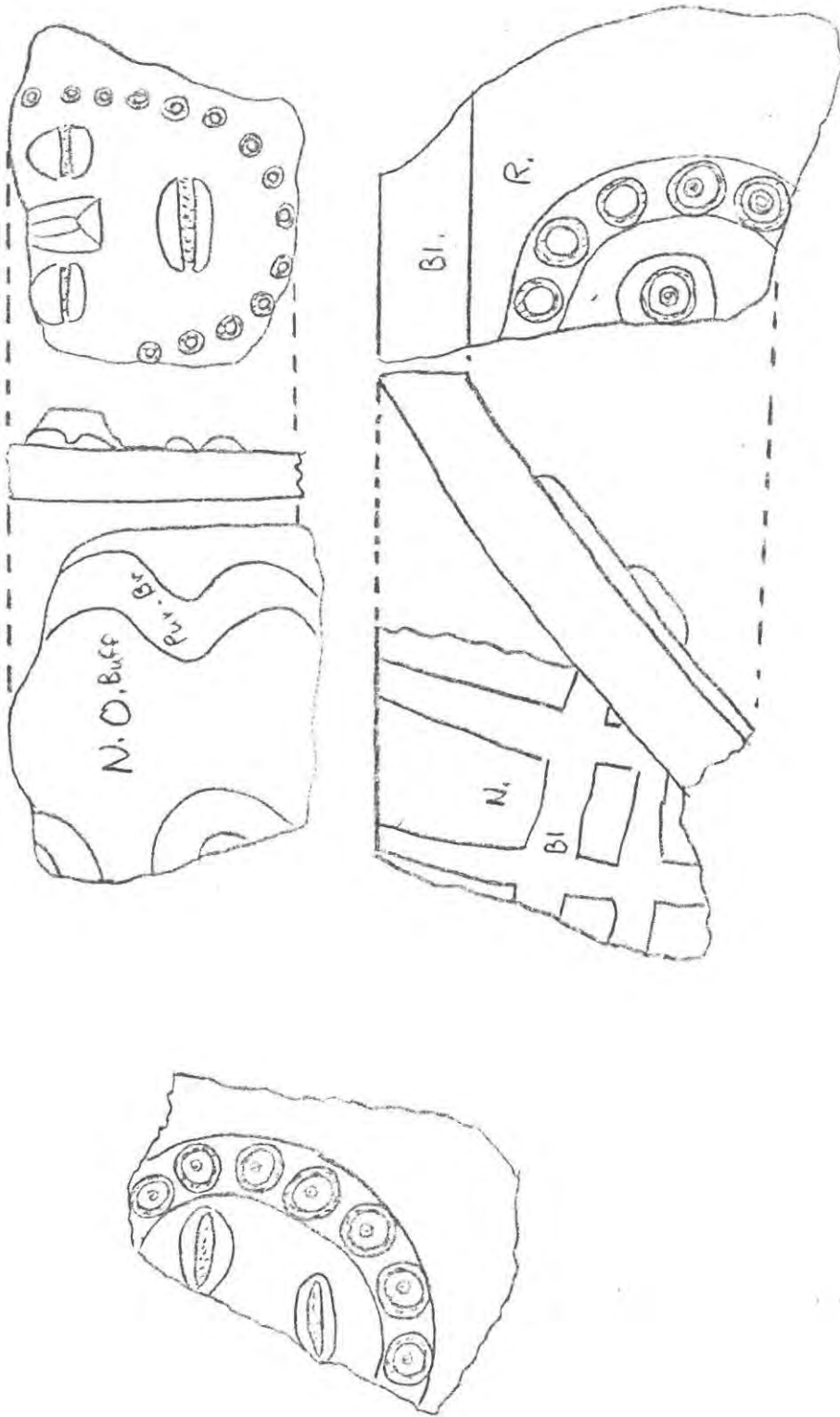

ARHUATURO? ARHUATURO - INCA? VIQUES?

Fig. 172

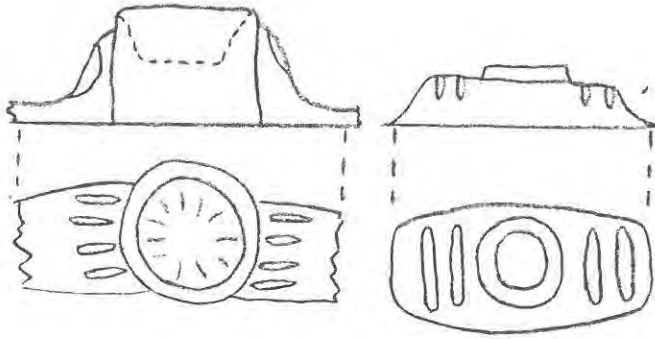
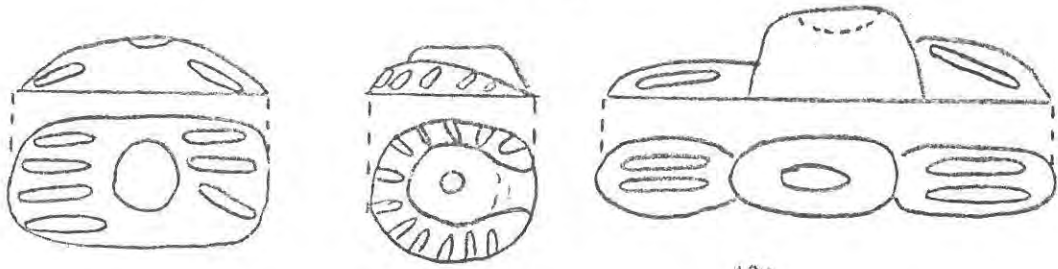

VARIOUS ABSTRACTS



ARHUATURO-INCA APPLIQUES

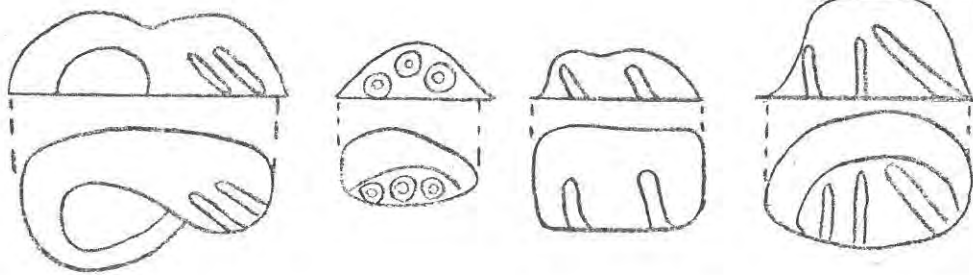

STANDARD EARS

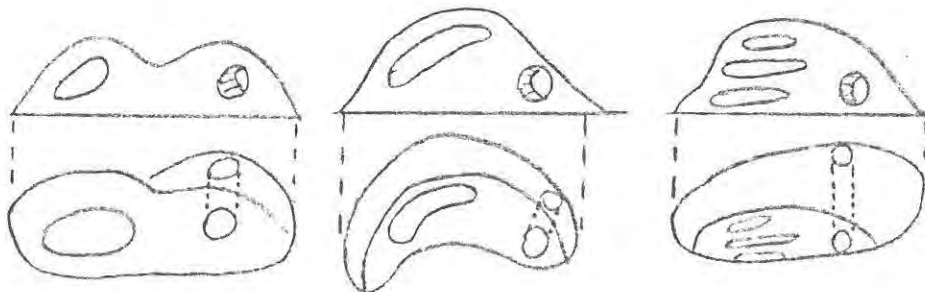

DRILLED EARS

Fig. 173

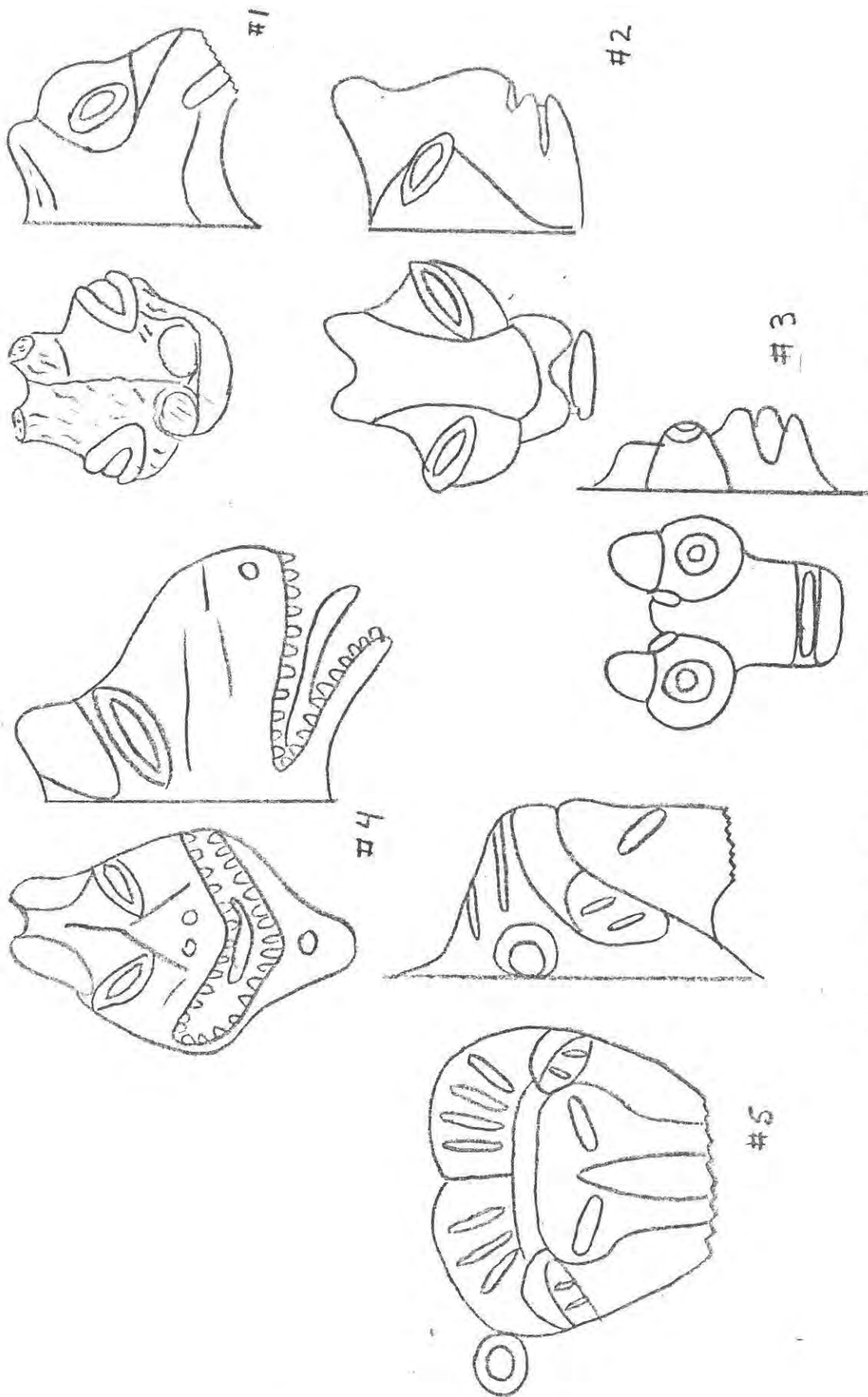

ARHUATURO - INCA ANIMAL HEADS

Fig. 175

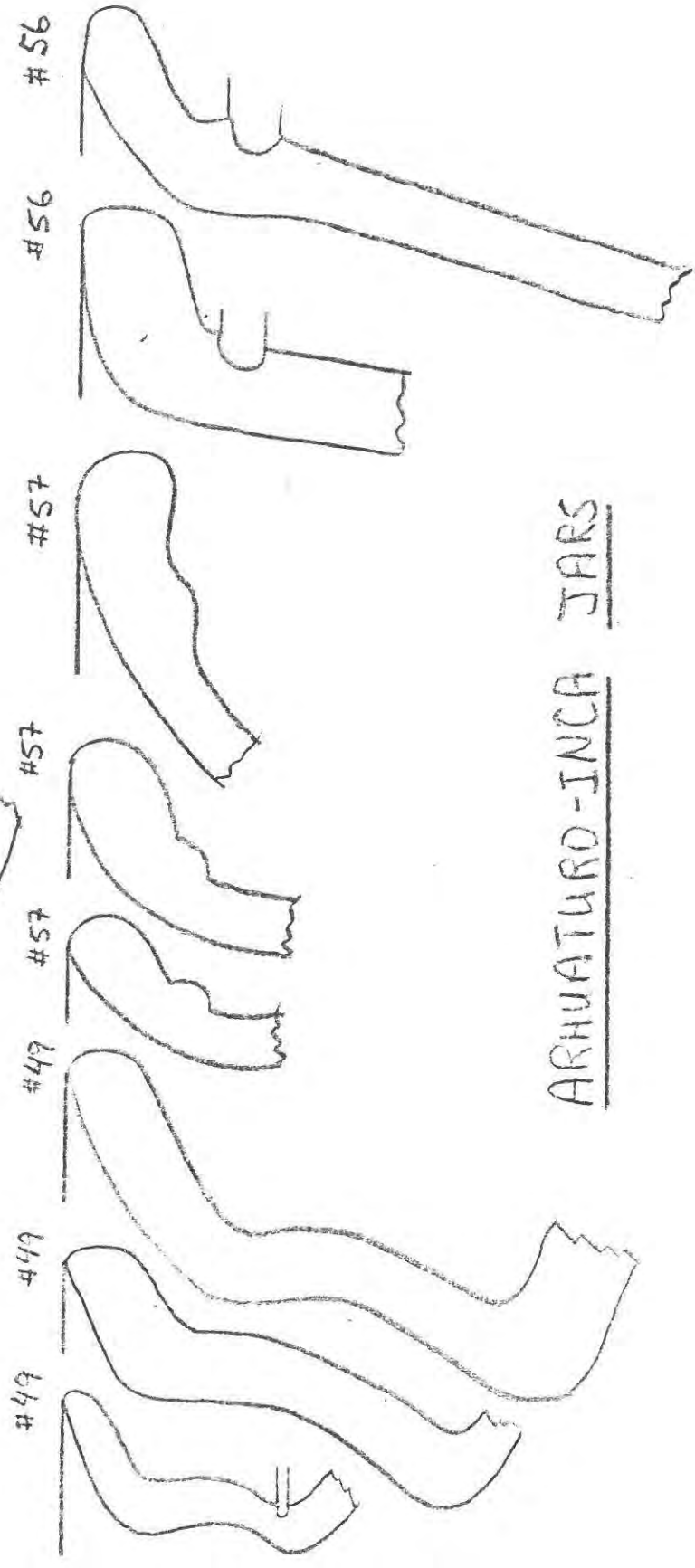
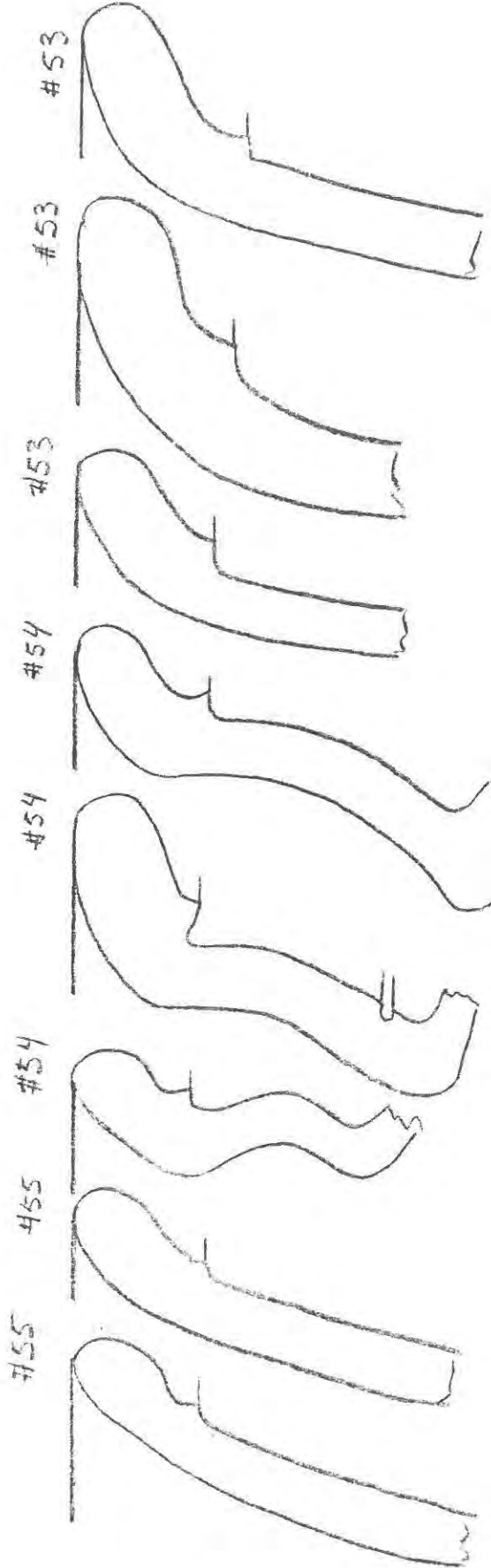

ARHUATURO-INCA JARS

Fig. 176

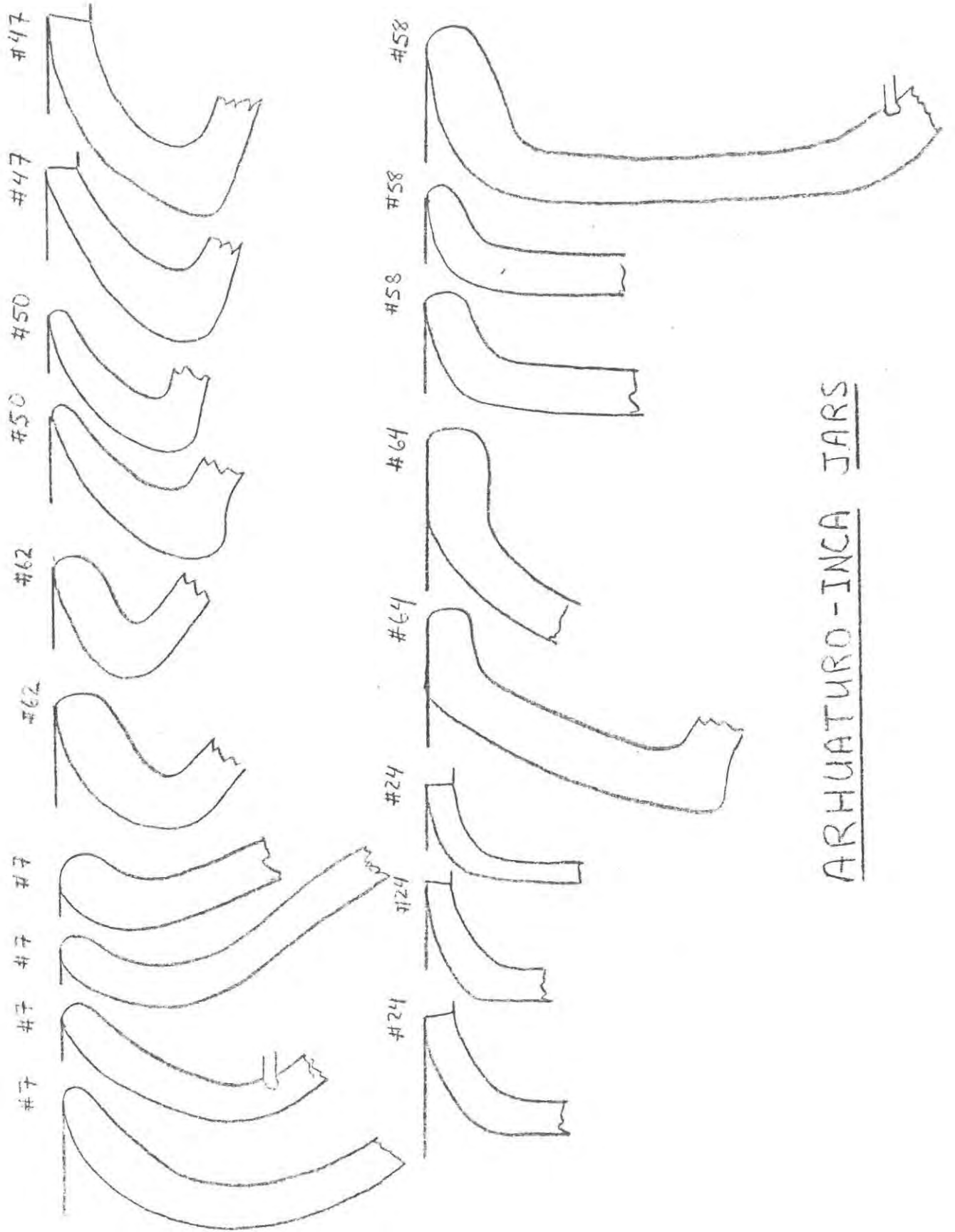

ARHUATURO-INCA JARS

Fig. 177

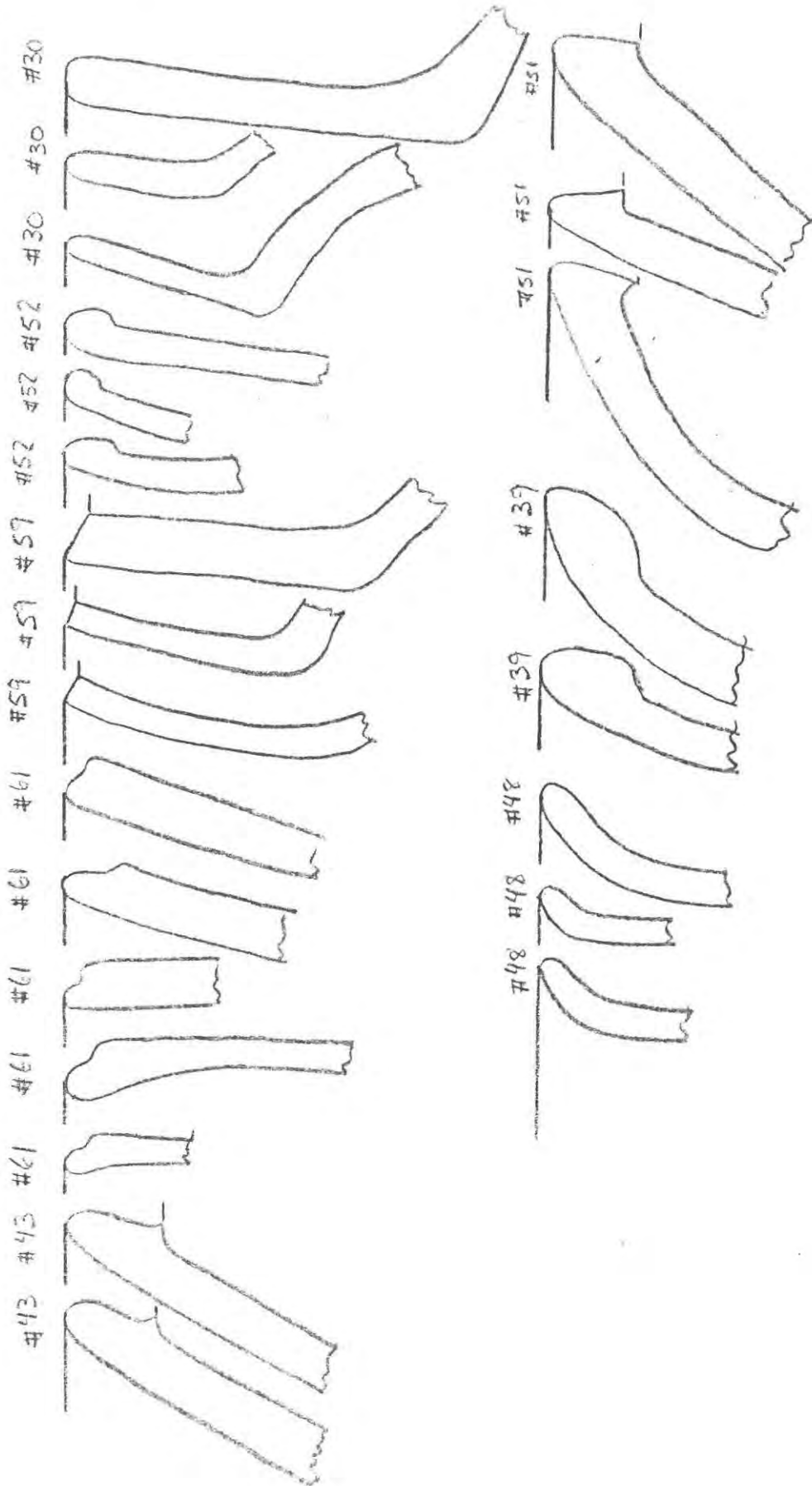

ARHUATURO-INCA JARS

Fig. 178

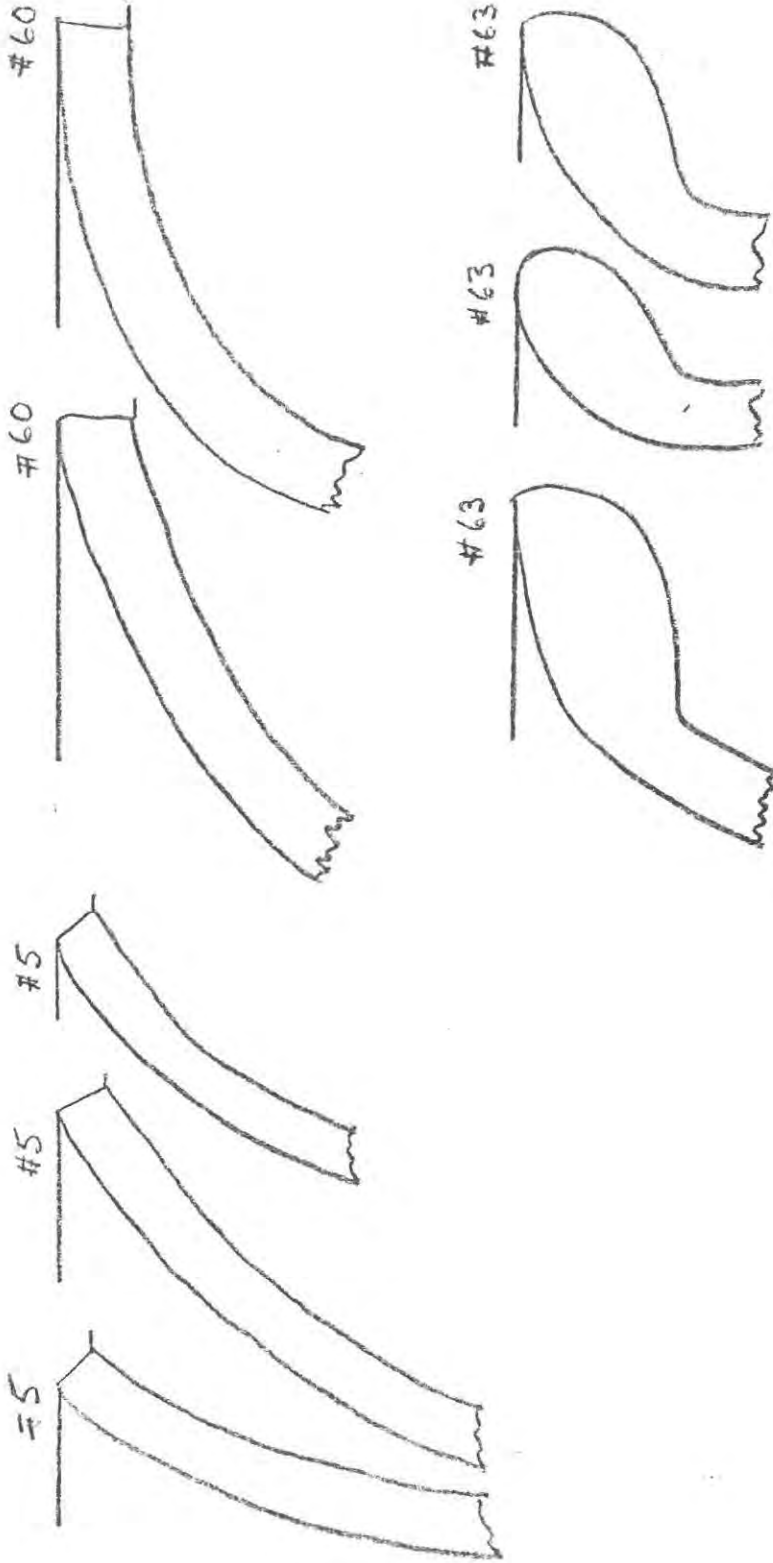

ARHUATURO-INCA JARS

Fig. 179

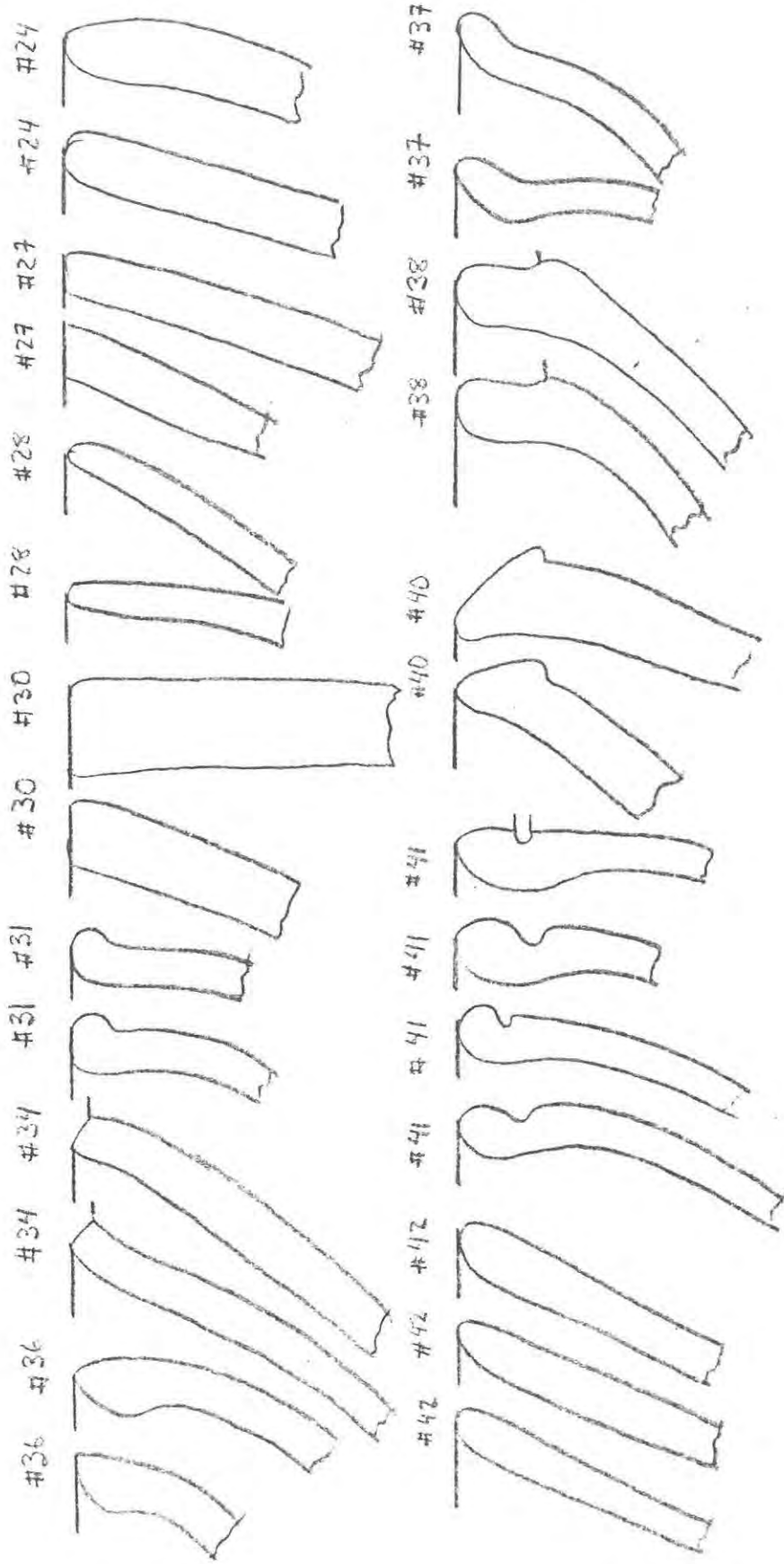

ARHUATURO-INCA OPEN BOWLS

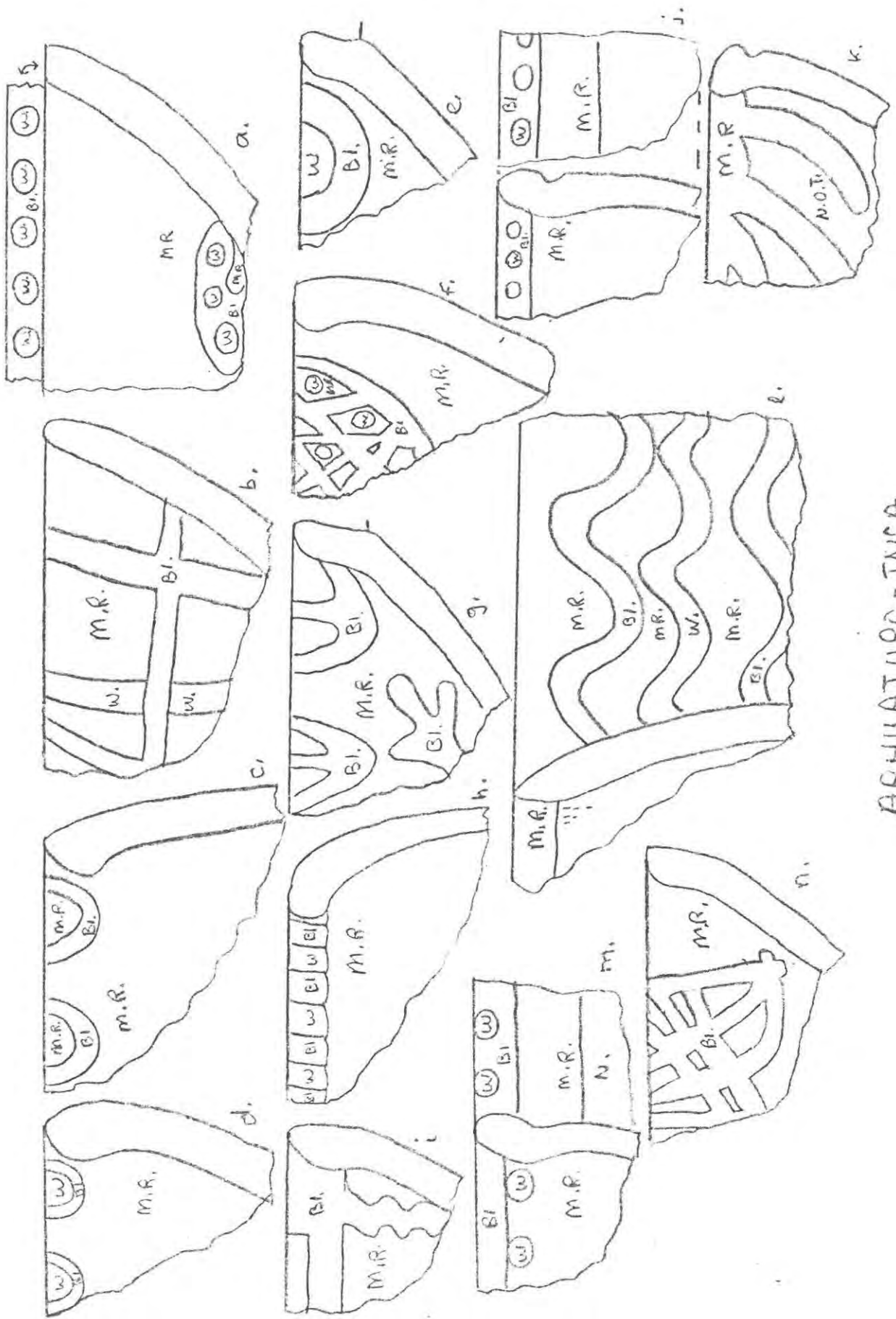

ARHUATURO-INCA

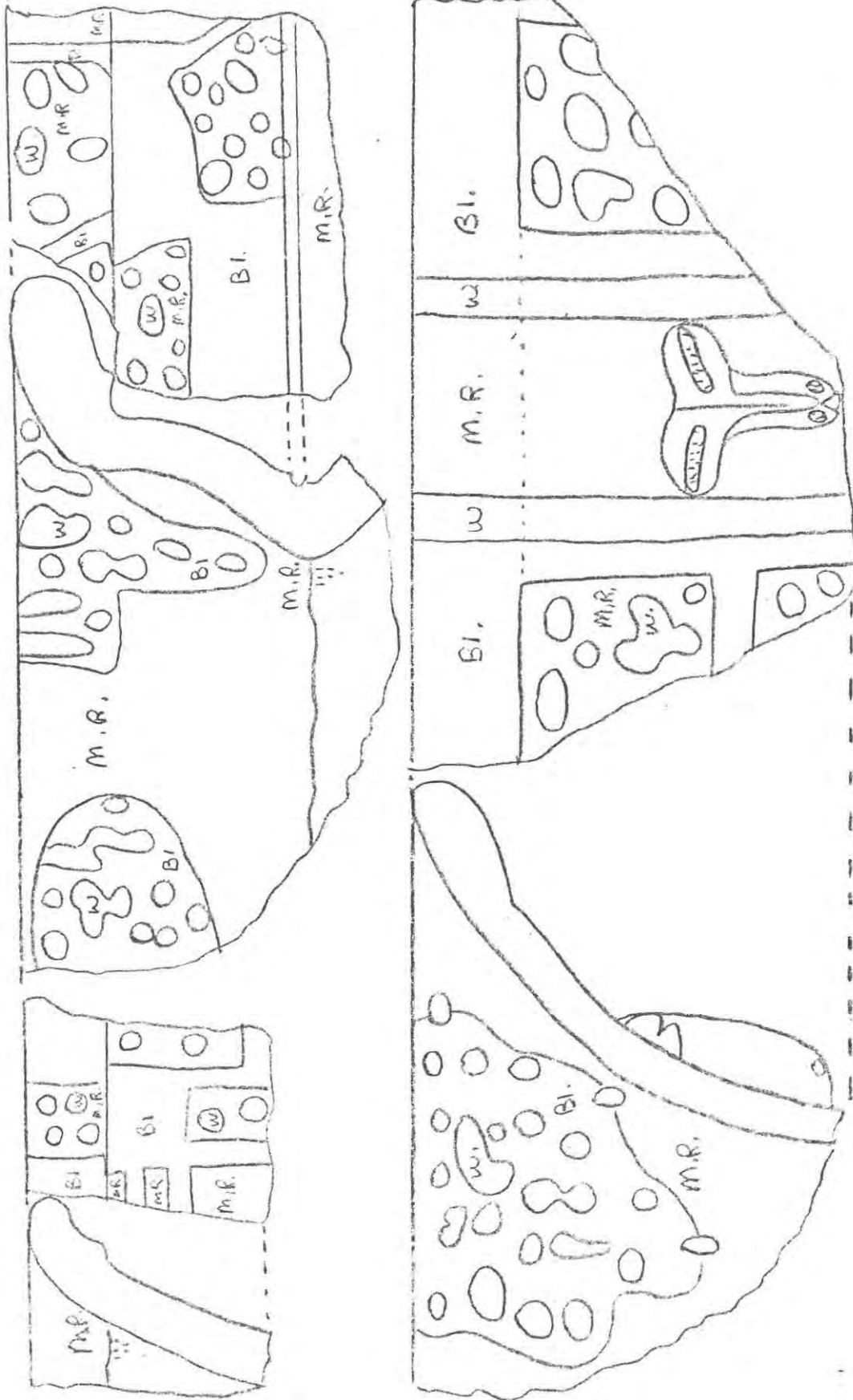

AKHWA TURO - INCA

Fig. 182

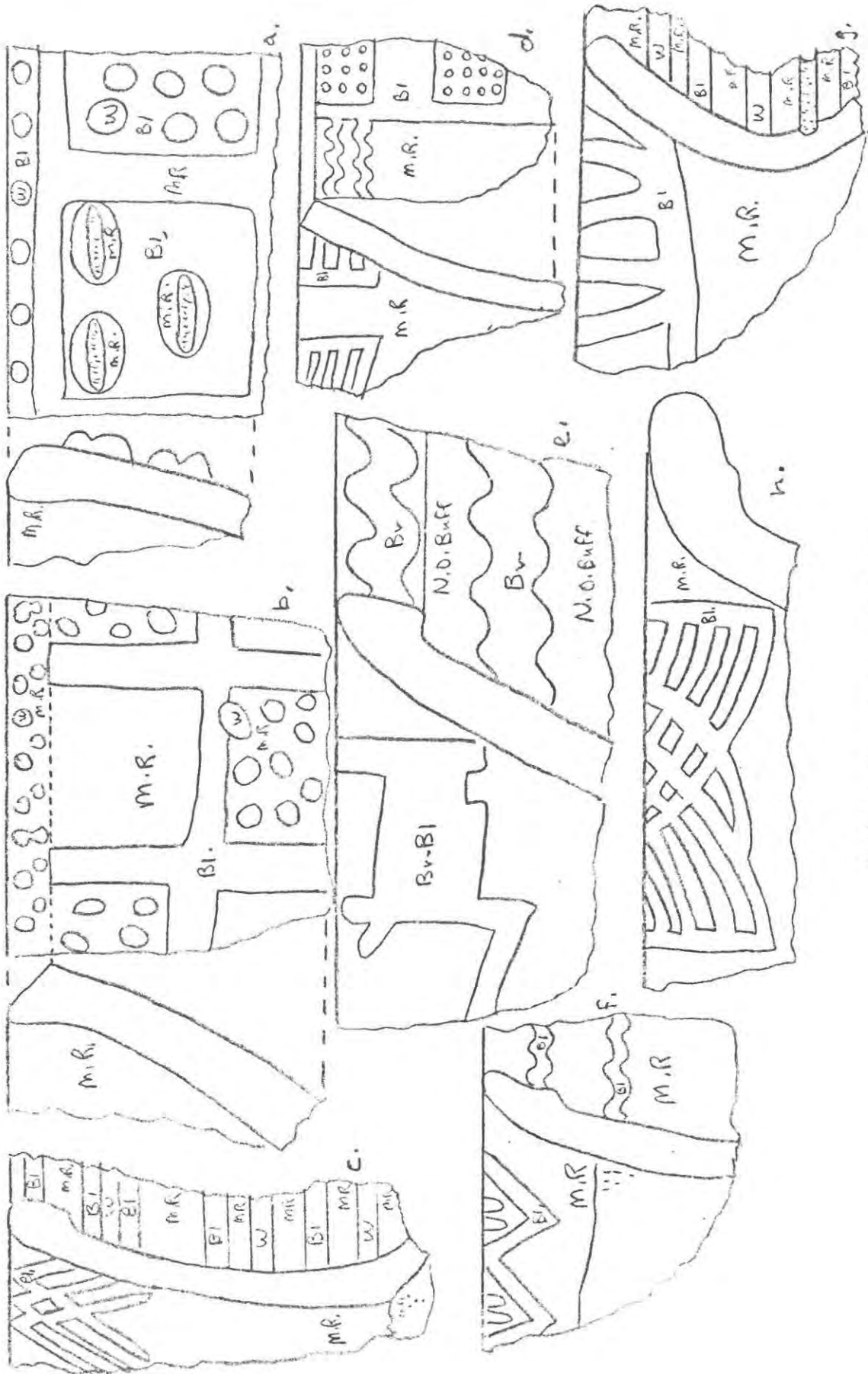

ARHUATURO-INCA

Fig. 183

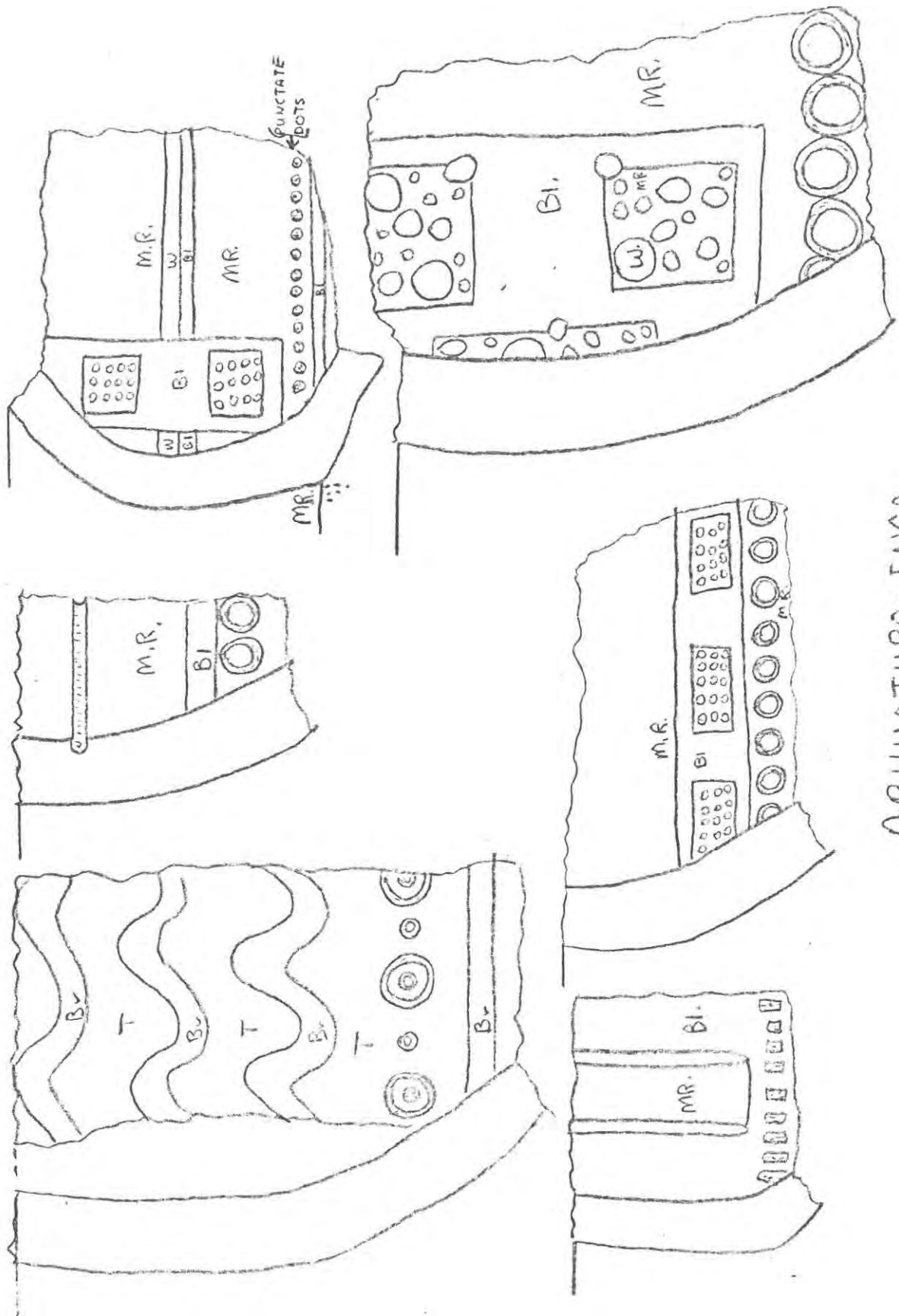

ARHUATURO-INCA

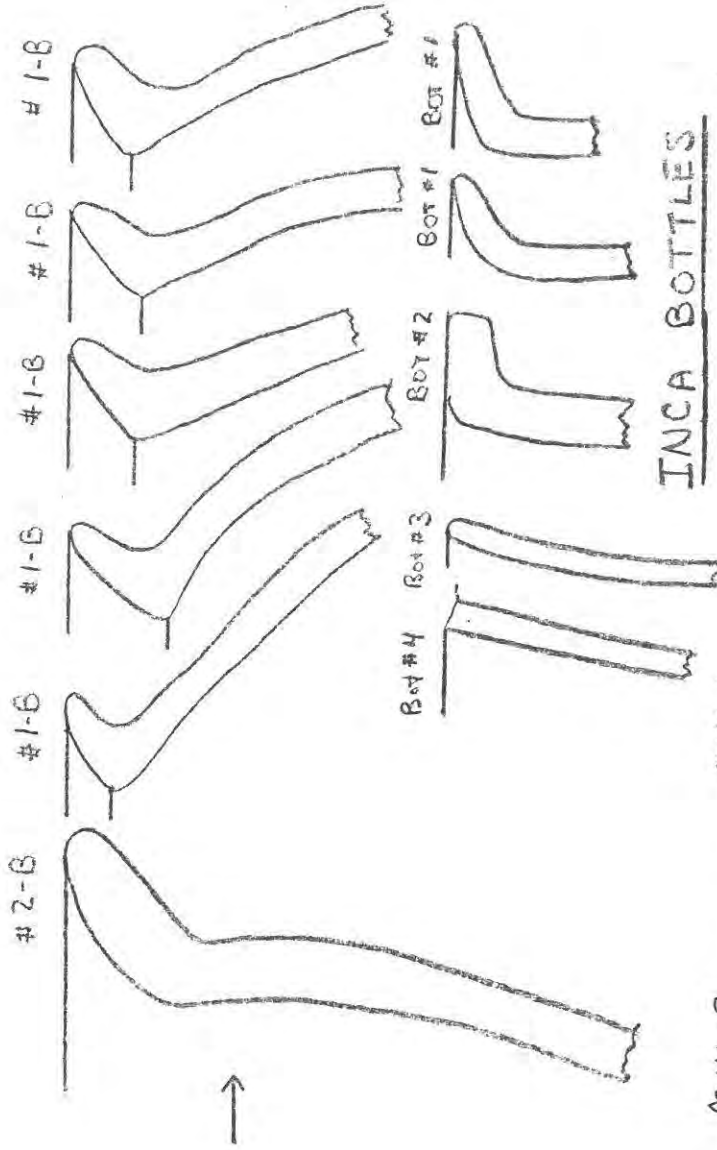

CHIMU-PACHACAMAC
BLACKWARE

INCA BOTTLES

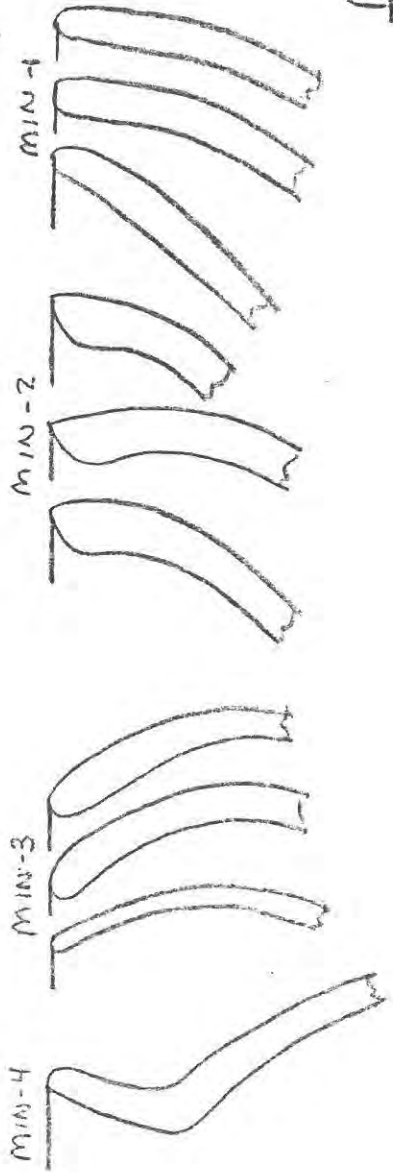

LOCAL INCA
MINIATURE WARE

INCA - VARIOUS

Fig. 185

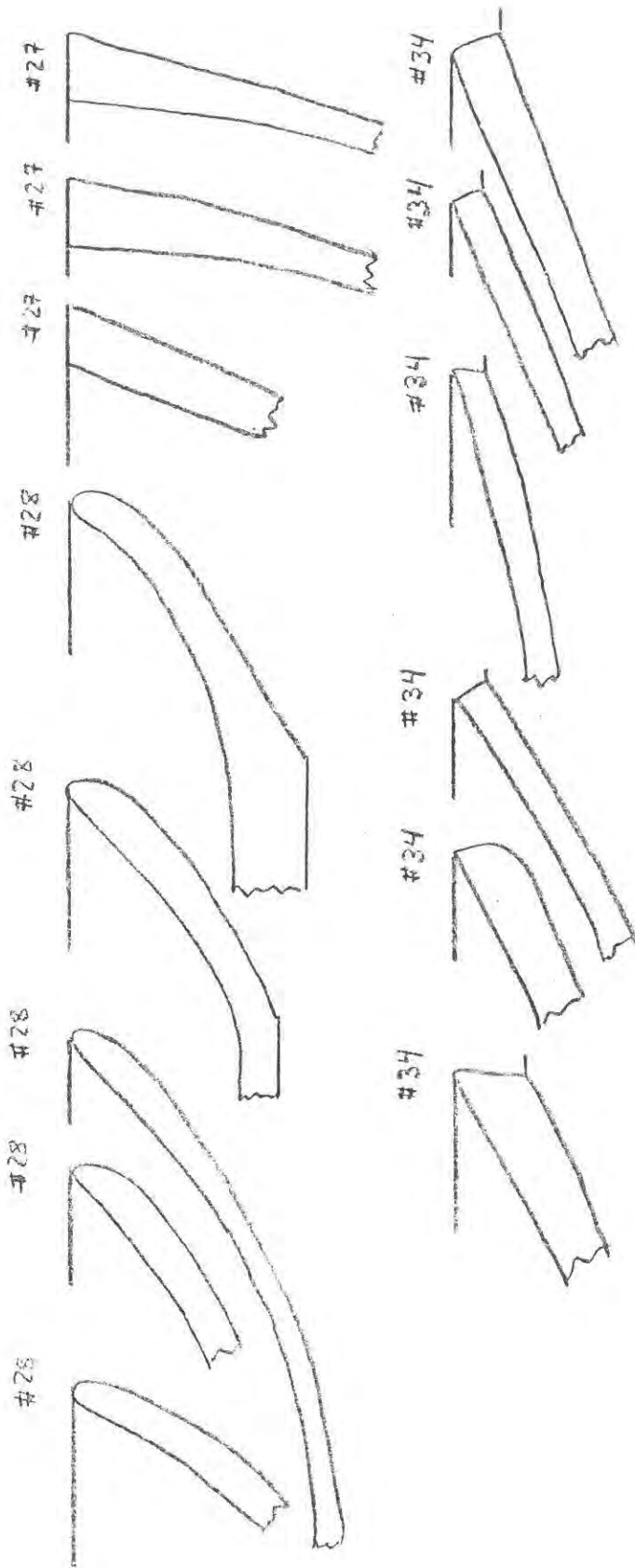

INCA - WARE #1 - BOWLS, PLATES

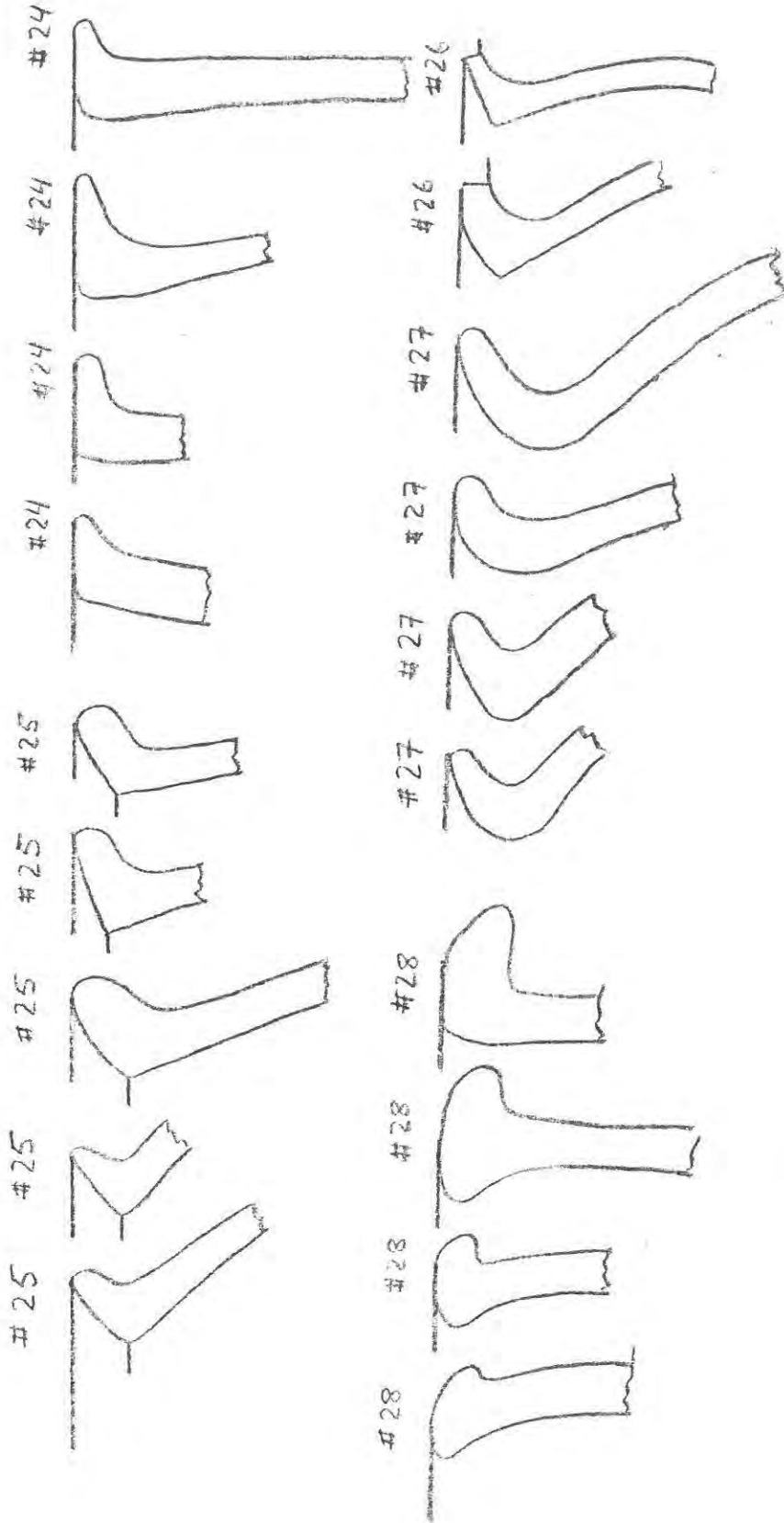

INCA - WARE #1 - RIMMED BOWLS

Fig. 187

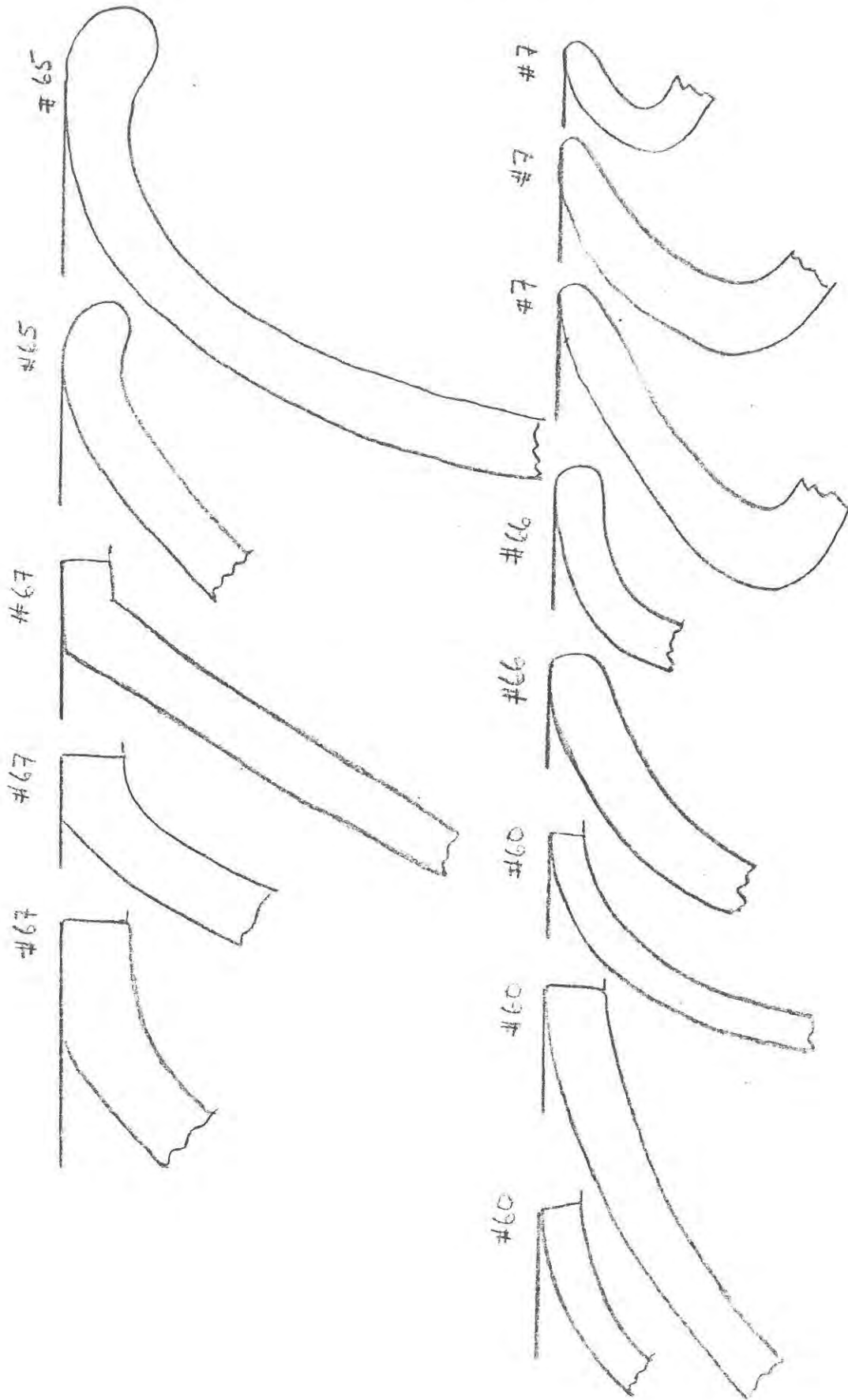

INCA - WARE #1 - JARS

Fig. 189

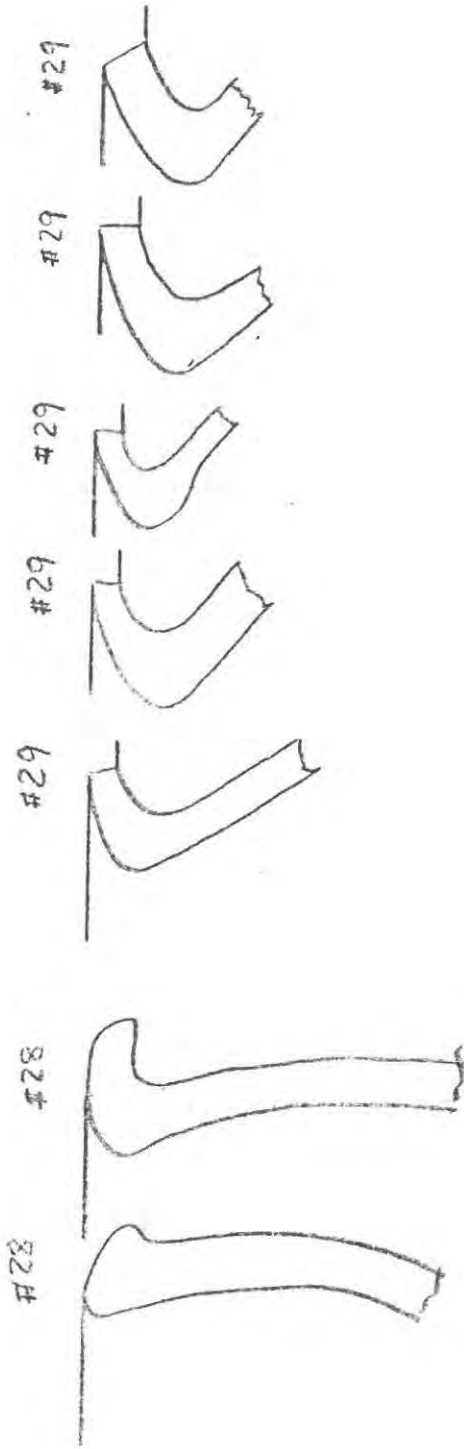
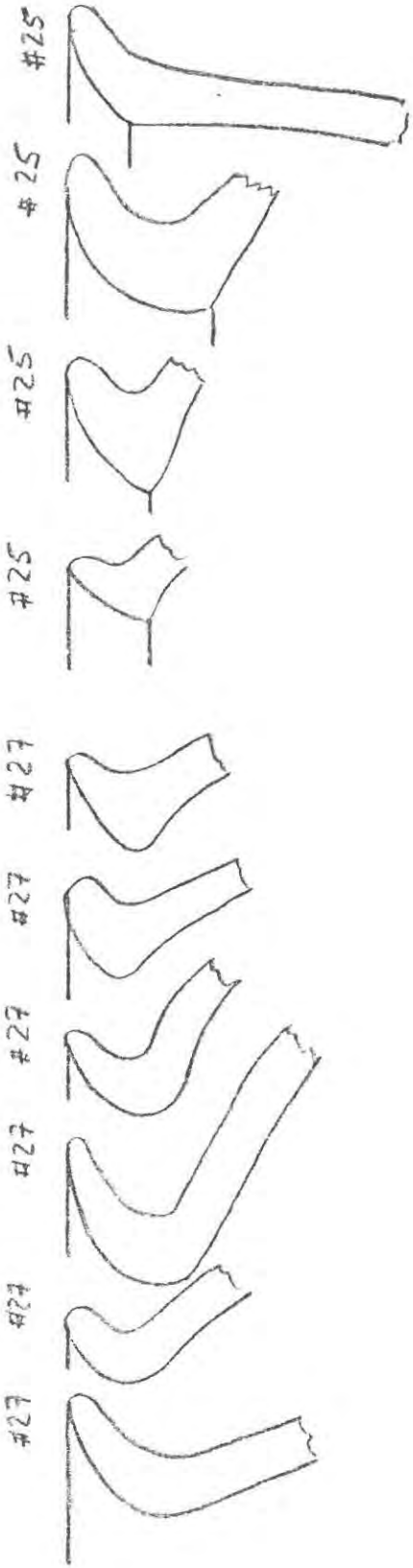

INCA - WARE # 2 - RIMMED BOWLS

Fig. 190

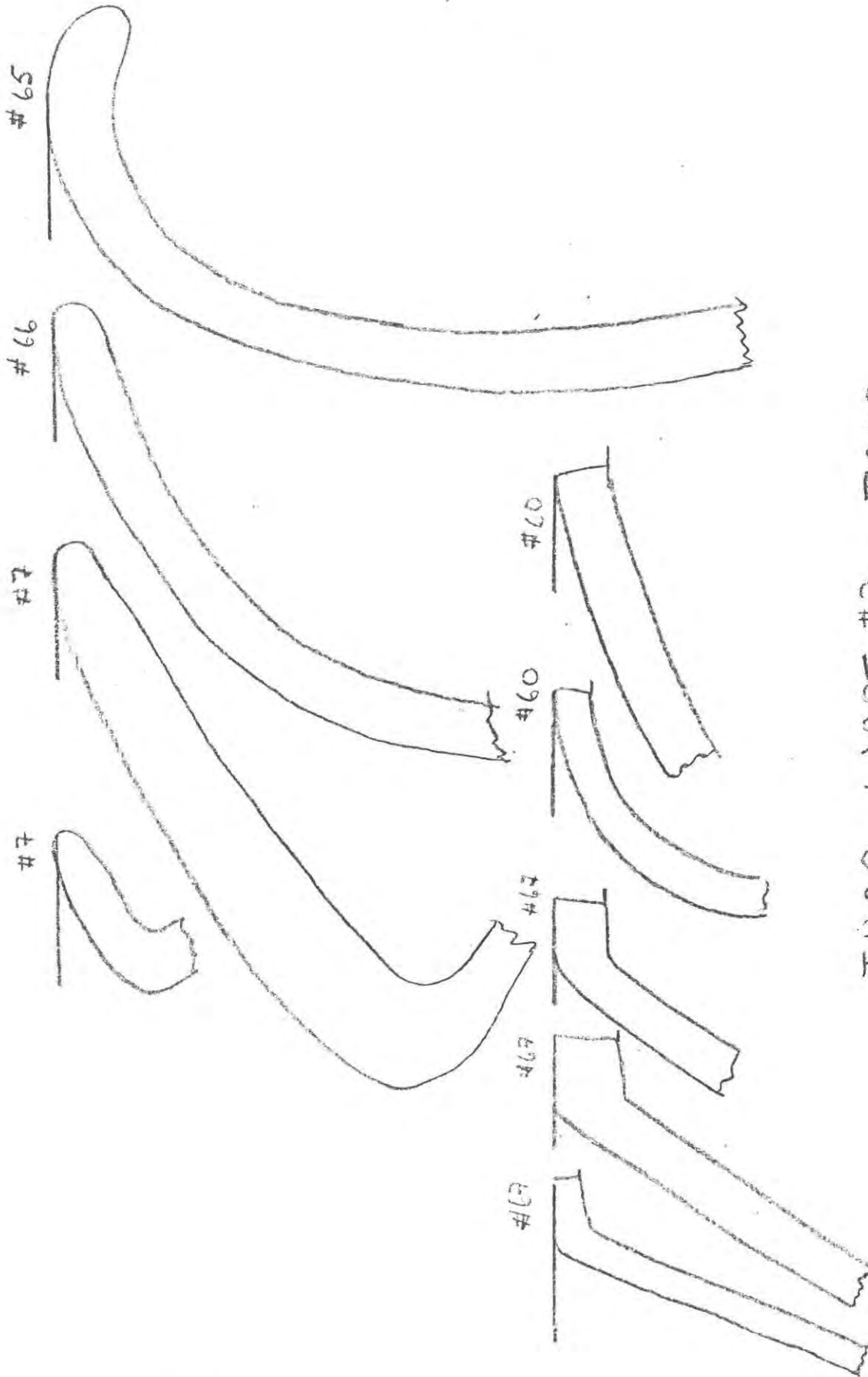

INCA-WARE #2 - JARS

Fig. 191

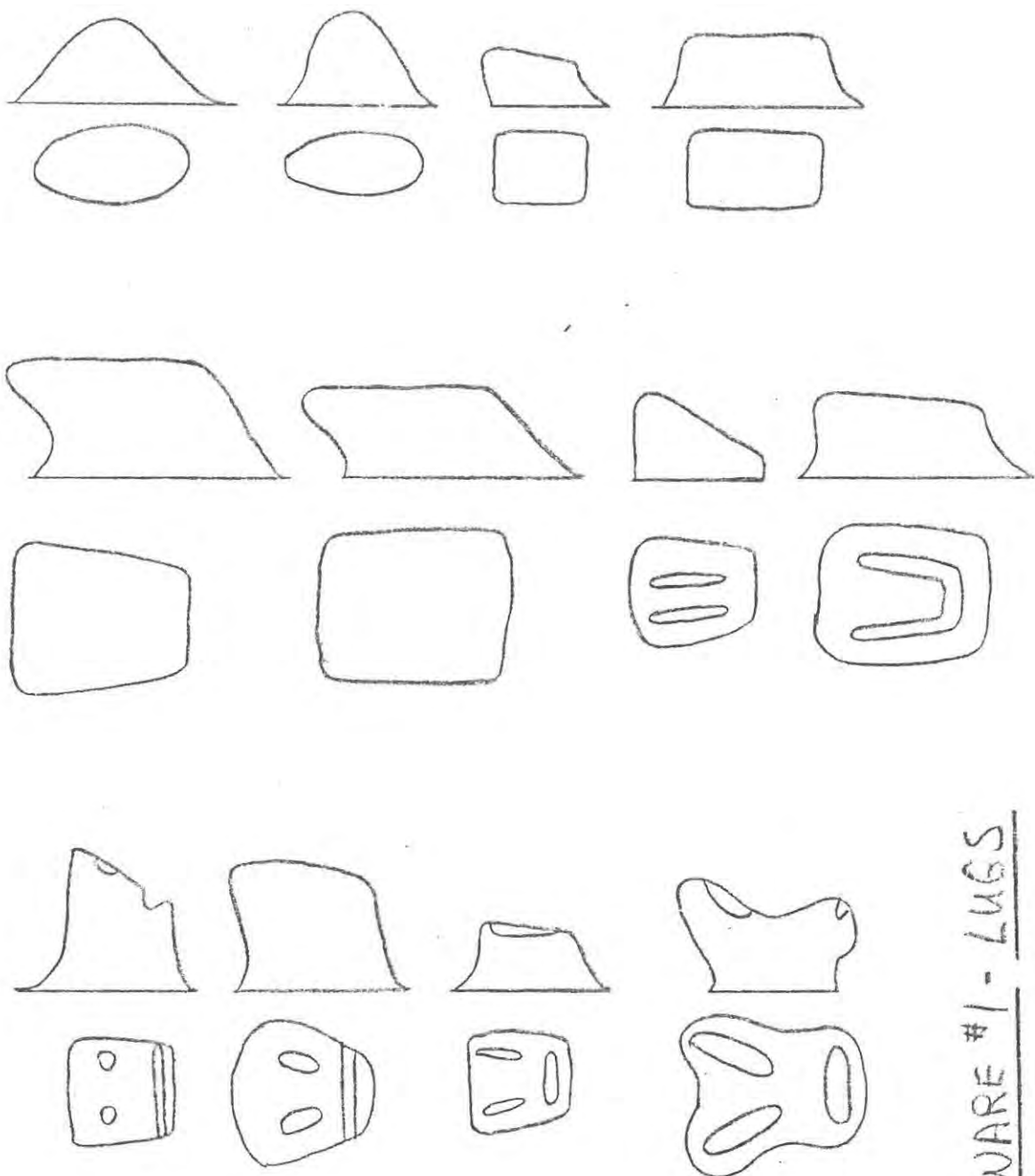

INCA-WARE #1 - LUGS

Fig. 192

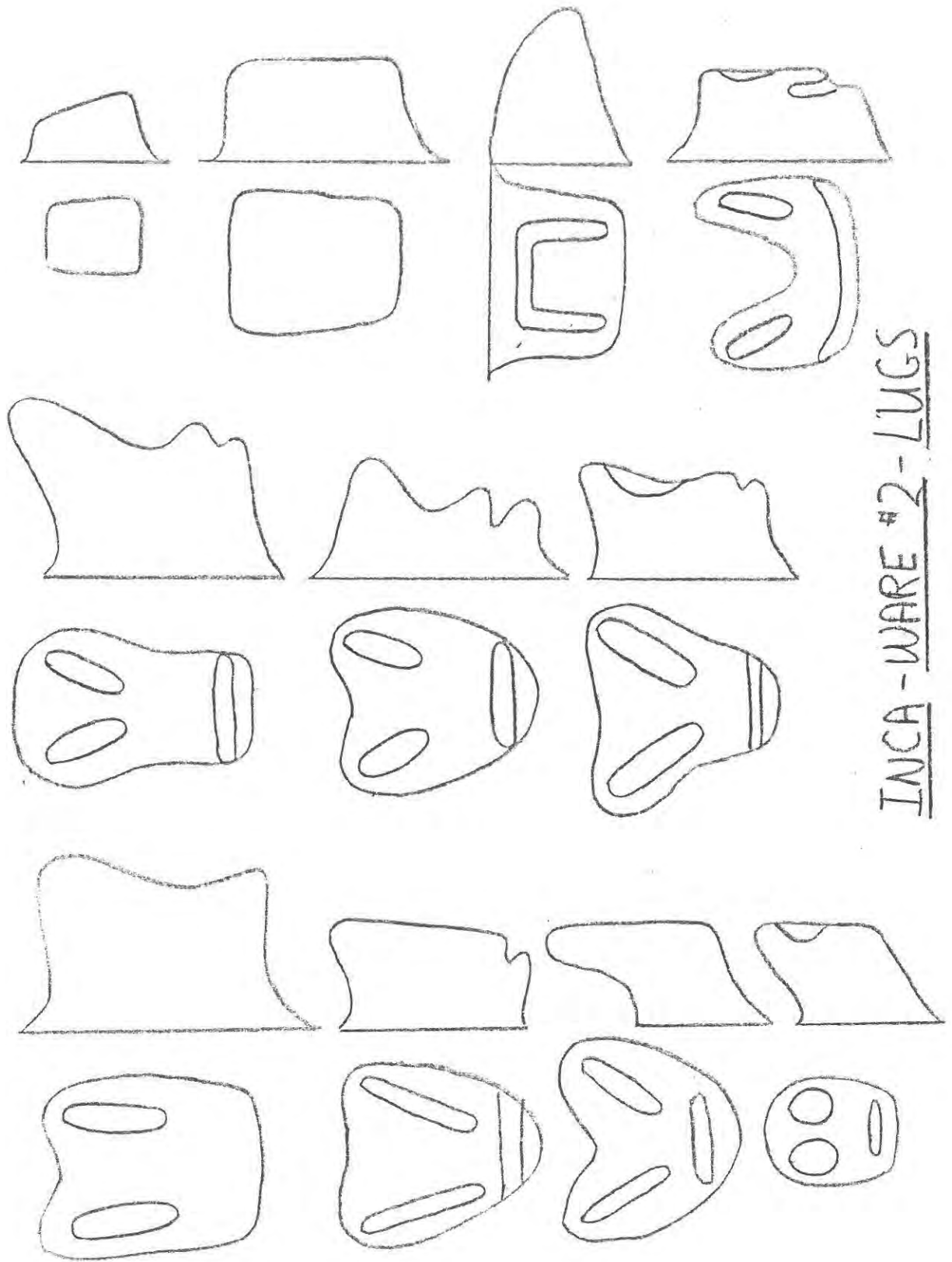

INCA-WARE #2-LUGS

Fig. 193

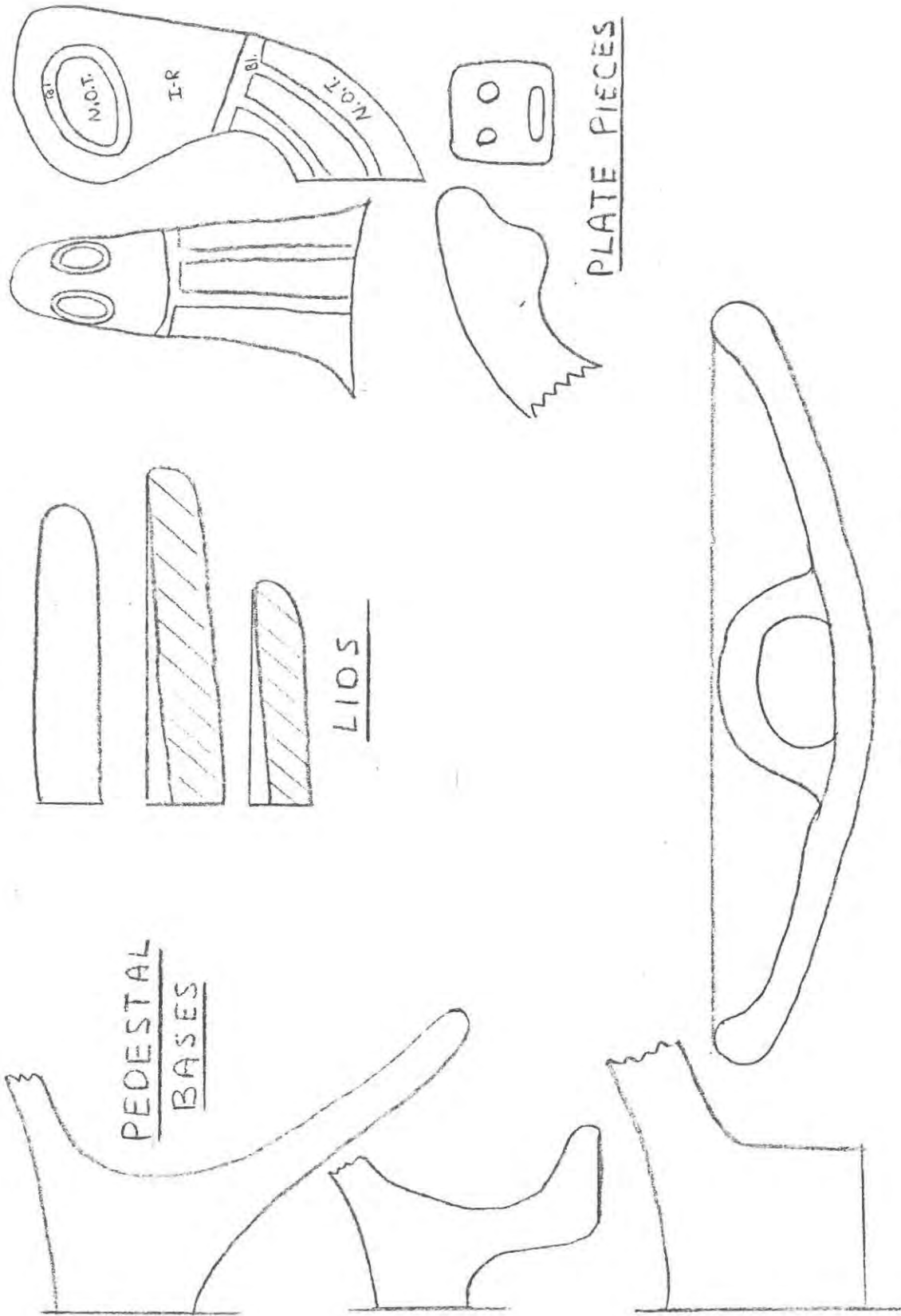

PEDESTAL
BASES

SOIL

PLATE PIECES

INCA - VARIOUS

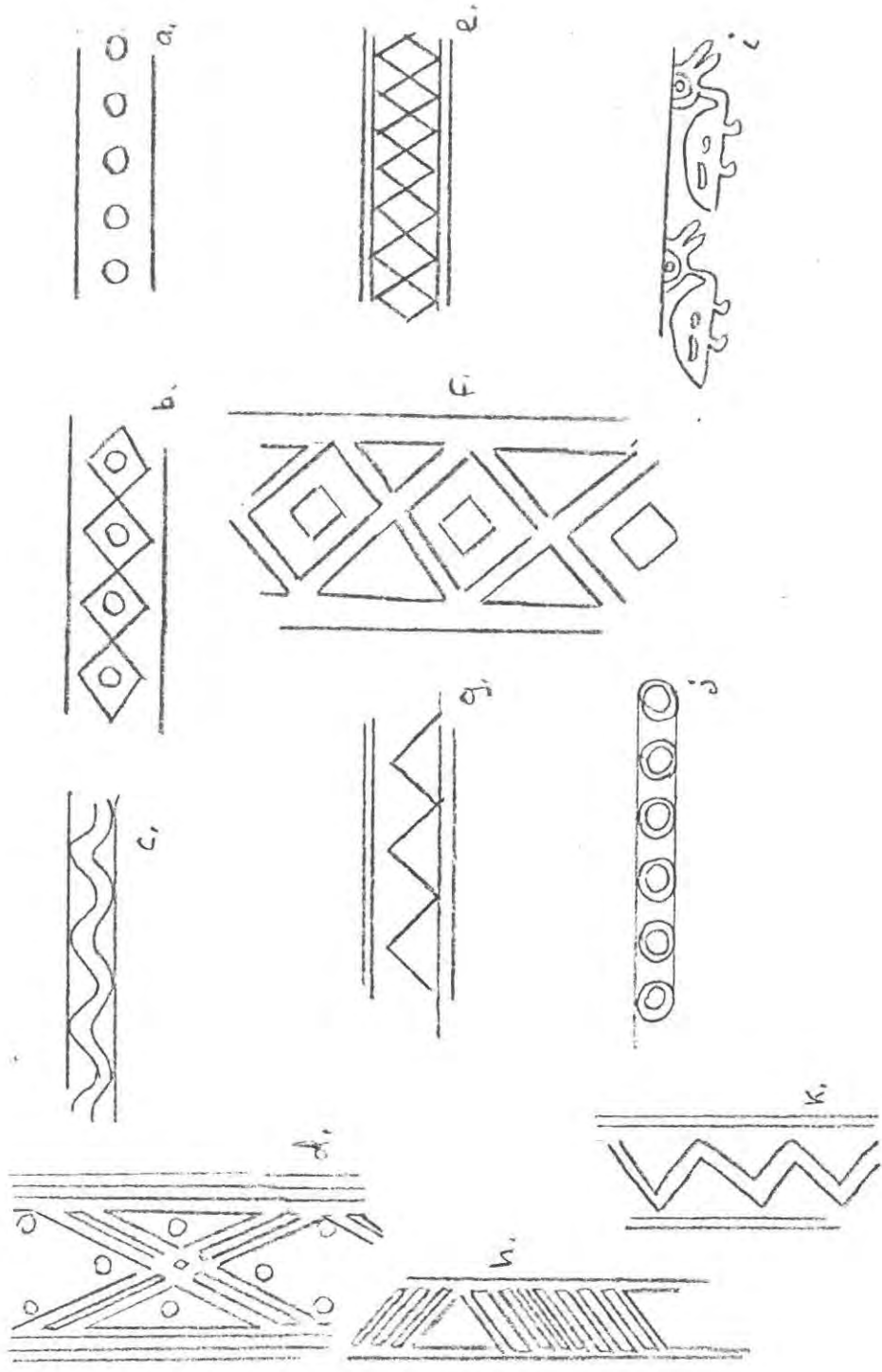

INCA WARE #1 TYPICAL MOTIFS

Fig. 195

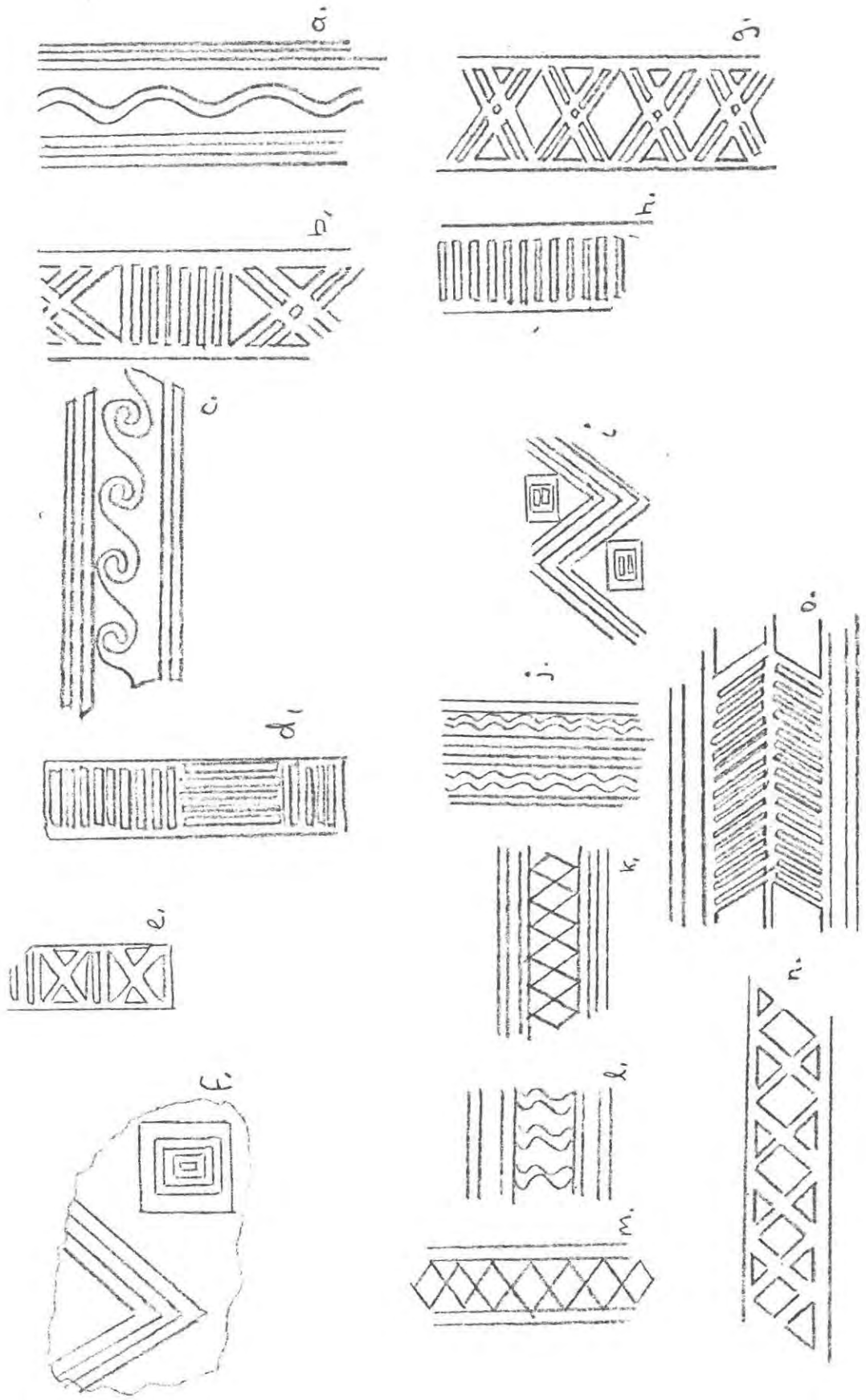

INCA WARE #2 TYPICAL MOTIFS

Fig. 196

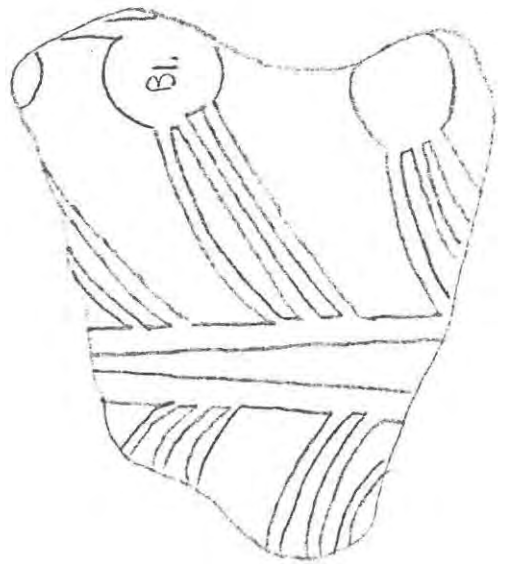
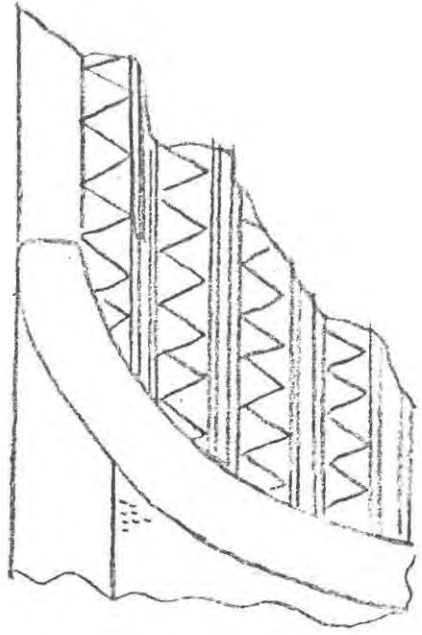
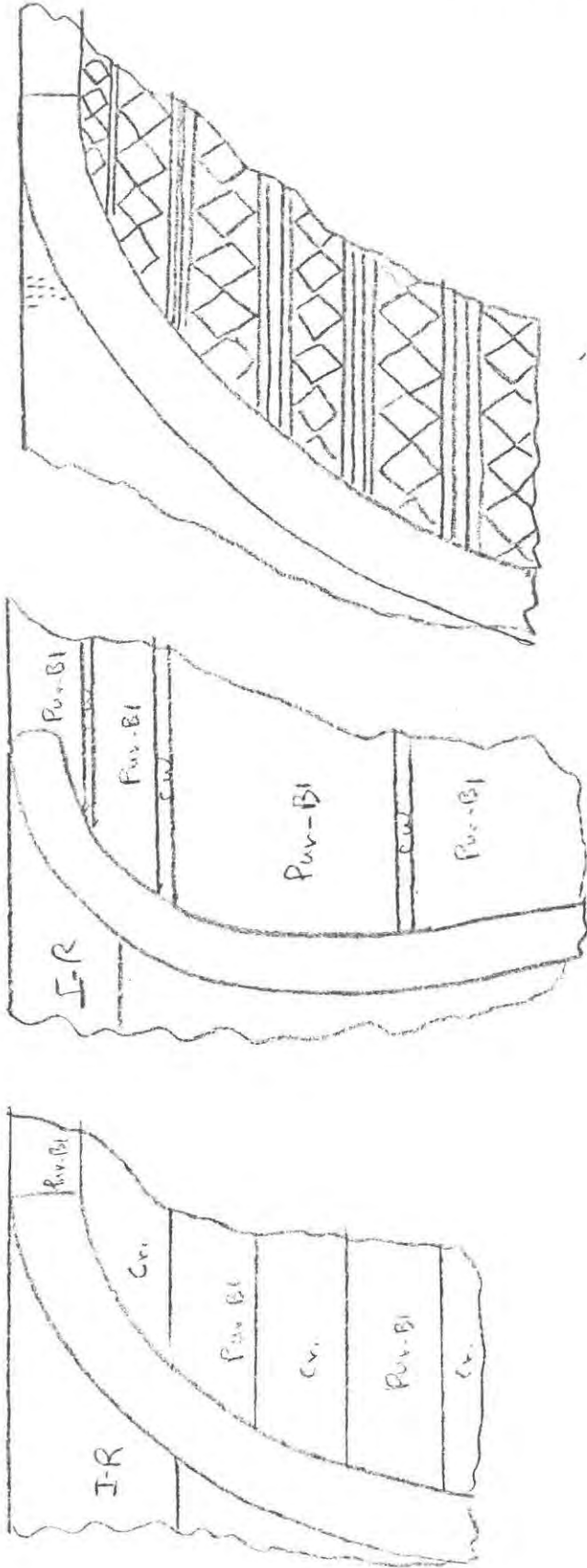

TYPICAL INCA - BOTH WARES

Fig. 197

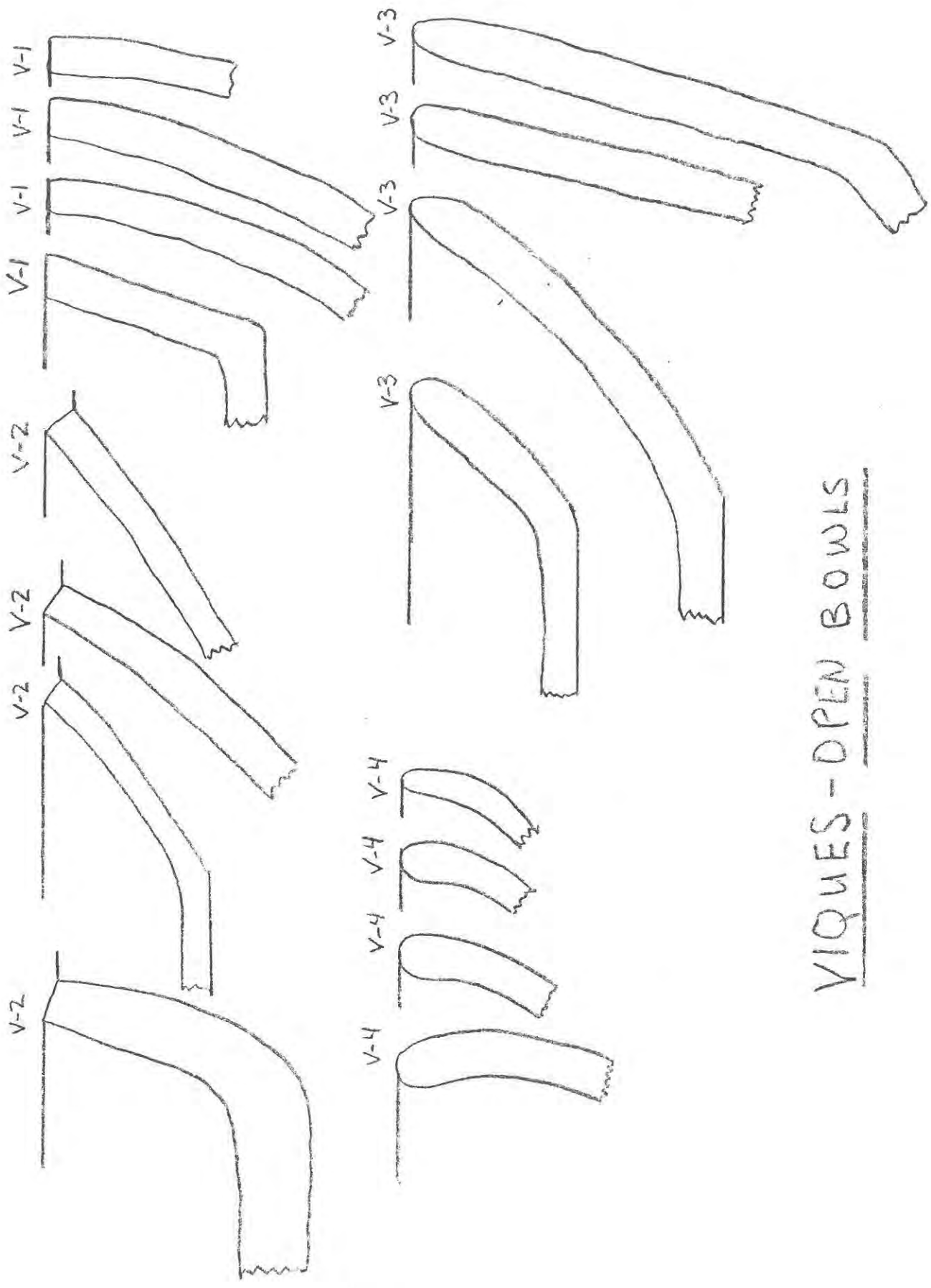

VIQUES - OPEN BOWLS

Fig. 198

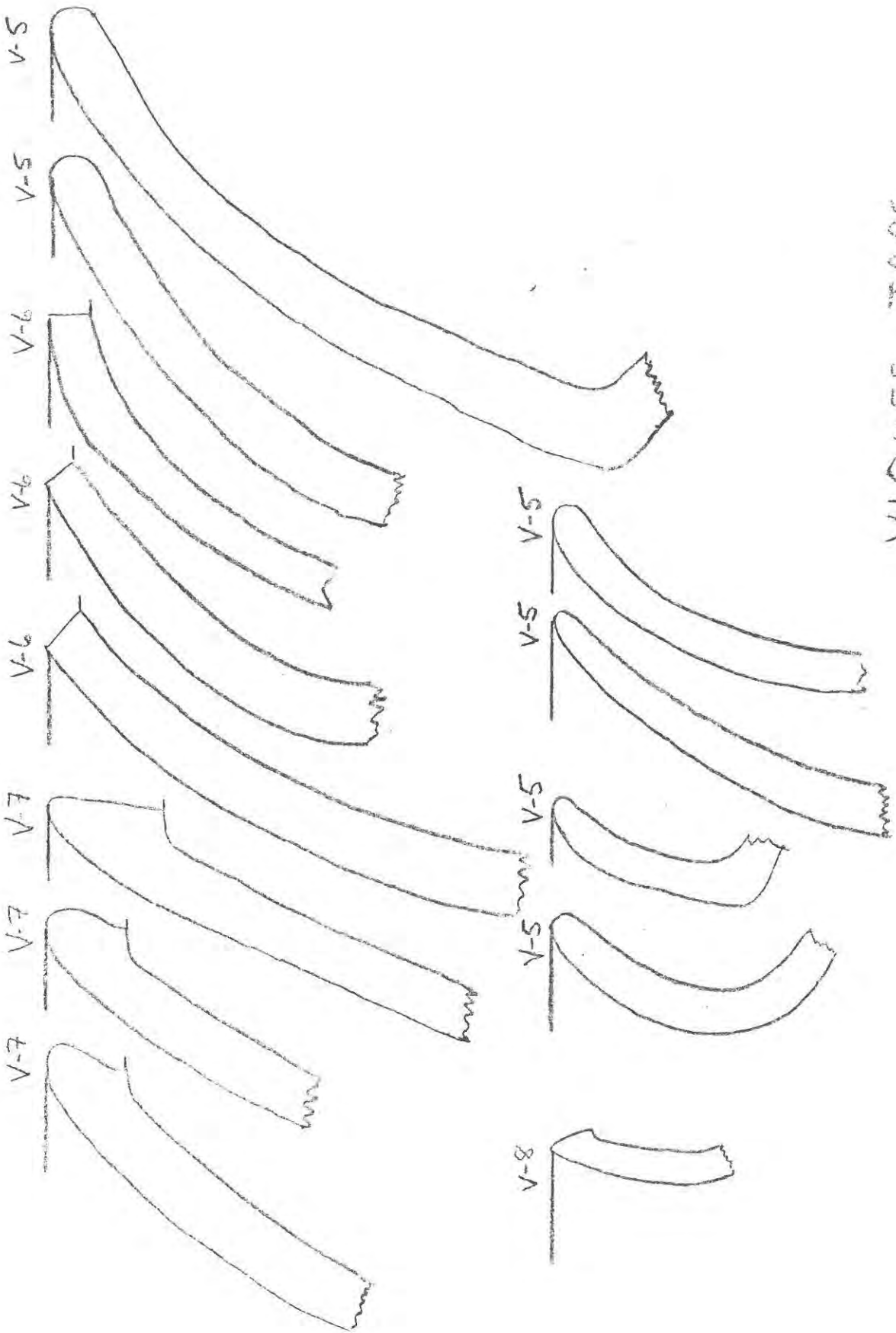

VIQUES JARS

Fig. 199

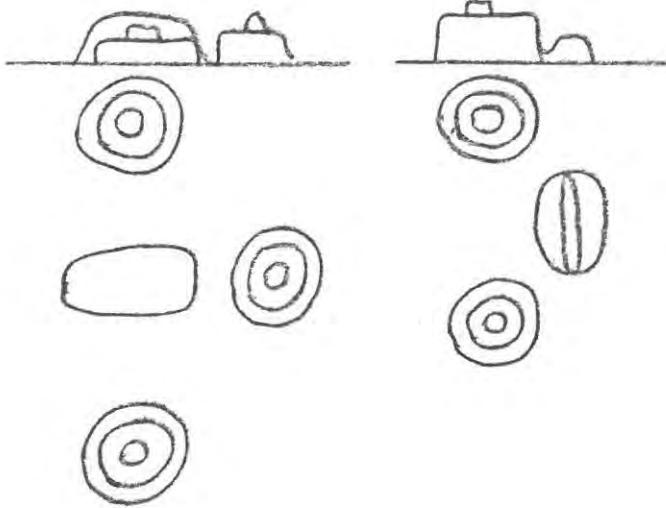
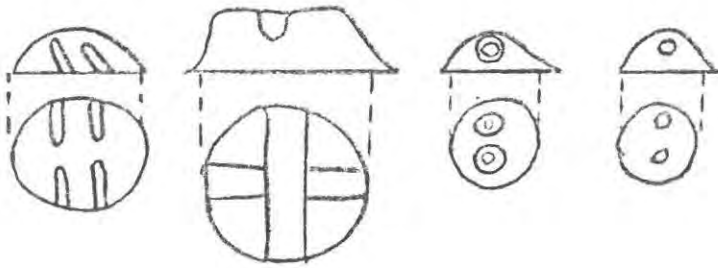

TYPE #11

VIQUES

Fig. 200

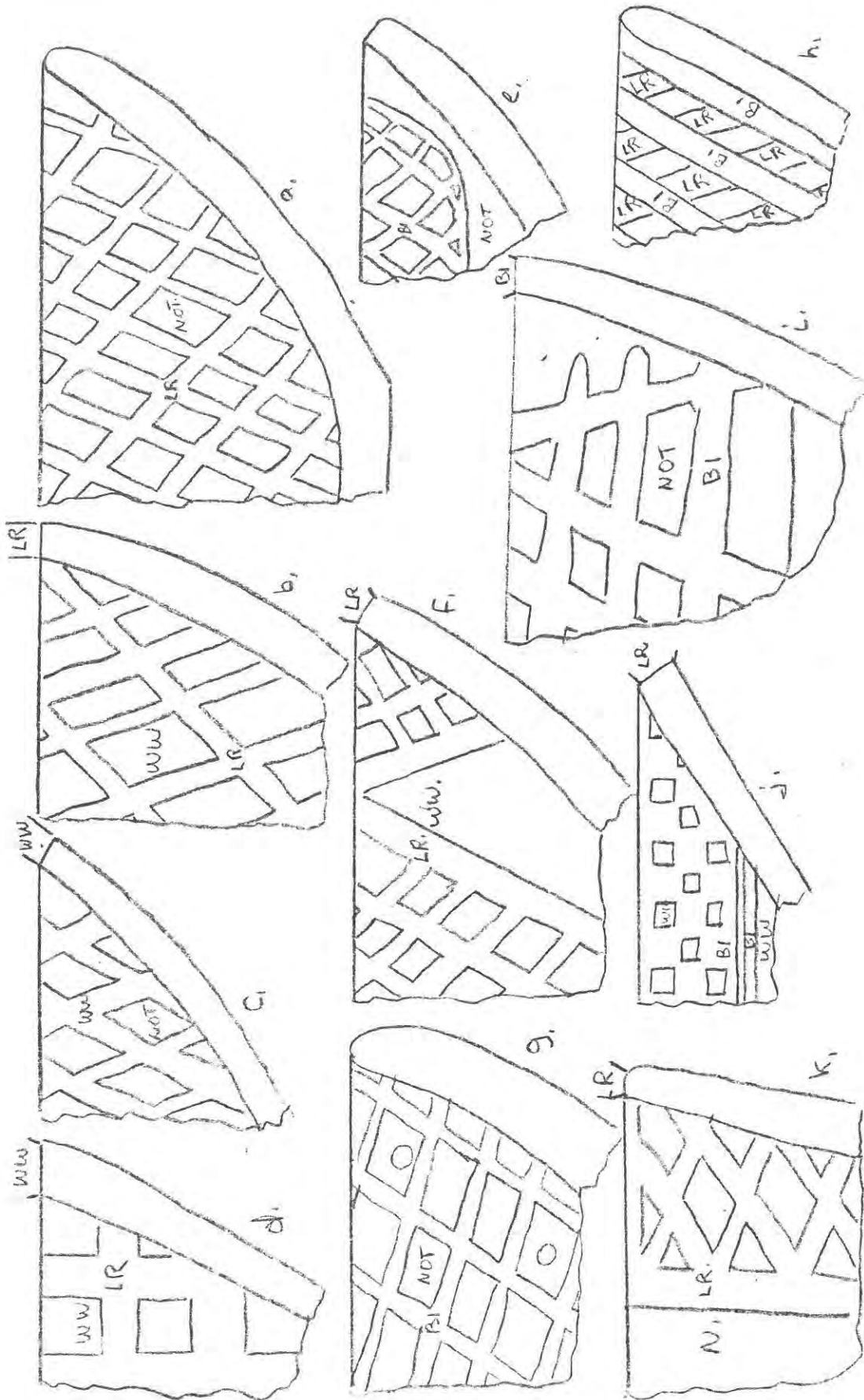

VIQUES

Fig. 201

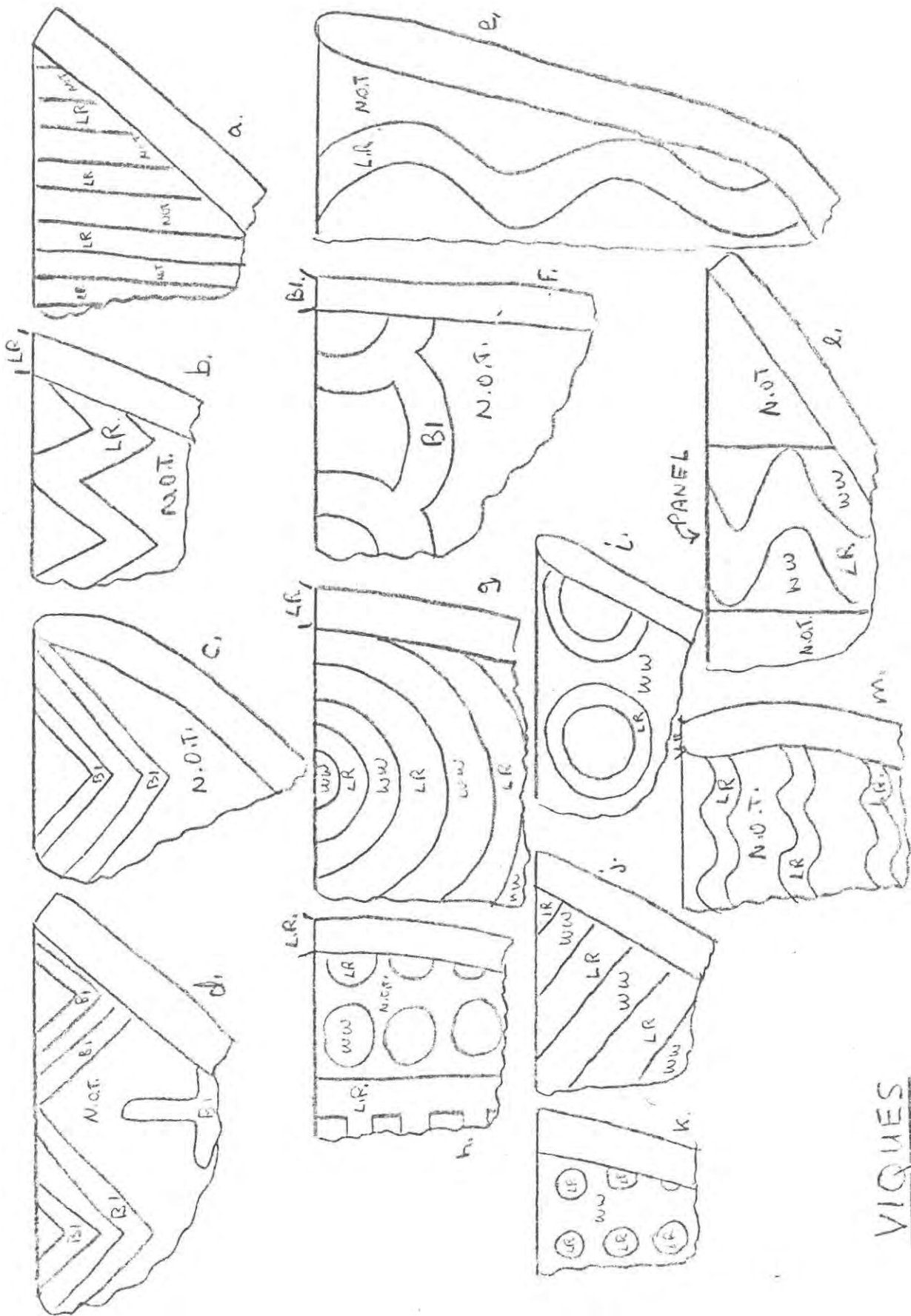

VIQUES

Fig. 202

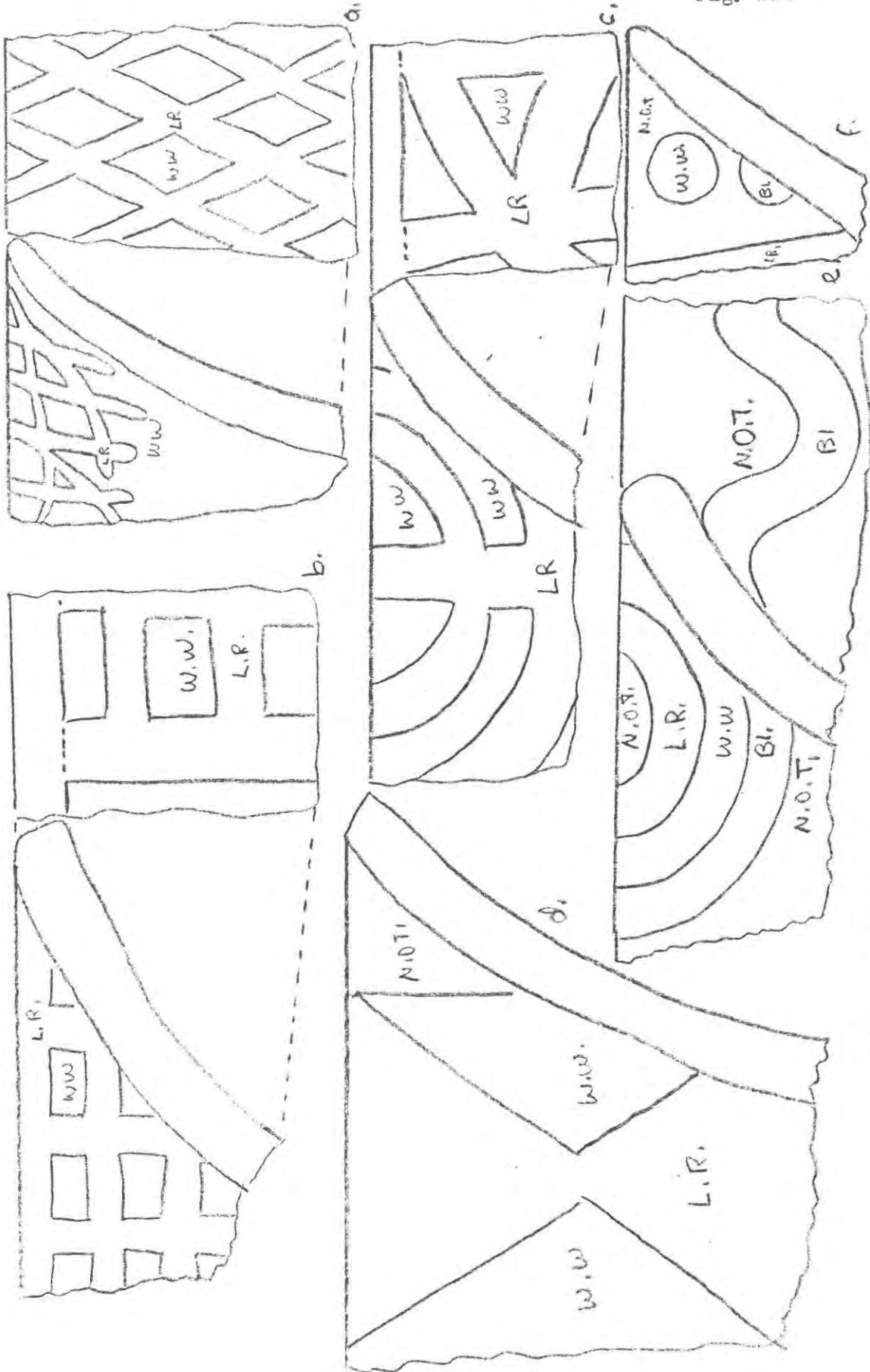

VIQUES

Fig. 203

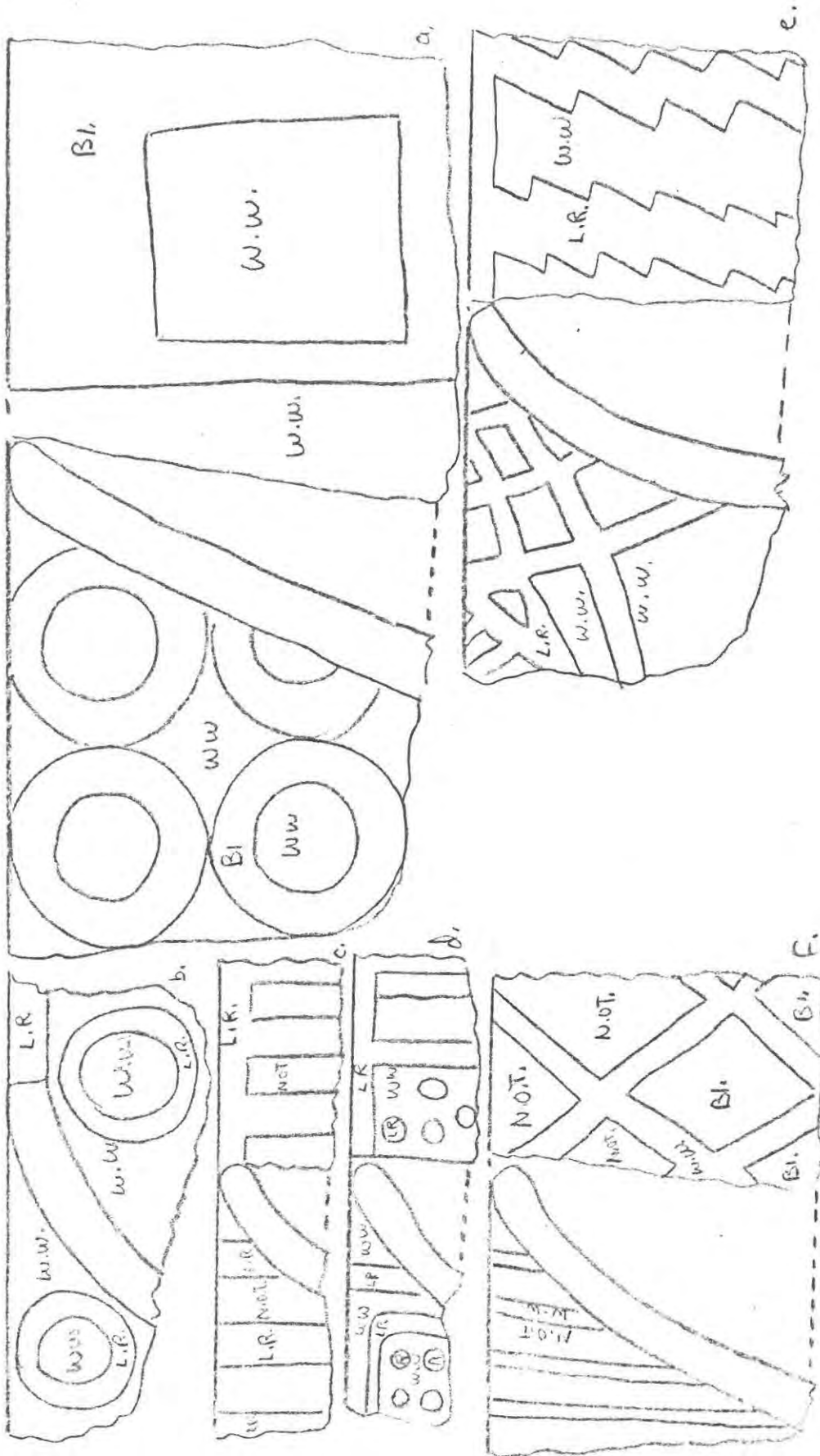

VIQUES

Fig. 204

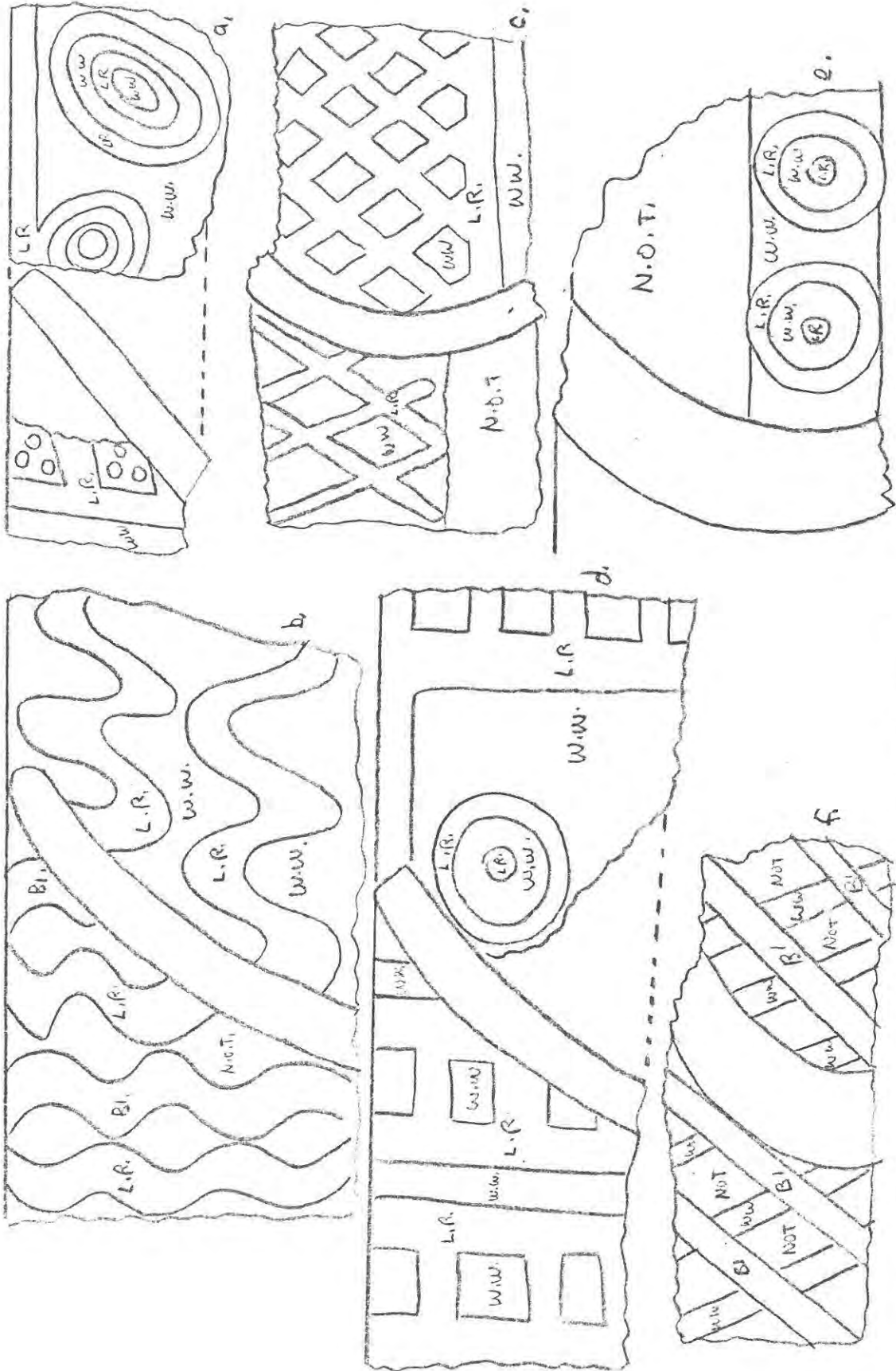

VIQUES

Fig. 205

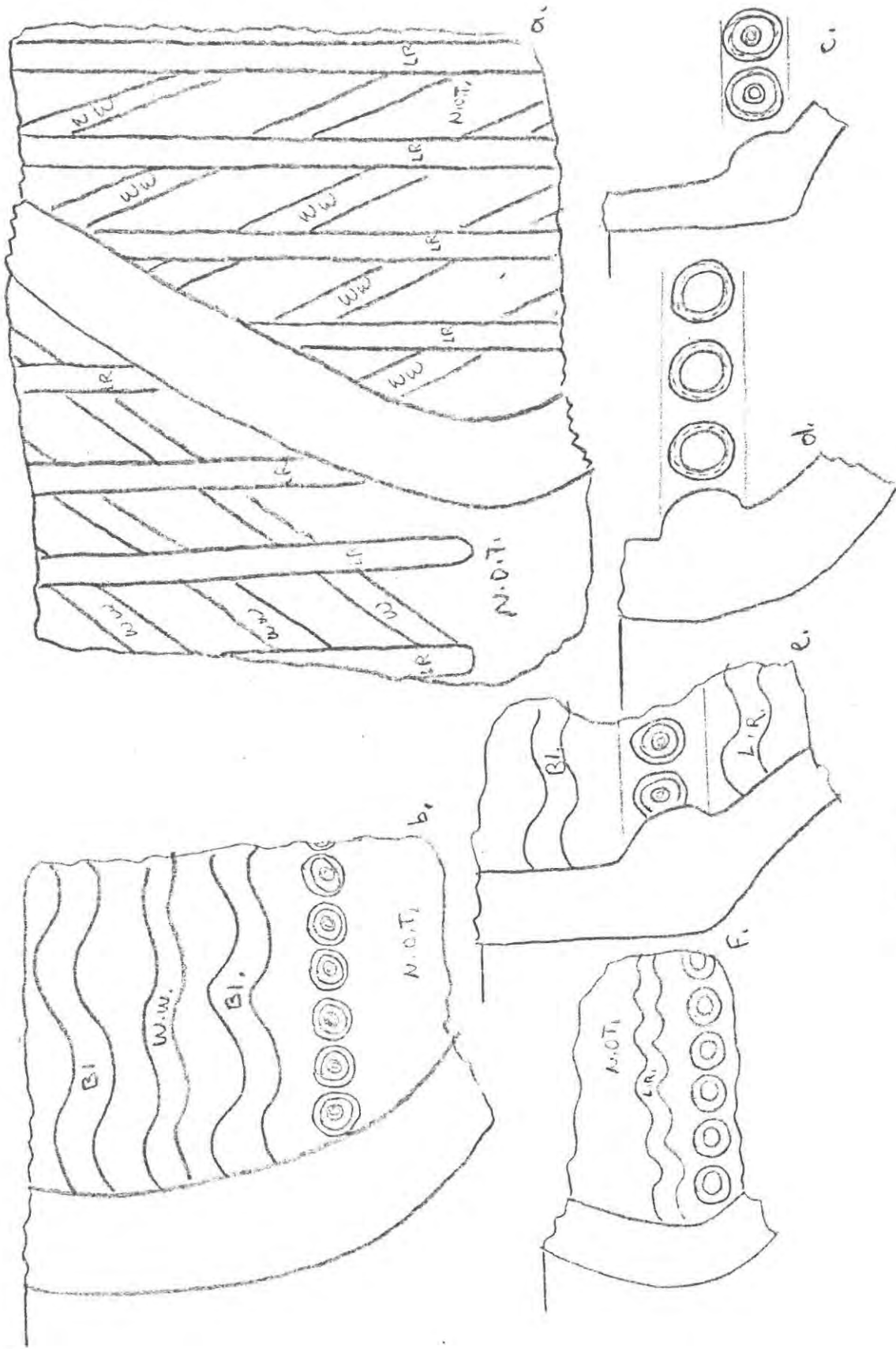

VIQUES

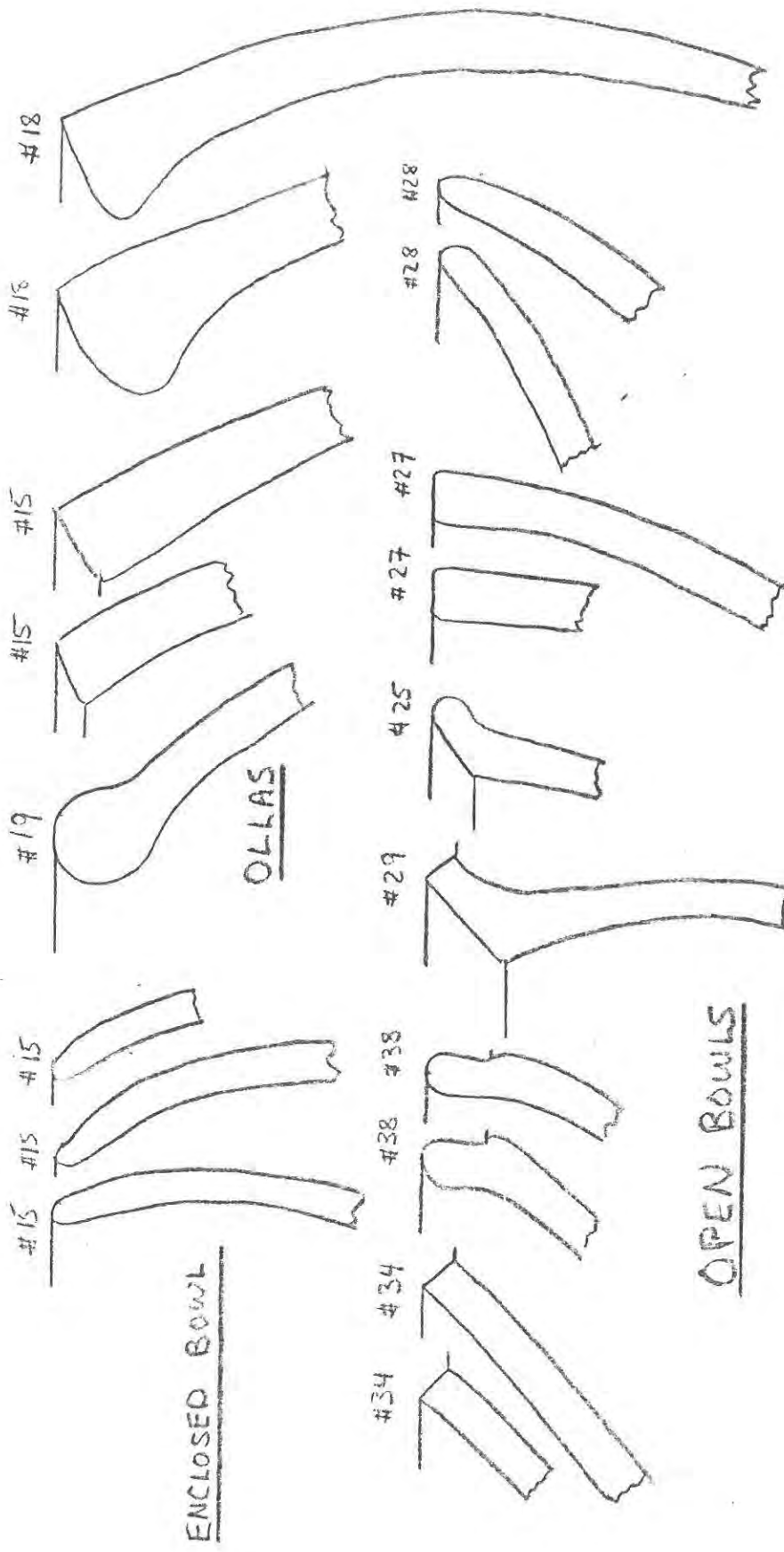

LLAQSA -VARIOUS

Fig. 207

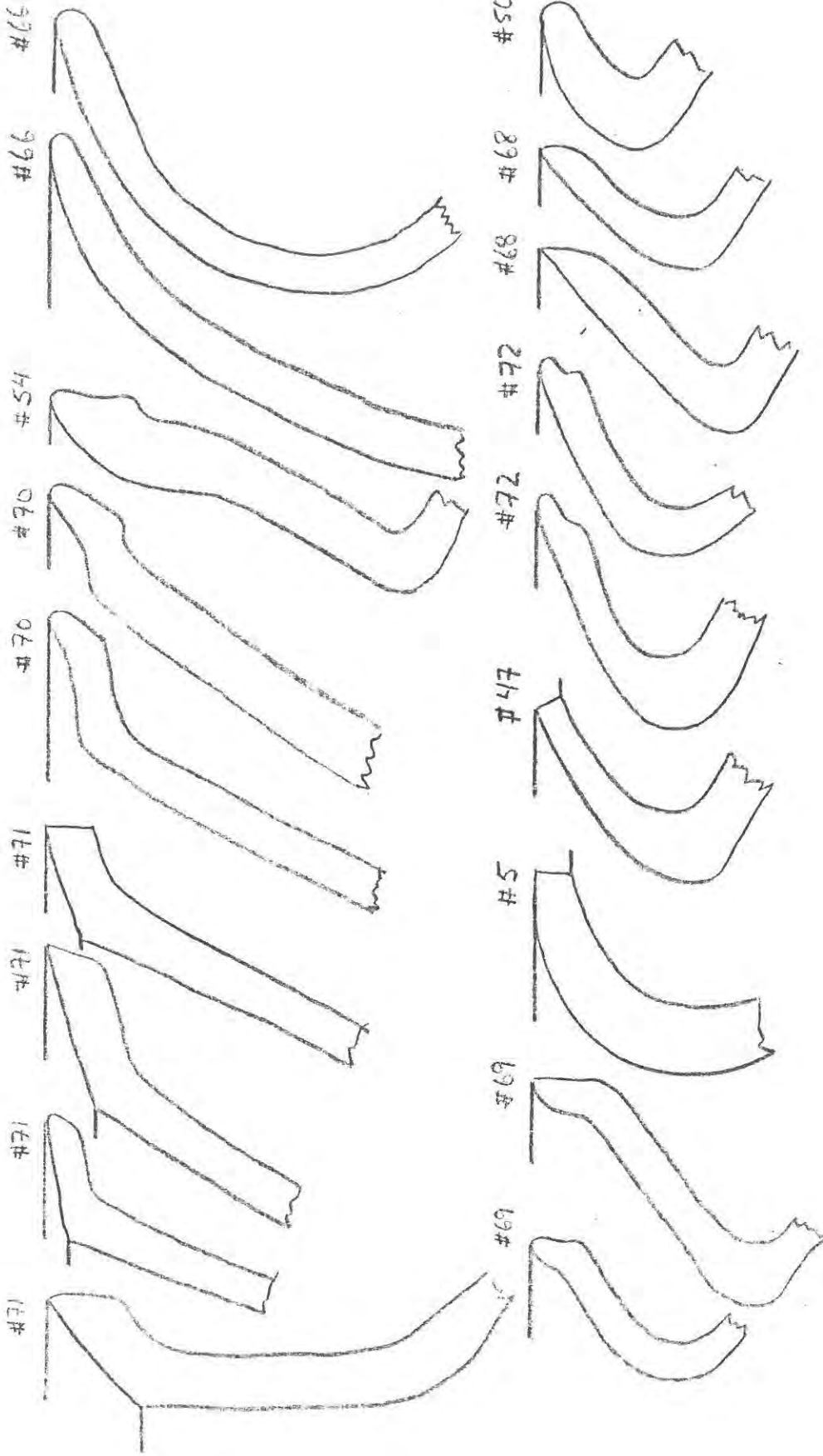

LLAQSA JARS

Fig. 208

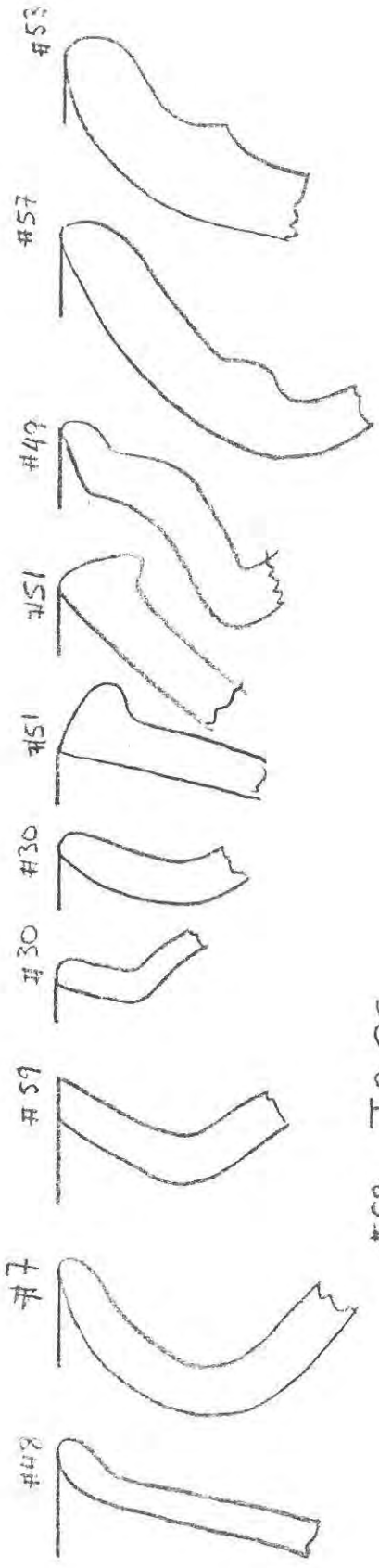

JARS



PEDESTAL BOWL

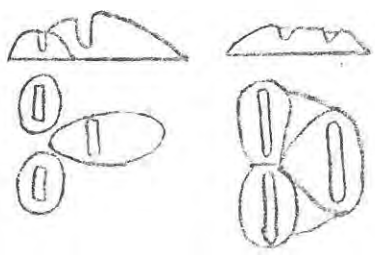
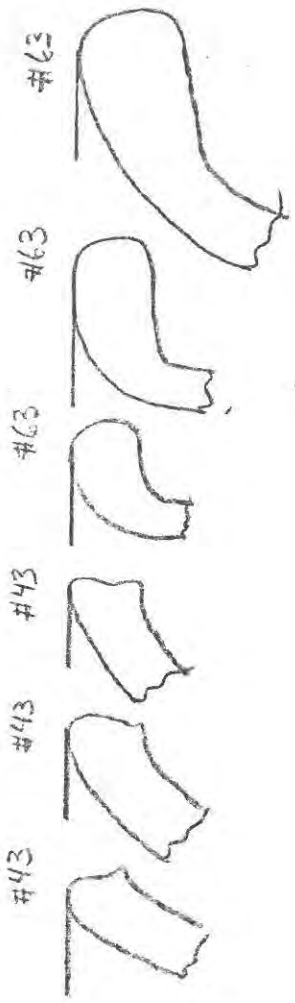

LLAQSA-VARIOUS

Fig. 209

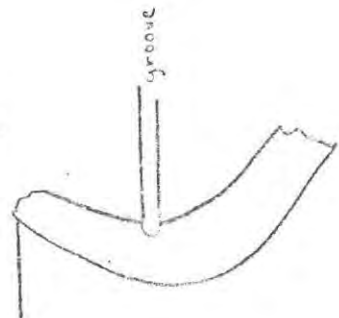
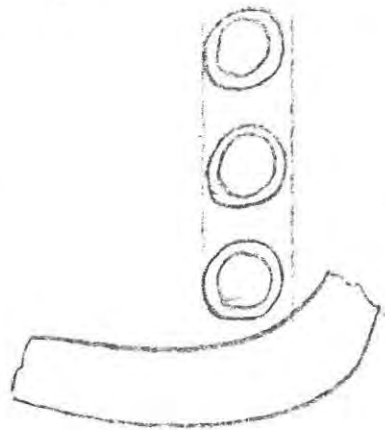
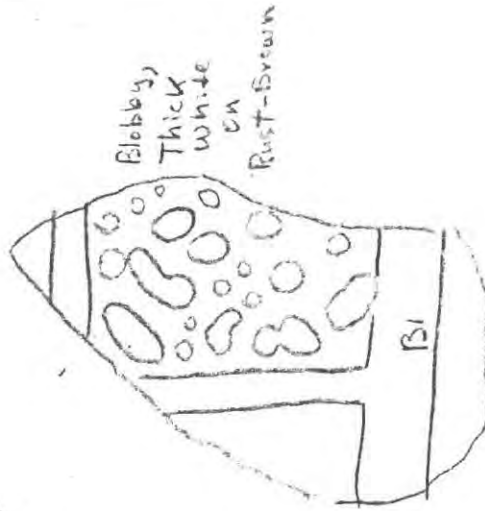
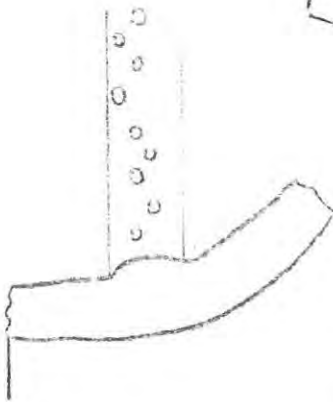
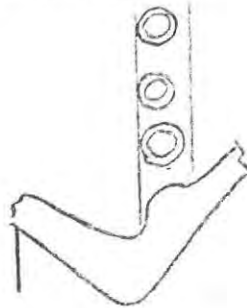
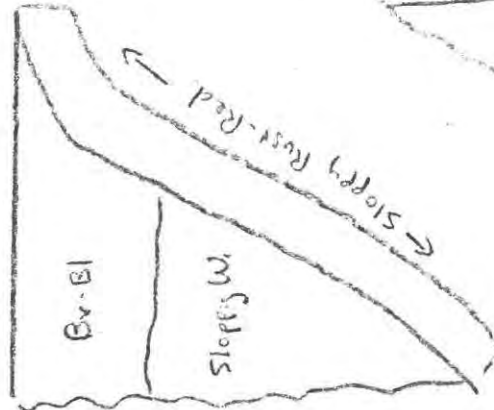
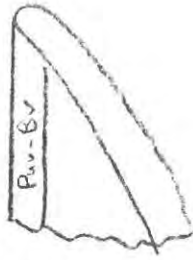
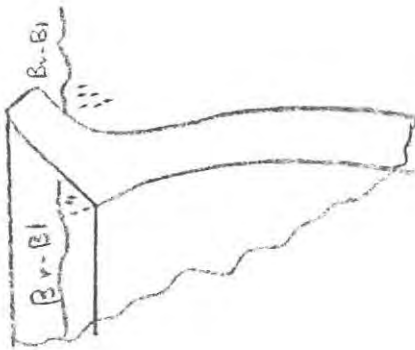
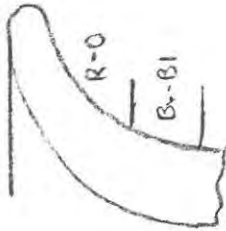
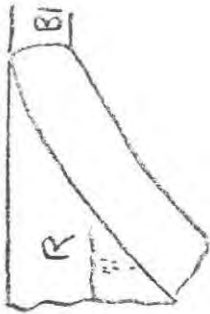
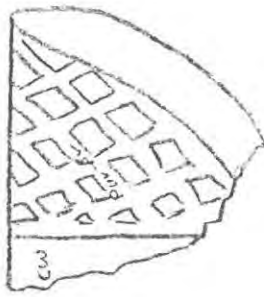

LLAQSA

Fig. 210

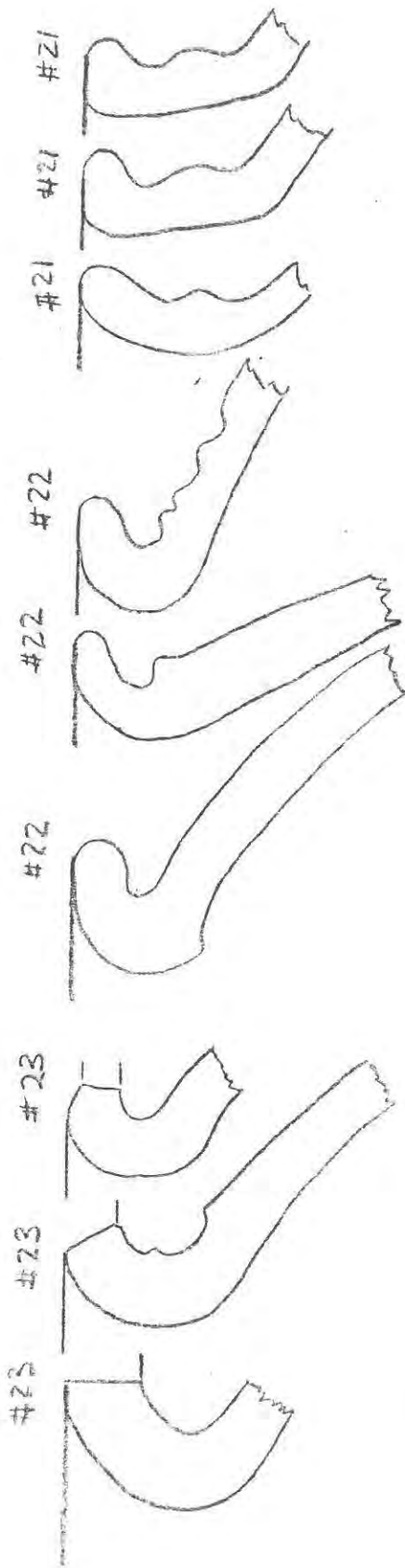
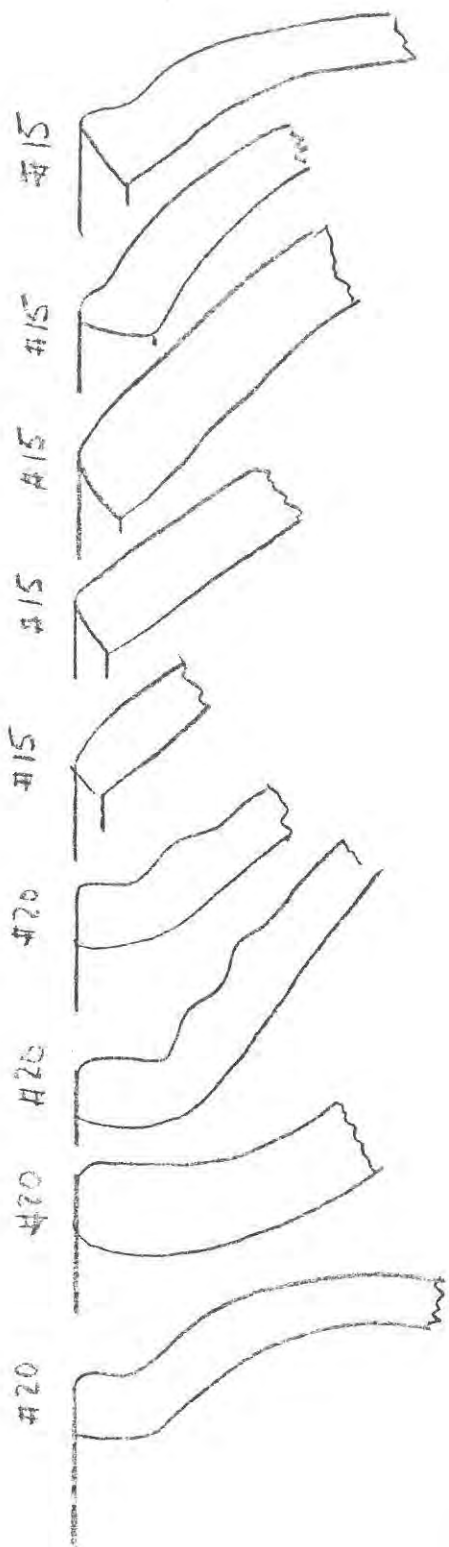

OCOPA - OLLA, LOW-RIMMED OLLAS

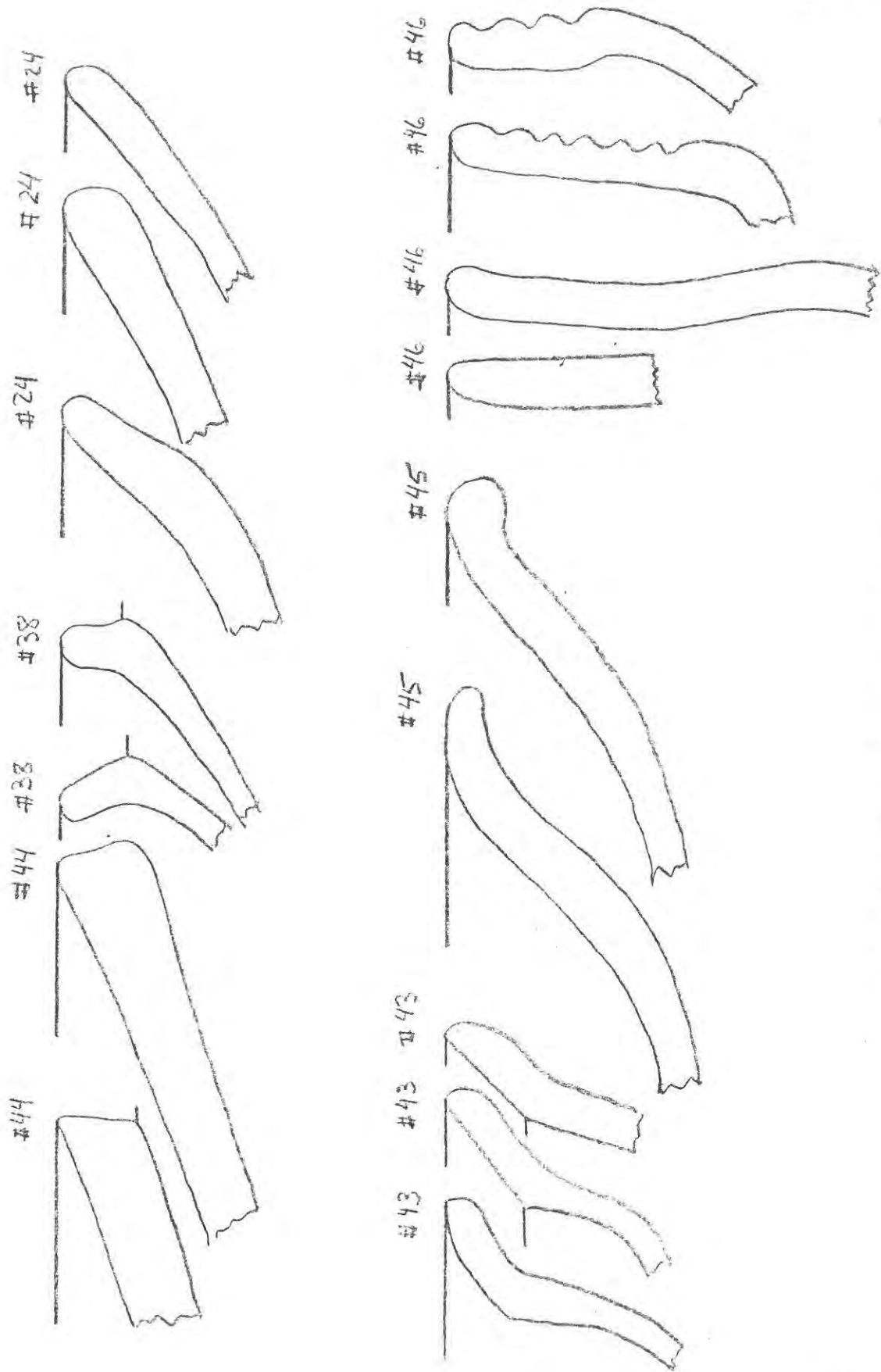

OCO PA OPEN BOWLS

Fig. 212

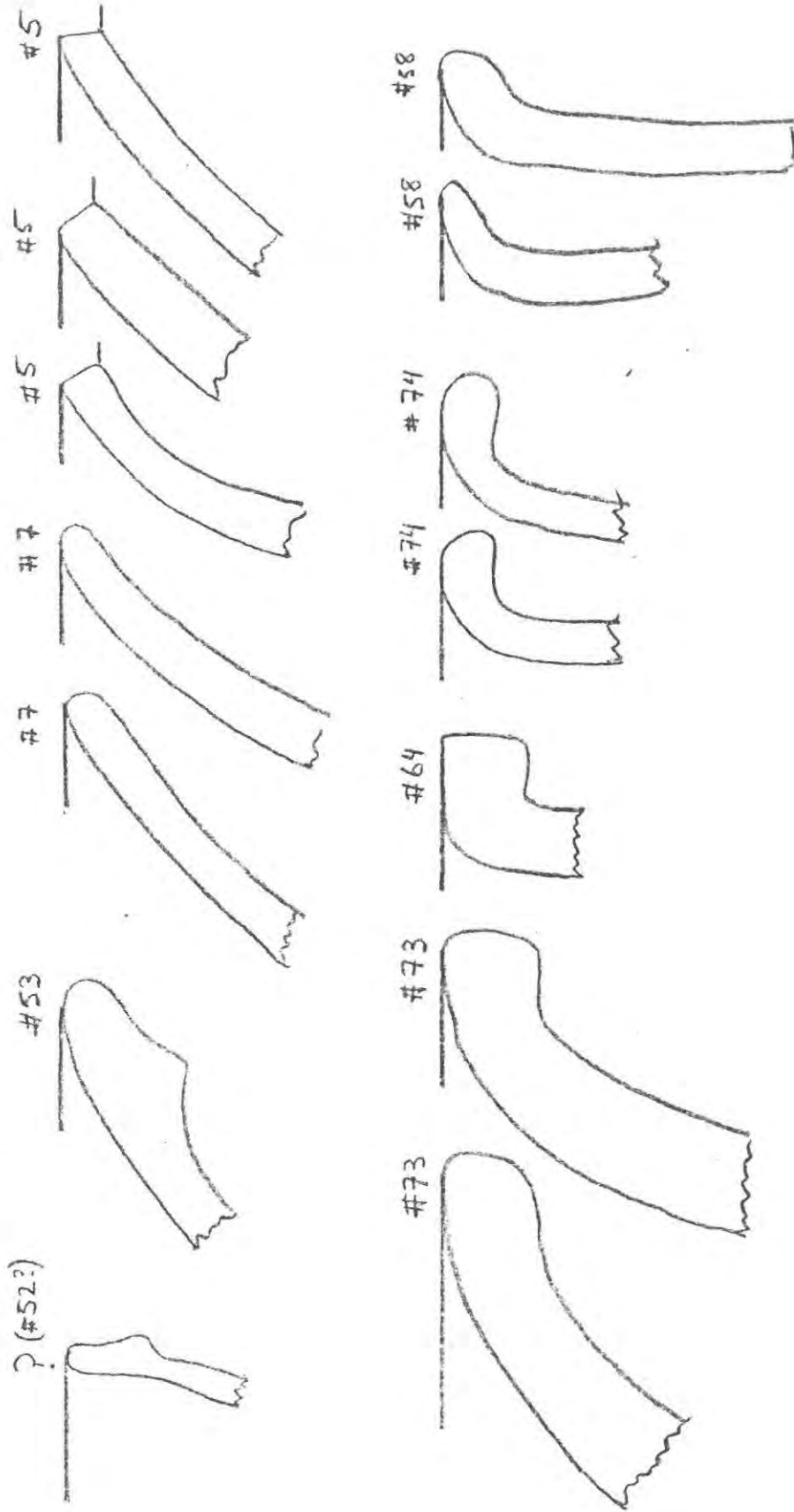

OCOPA - JARS

Fig. 213

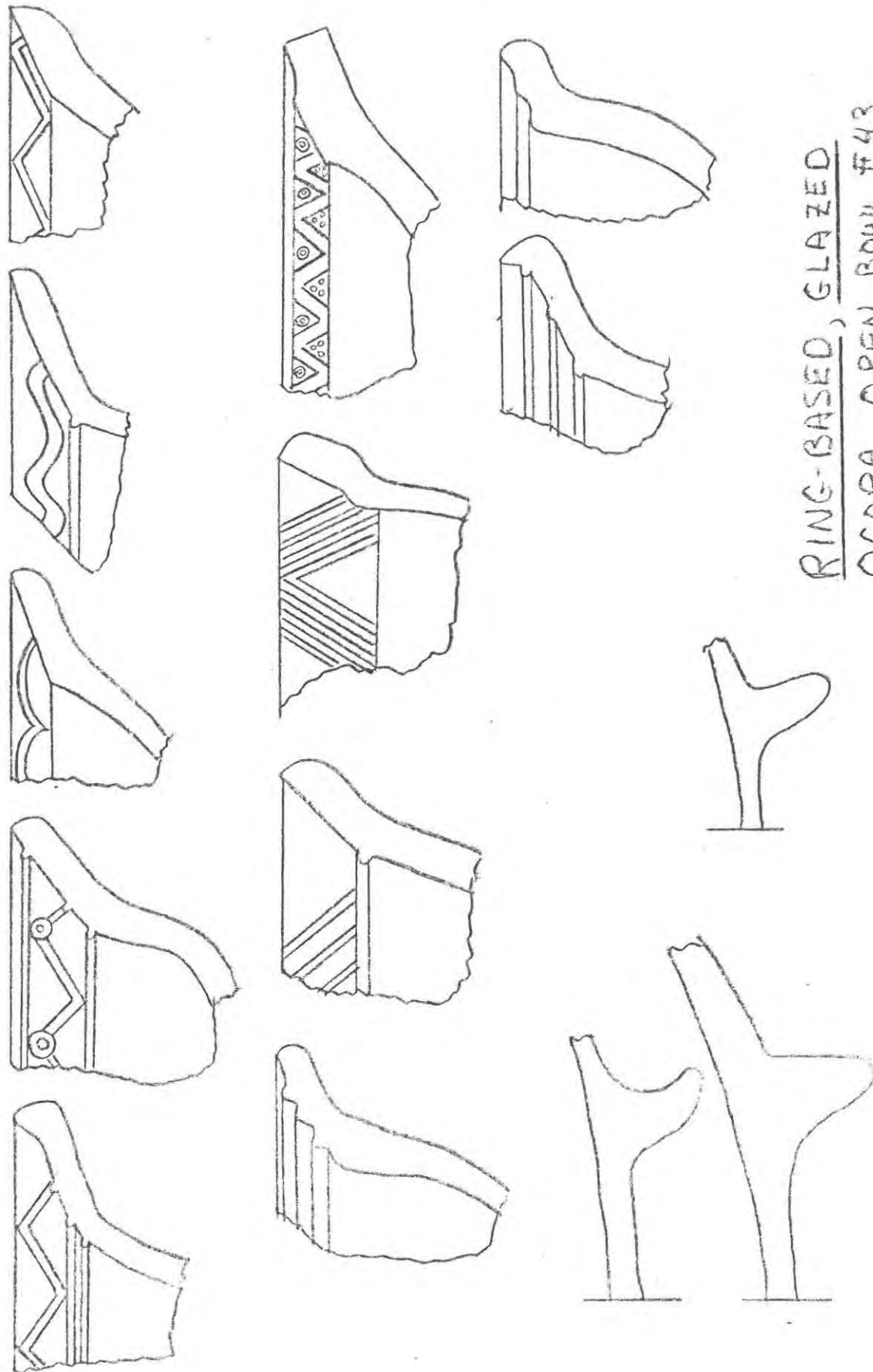

RING-BASED, GLAZED
OCOPA OPEN BOWL #43

Fig. 215

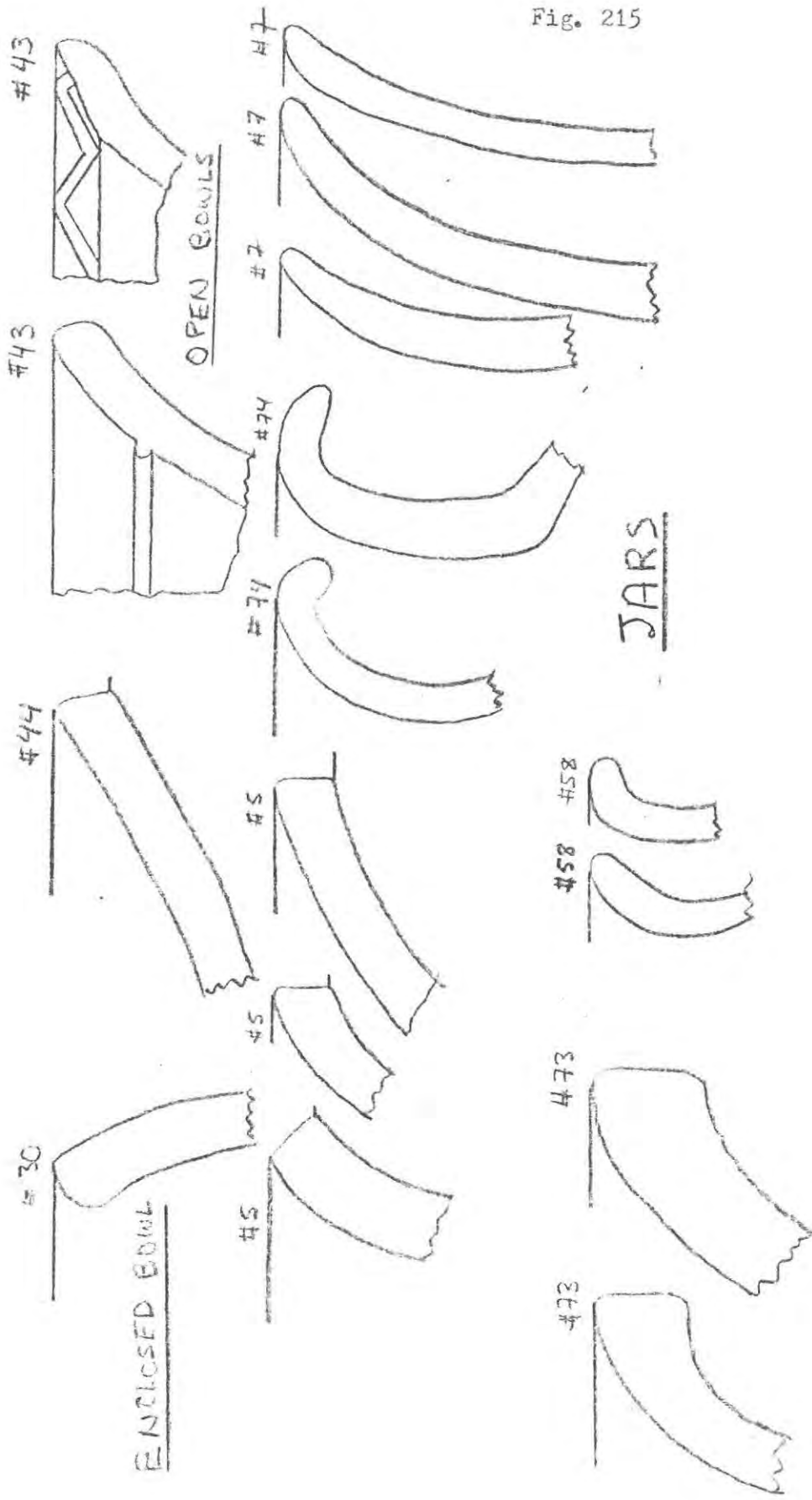

RETAMA - VARIOUS

Fig. 216

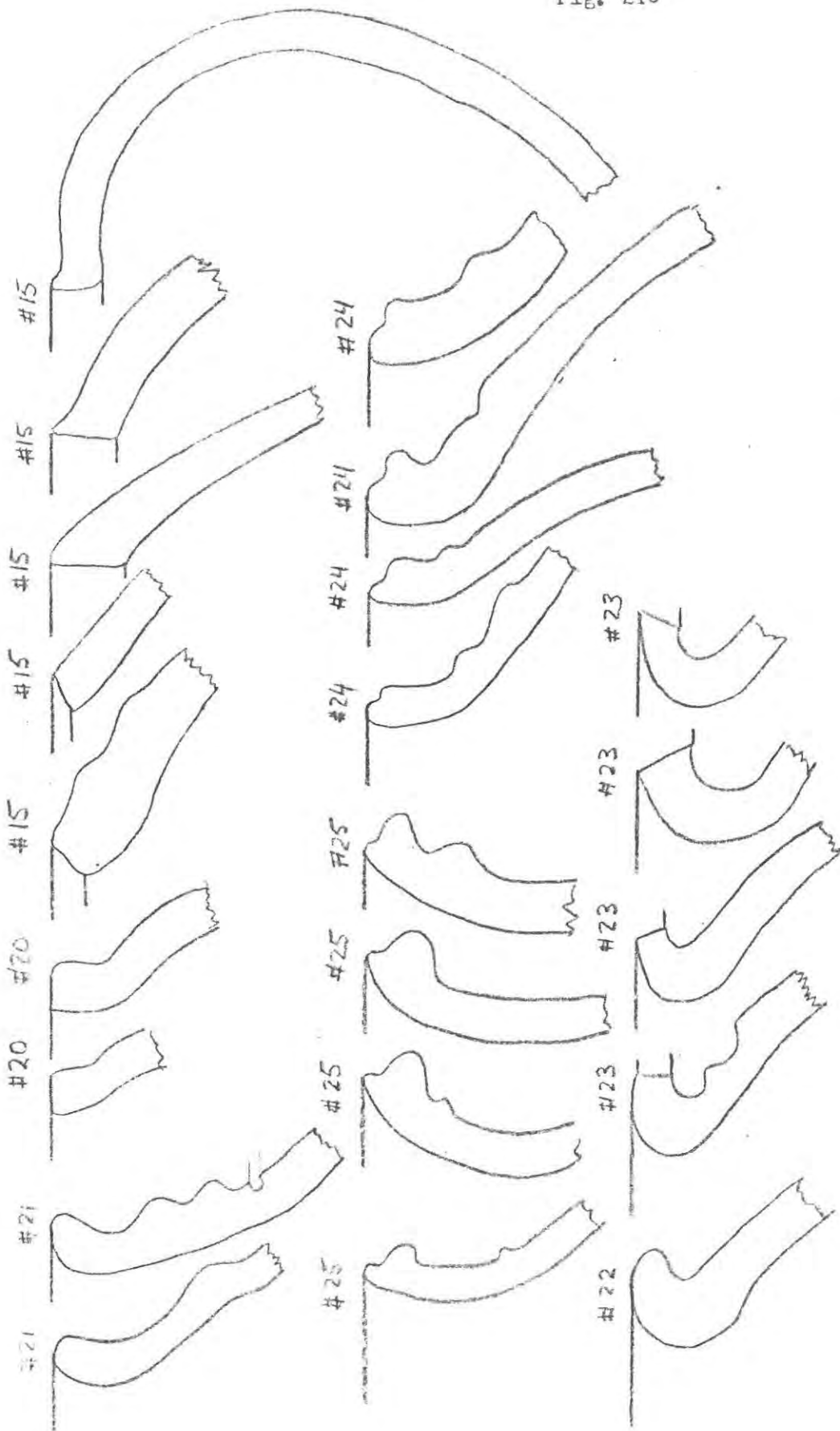

RETAMA - OLLAS

Fig. 217

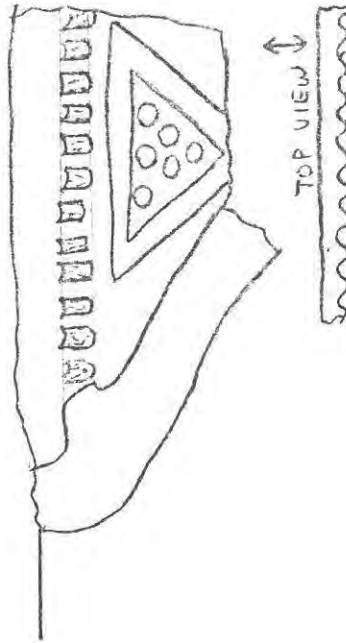
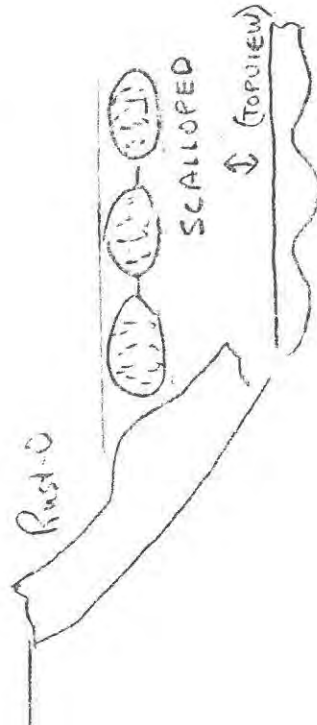
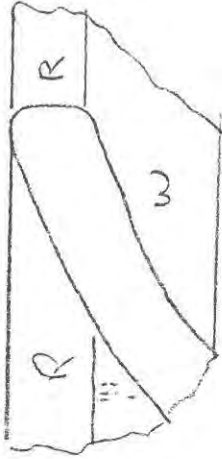
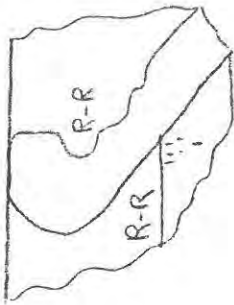

RETAMA

Fig. 218

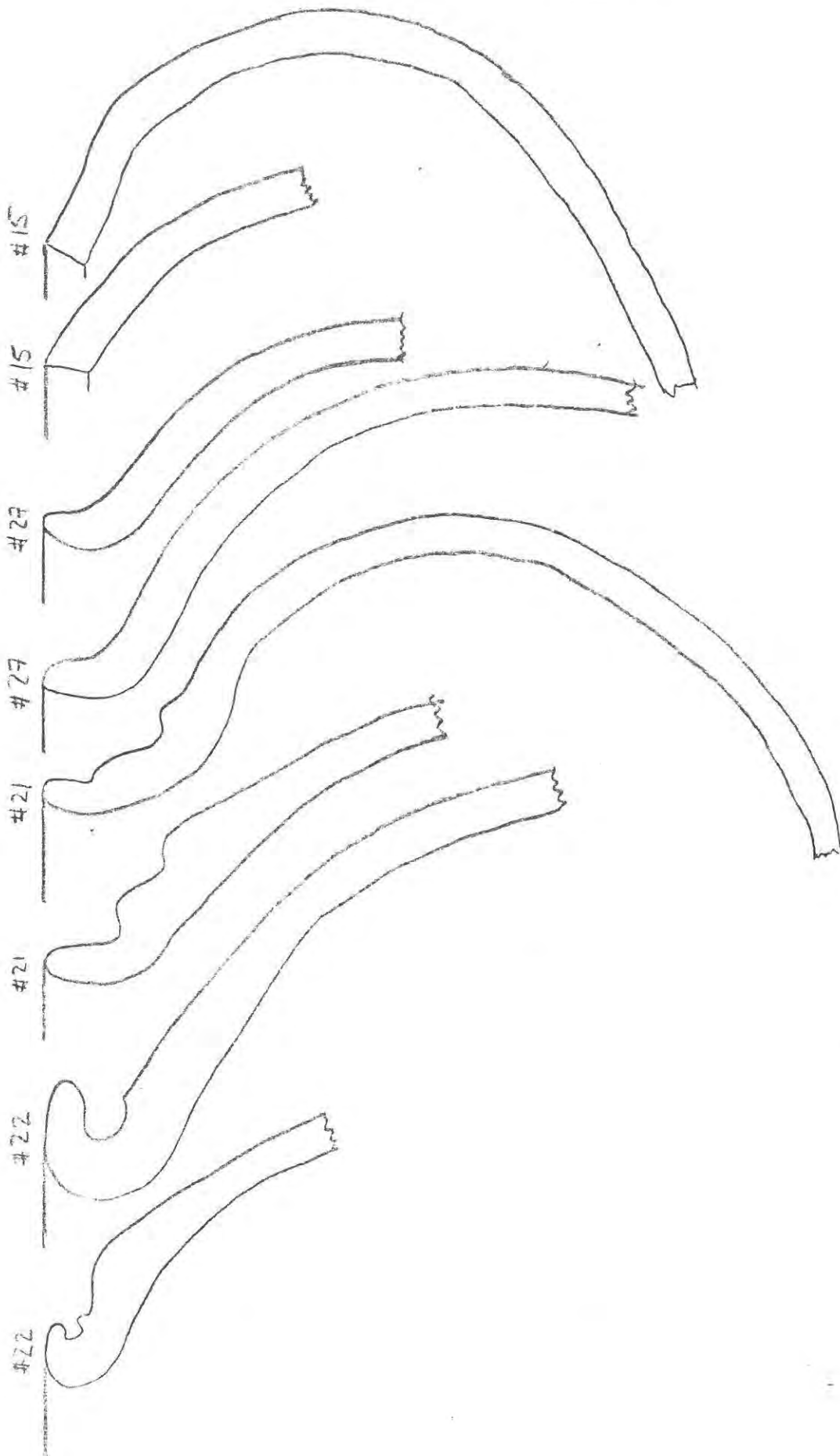

MODERN OLLAS

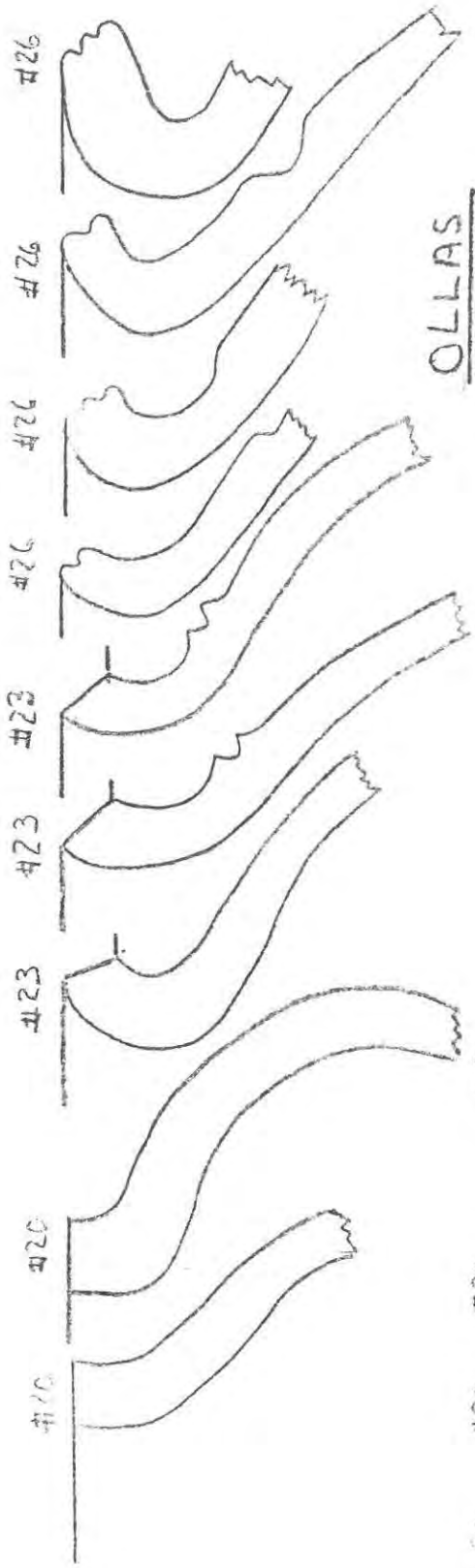

OLLAS

ENCLOSED BOWL
(POPCORN POPPER)

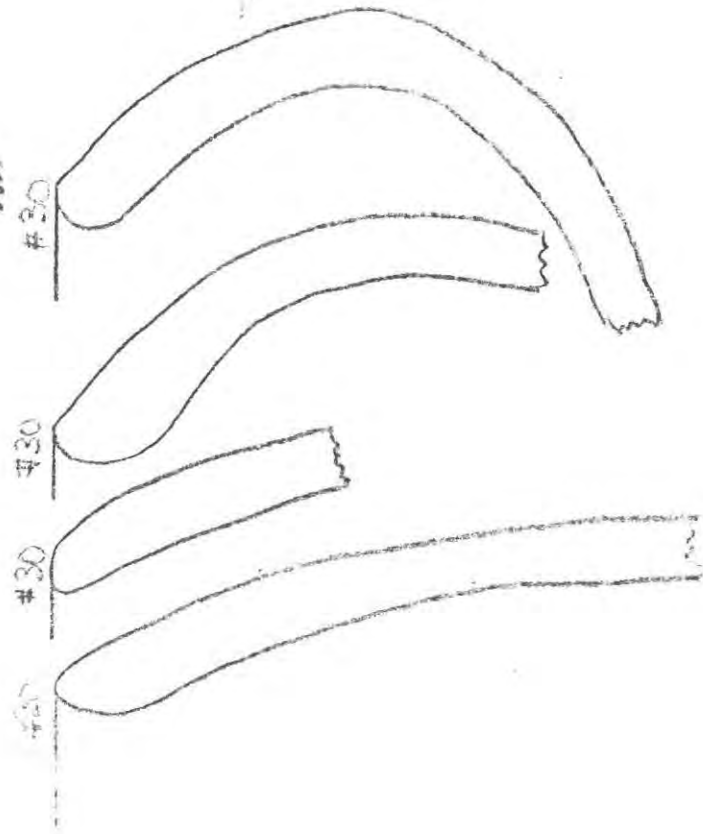

MODERN-VARIOUS

Fig. 220

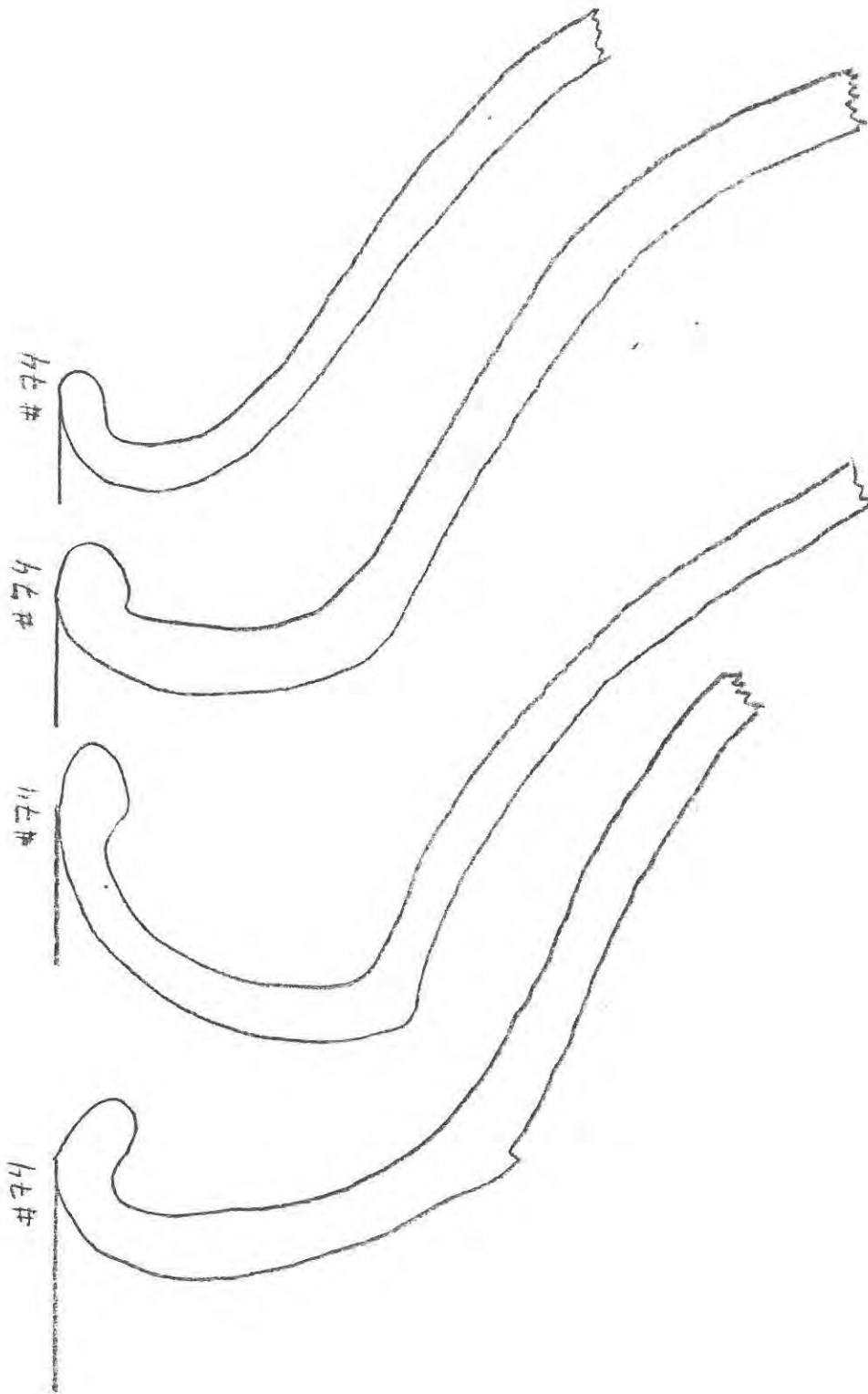

MODERN JARS

Fig. 221

